

Uniclass	EPIC
L3811:P43	C421:X421
CI/SfB	
(21-4)	Xh4



comar
ARCHITECTURAL ALUMINIUM SYSTEMS

comar6EFT

Advanced Curtain Wall Systems

A flexible system, providing a bespoke solution for curtain walling, capped, 2sided and 4sided SG, with options for facets and concealed vents.



complementing architecture

Design

Solution

Perform

Deliver

On-time

Sustainable



comar

Comar Architectural Aluminium Systems is the largest British, privately owned aluminium systems company in Europe.

Comar designs, extrudes and distributes over 700 integrated profiles to a Nationwide approved fabricator network for use in aluminium ground floor treatment, window, door and curtain walling applications.

Comar has built its reputation on delivery; over £3M of mill, standard white polyester powder coating, silver and bronze anodised profiles are kept in stock. This means that 99% of orders are fulfilled by our customers next weekly delivery. Single and dual colour polyester powder coating can be delivered in 15 working days. For architects and specifiers, a Nationwide team of specification consultants provide project-by-project advice on design, building regulations, U-value and wind loading calculations as well as NBS specifications, budget pricing and approved fabricators. This service to specifiers ensures that projects run smoothly from concept to installation.

Comar Architectural Aluminium Systems is an ISO 9002 registered company. Comar is a sponsor member of the CWCT; is a member of the Council for Aluminium in Building (C.A.B), and is a Technical Committee member. Comar provides CPD seminars to architects and designers through the RIBA CPD network and offers CWCT training courses and seminars through its own Training Centre at Mitcham in Surrey.

Membership with these Associations ensures that customers are kept up-to-date with the very latest in building technology and regulations.

Comar Designed for Performance, Backed by Delivery.



design

Aluminium Facades

Designing reassurance from the first stroke of the pencil is often the desire of even the most innovative practice. A proven system that has the potential of providing bespoke solutions exceeding current capability is now a reality.

To provide a flexible approach to aluminium façade engineering Comar Architectural Aluminium Systems launch Comar 6EFT utilising European wide design and extrusion expertise with Comar's market leading supply, support and delivery.

Comar 6EFT delivers curtain walling with 50mm standardised sight-lines with options for: four sided structural silicon glazing, two sided structural silicon glazing with horizontal or vertical capping, concealed vents which maintain the slim 50mm sight-lines, roof glazing which can be pitched, sloped, barrelled or pyramid and faceted glazing options.

Comar 6EFT offers architects a custom made solution with time proven reassurance. Design flexibility is at your finger-tips which offers performance beyond the capability of existing systems.

When tested to the latest CWCT standards at Taywood Engineering Limited, Comar 6EFT achieved air permeability 750 pascals, water tightness 750 pascals static, water tightness 600 pascals dynamic, wind resistance 2400 pascals and 3600 pascals safety.



COMAR6EFT

solution

Facades

Comar 6EFT Curtain Wall

Comar 6EFT Curtain Wall enables the construction of sheer high-rise as well as sloped and inclined facades.

Thermally efficient with standardised 50mm profiles, custom-made profiles are available on request.

Comar 6EFT 4sided SG

Comar 6EFT 4sided structural glazing creates cutting edge facades with no visible aluminium sightlines. Thermally efficient the external discrete sight-line is created with a 20mm EPDM joint seal.

This joint can also be made from silicon sealant.

Comar 6EFT 2sided SG

Design flexibility increases with options for 2sided structural silicon glazing with vertical or horizontal sightlines. A bespoke finish can be achieved through using a variety of cover-caps.

Thermally efficient dependent on the selection of vertical or horizontal lines the structurally glazed side is achieved with a 20mm EPDM joint seal. This joint can also be made with a silicon sealant.

Both vertical and horizontal options use standard 50mm profiles.

Comar 6EFT Facetted

Comar 6EFT Facetted allows the creation of external and internal curves as well as 90° corners.

Facets or segments can be created from 0° with the unique option to create the curve internally or externally.

Drainage

Comar 6EFT is a mullion drained system which meets the requirements of "ventilated and drained glazing system" as specified in BS 6262.

Façade Cover Caps

A variety of cover caps are available for this system. The slimmest sight line can be achieved using a 50mm wide cap, which is double chamfered to provide a visible face of 16mm. Cover caps have a typical edge radius of 1.5mm for even distribution of the powder coating layer.

Windows

Comar 6EFT Concealed Vents

Top or side hung windows integrate directly into the curtain wall.

Concealed vents have no exterior sight-line which means that when closed the façade maintains the same slim sight-lines.

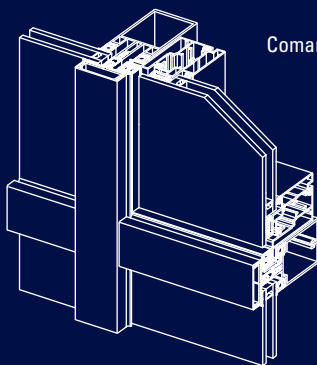

Comar 6EFT Vent

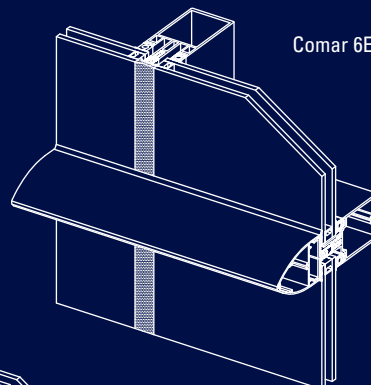

Comar 6EFT 2sided SG

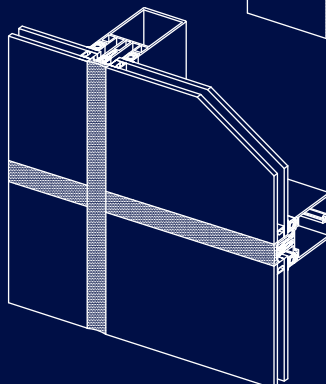

Comar 6EFT 4sided SG

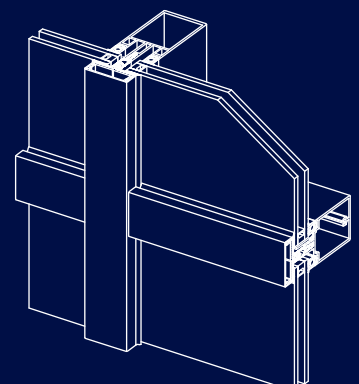

Comar 6EFT Curtain Walling

perform

Specification

Comar Architectural Aluminium Systems have a Nationwide team of architectural advisors who specialise in providing architects and specifiers with project support, calculations and NBS specifications.

The relevant NBS clauses are:

- H11 Curtain Walling
- L10 Windows/Rooflights/Screens
- L20 Doors/Shutters/Hatches

Nationwide Approved Fabricator Network

Once Comar 6EFT has been specified, a Nationwide network of approved fabricators ensures the successful completion of projects. Your Comar architectural advisor can provide fabricators who specialise in commercial, new, refurbishment or public building work.

Calculation

Calculations, such as wind-loading, U-values, size and weight limitations for projects, can be obtained from Comar's Technical Department.

Materials

The system is constructed from extruded aluminium profiles, using alloy 6063 complying with the requirements of BS 1474.

The thermal barrier system is achieved by means of PVC/PP extrusion.

Finishes

Comar 6EFT finishes are available in RAL, Syntha-Pulvin and BS colours. Aluminium profiles are finished to the following specifications: silver, bronze and black anodising AA 25 to BS EN 12373-1: 2001 or BS 3987. Liquid organic coating to BS 4842: 1984. Polyester powder coating to BS 6496: 1984.

Weather Performance

On test at Taywood Engineering Limited, EFT achieved the following:

	Curtain Wall	EFT Vent
Air Permeability	EN 12152 – class AE 750	EN 12207 – Class 4
Water Tightness	EN 12154 – Class RE 750	EN 12208 – Class E 750
Wind Resistance	EN 13116 2400 Pa design, 3600 Pa safety	EN 13116 2400 Pa design, 3600 Pa safety

Thermal Performance

Class 2.1 in accordance with DIN 4108 (2.0-2.8W/m² K) or EN ISO 10077-1.

The thermal transmission (Uf) W/m² K, is dependent on the insulator strip, calculated as per EN ISO 10077-1.

Comparable with class 2.1 DIN 4108 Table 3.

Sound Insulation

Depending largely upon the glass specification, generally the curtain wall framing reduces the figure by 2Db (A).

perform

Gaskets & Glazing

Generally, all glazing shall comply with the requirements of BS 6262: 1982, British Standard Code of Practice for Glazing in Buildings, in terms of wind resistance, safety and security.

This system is glazed from the outside and secured with pressure plates.

The inner seal glazing is the most important seal to avoid air and water entering the building. The system is designed to allow small amounts of water to enter. However, the water must drain out. Special components, known as drainage diverters, are designed to drain the water out of the system. Sufficient drainage slots and pressure equalisation slots must be provided into the pressure plates, pressure-plate gaskets and cover caps. These are dependent on size and configuration. Please refer to Comar's Technical Department for project-by-project advice.

2sided or 4sided SG

The system is glazed from the outside using toggle panes with an EPDM or silicon seal.

Gaskets

Glazing vision strips are made of EPDM conforming to BS 4255 Part 1. Gaskets have injection moulded corner mouldings to ensure a precise and accurate installation of the gasket. Depending on the size of panel or glass to be installed, Comar 6EFT has a wide variety of gaskets which ensure a water-tight fit.

System Limitations

The size limitation of the system depends mainly on the hardware used. For further information, please discuss on a project-by-project basis with Comar's Technical Department.

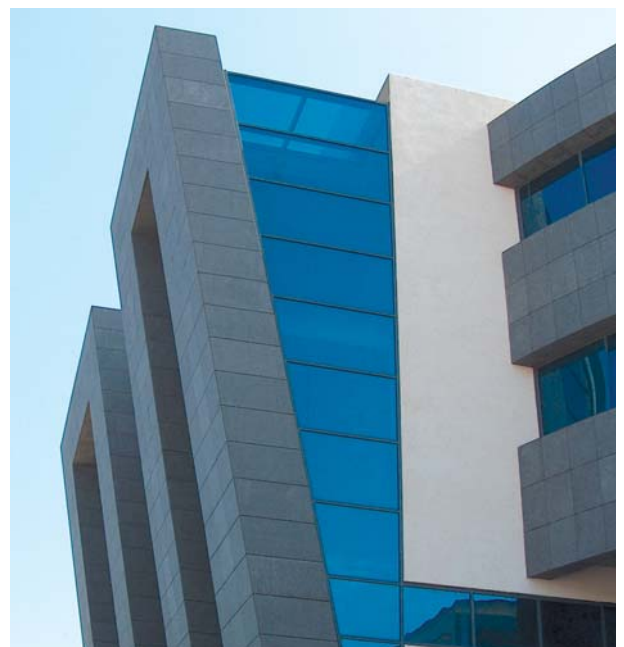

deliver

Construction Comar 6EFT Curtain Walling

Ladder Frame

Ladder frame is assembled in the factory and transported to site in modules or ladder frames. Step cut transoms are fixed to mullions, with optional brackets, with self-tapping screws. Punch tooling and jigs are available to create the necessary fixing holes on the mullion and transom.

Expansion mullions (split-mullions) are also available for expansion purposes or to offer a semi-unitised system reducing installation time.

Stick Build

Is regarded as fast track installation on site and in the factory. Requires punch tooling. Transoms are stepped. If a spring loaded cleat is required, an extra fixing hole is created on the mullion. Preps such as this are created in the factory. The curtain wall is assembled on site, usually from the centre out, mullion first then transoms are front loaded to form the curtain wall. The pressure on a step cut curtain wall is the same on the inside as the outside, known as pressure equalised. Water therefore drains freely and is a true mullion drained system.

Drainage & Ventilation

Mullion drained, by means of a mullion drainage diverter, minimum one above each mullion-coupling and through slots in vertical pressure plate and gasket of 30x15mm. Cill sections with optional flashing to front transom ensures the water does not penetrate at floor level.

Installation of Curtain Wall

Glazing supports are clipped into transoms at 100mm from the end, then glazed. Gaskets and spacers are then added with the pressure plate which is screwed in place with a torque wrench at 200/250 centres, 25mm from the top. Face caps, in a variety of shapes, are clipped on the mullion and transoms to create the finished curtain wall.

Propped or Hung Conditions

Fixing Comar 6EFT has two options the propped or hung condition. In the propped condition, Comar 6EFT is fixed from floor level and, in the hung condition, fixing occurs at the top of the building and is hung down the façade.

Facetted Options

A full range of glazing adaptors and pressure plates are available to meet most corners for both internal and external corners.

Visible sight lines can be kept to a minimum by painting the pressure plates in a dark colour.

Comar 6EFT 2sided & 4sided sided SG

The installation and construction, along with the drainage and ventilation, are similar to the Comar 6EFT capped system.

Drainage & Ventilation

Mullion drained, by means of a mullion drainage diverter, minimum one above each mullion coupling and through slots in the horizontal or vertical pressure plate and gasket of 30x15mm.

Glazing

Glass and spandrel panels are installed and fixed by means of aluminium clamps into pre-fixed inserts into the glass cavity.

Joints between glass and/or spandrel panels are closed by means of silicone sealant or by EPDM or silicone profiles.

(All combinations of glass, joint seals and/or bonding have to be in accordance with regulations as set by glass, glue and sealant suppliers).

Comar 6EFT Vents

Comar 6EFT Vents are thermally broken by means of Pi thermal break strips. Vents are available for standard capped as well as for Comar 6EFT 2 or 4 sided curtain wall.

The vents are top-hung open out and hinged by means of friction hinges.

Installation of Vents into Comar 6EFT Capped

Vents are glazed into the back structure and are secured by a minimum of one self tapping screw at both sides into the mullion and also by pressure plates and caps.

Installation of Vents into Comar 6EFT 2 or 4 sided

Vents are glazed into the back structure and are secured by a minimum of one self tapping screw at both sides into the mullion and also by clamps with self tapping screws.

Drainage & Ventilation

Vents are drained and ventilated through the outer frame of the vent.

Instructions for drainage and ventilation (pressure equalization) options are available.

on-time

Comar 6EFT Curtain Walling.

General arrangement showing Curtain Walling with feature cover cap.

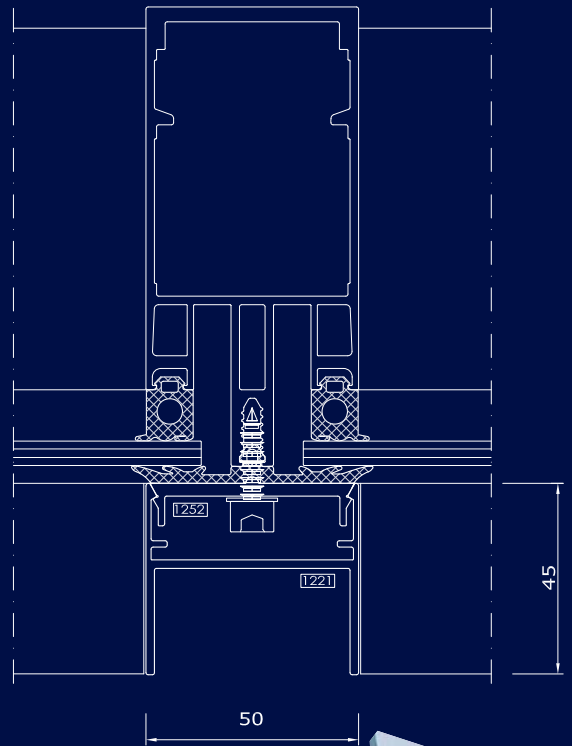
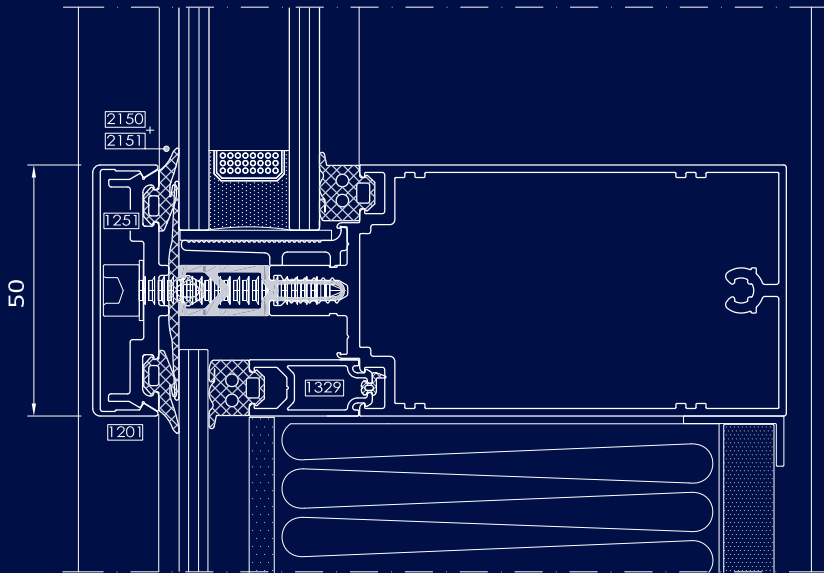

on-time

Comar 6EFT Curtain Walling with Concealed Vent.

General arrangement showing Curtain Walling with concealed vent.

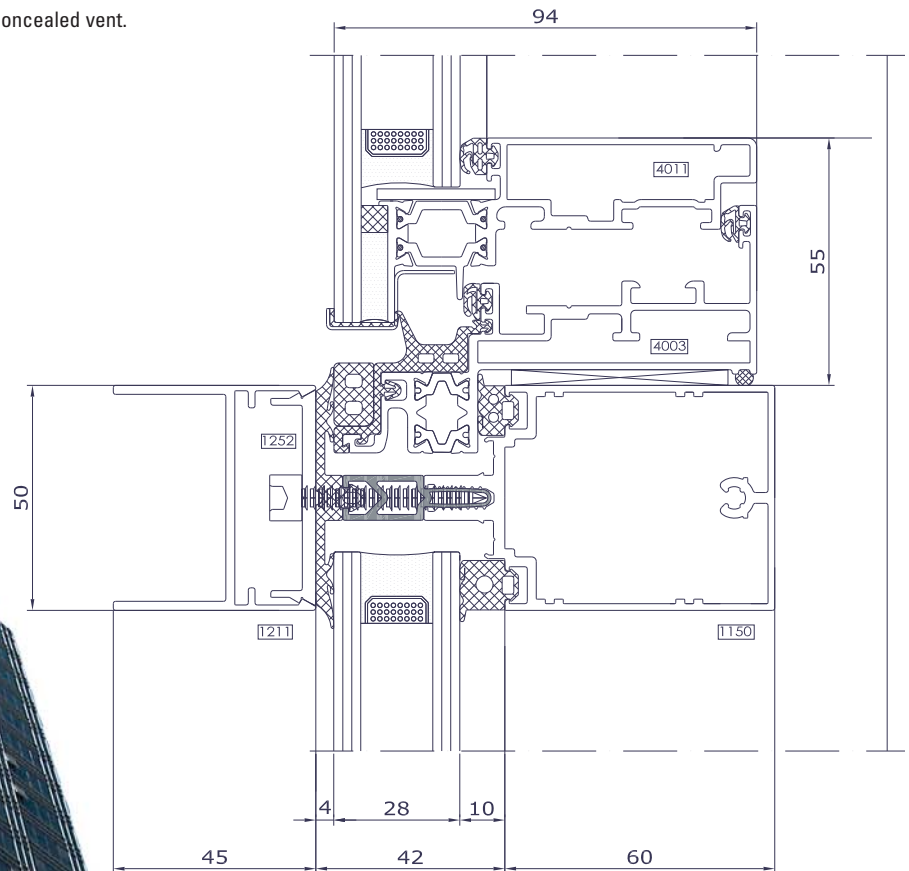

on-time

Comar 6EFT 2sided with Concealed Vent.

General arrangement showing 2sided SG with horizontal capping and concealed vent.

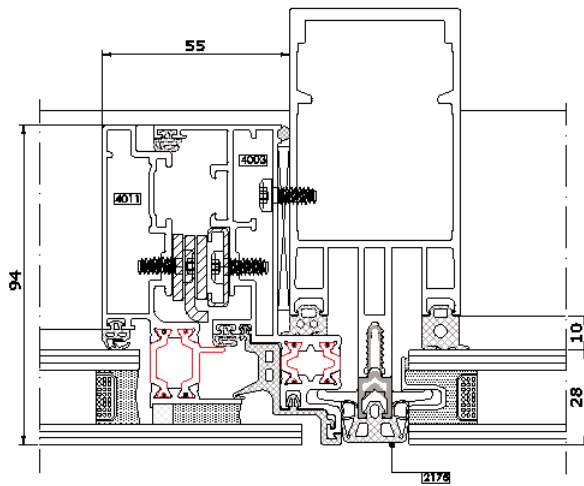

Silicone seal
also available
using gasket
2170

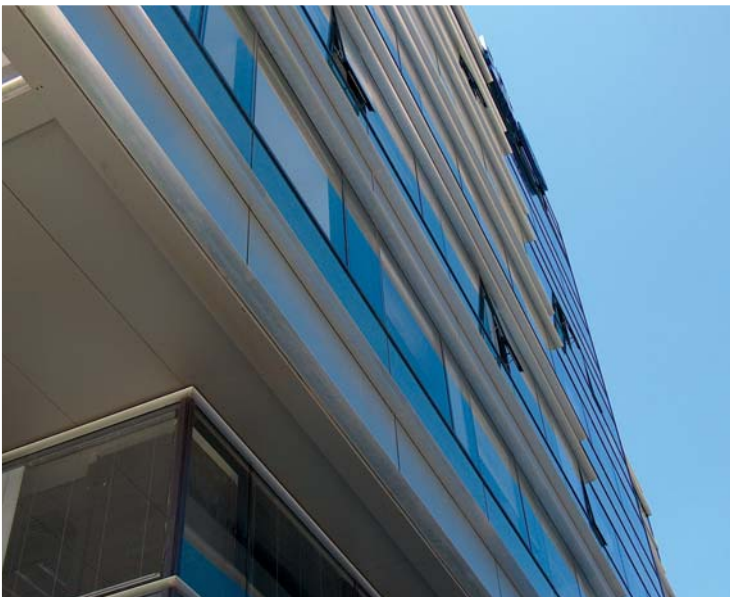
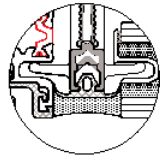

on-time

Comar 6EFT 4sided SG.

General arrangement showing Comar 6EFT 4sided SG with toggle glazing and EPDM seals or silicon seal.

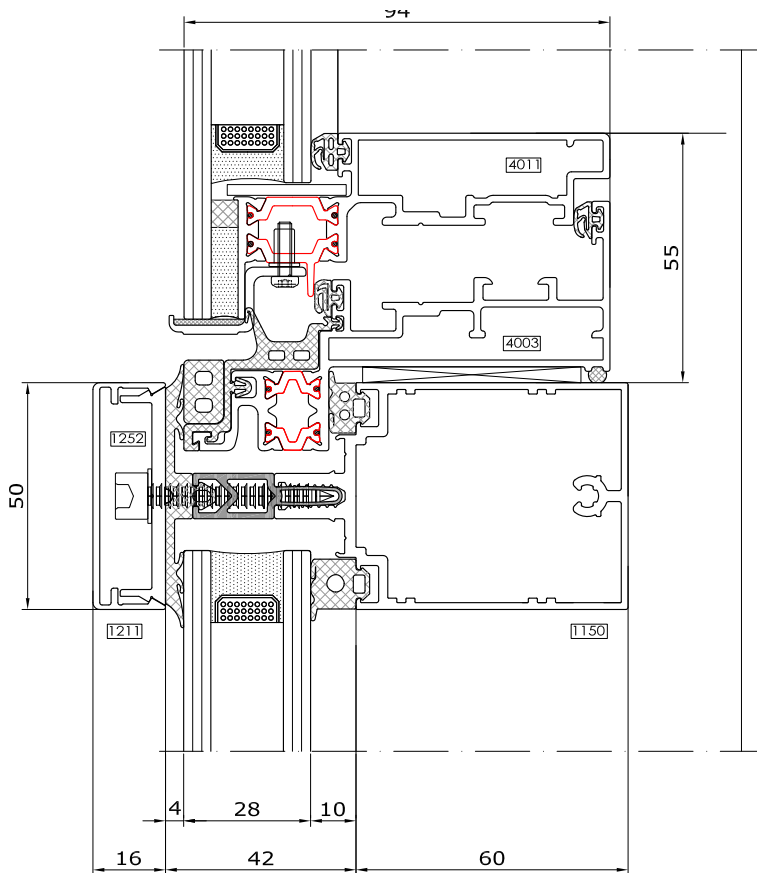

on-time

Comar 6EFT 2sided SG.

General arrangement showing Comar 6EFT 2sided SG with toggle glazing and EPDM seals.

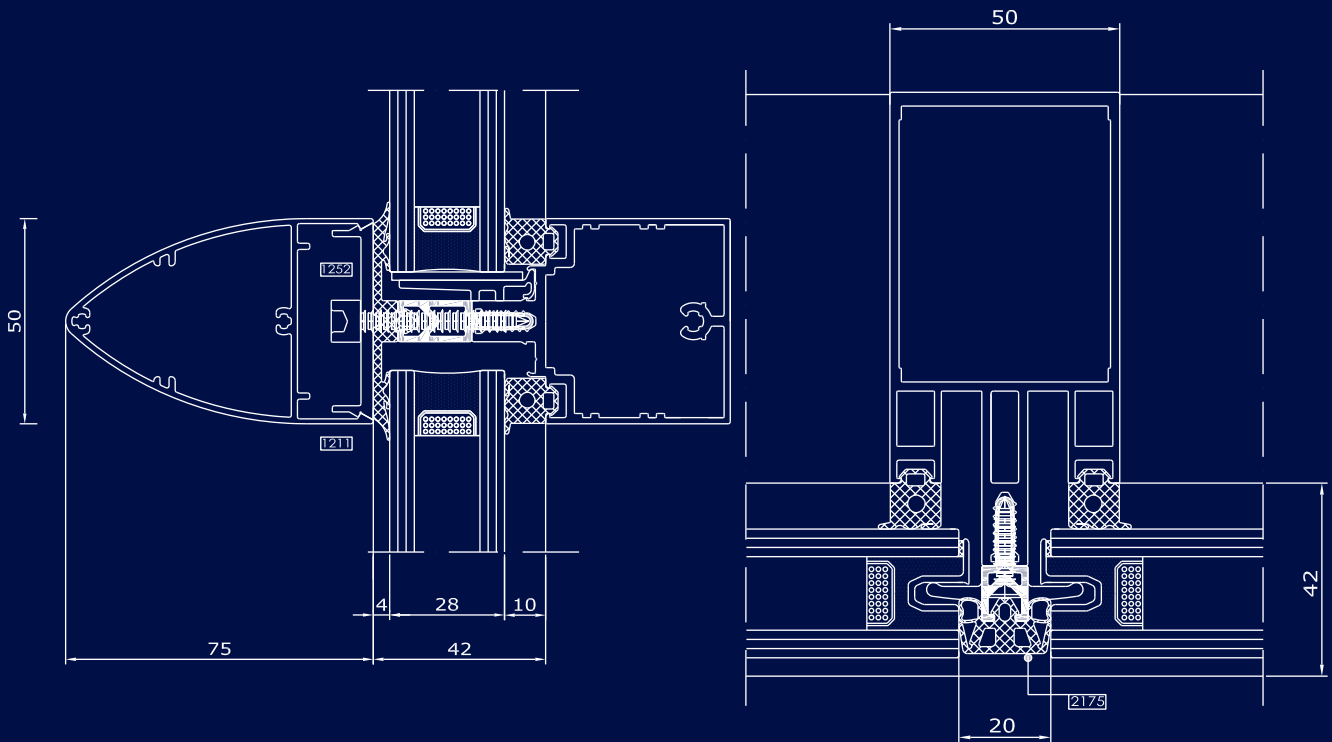

on-time

Comar 6EFT Facetted Solutions.

General arrangement showing Comar 6EFT facetted solutions in 7.5° increments for internal/external angles.

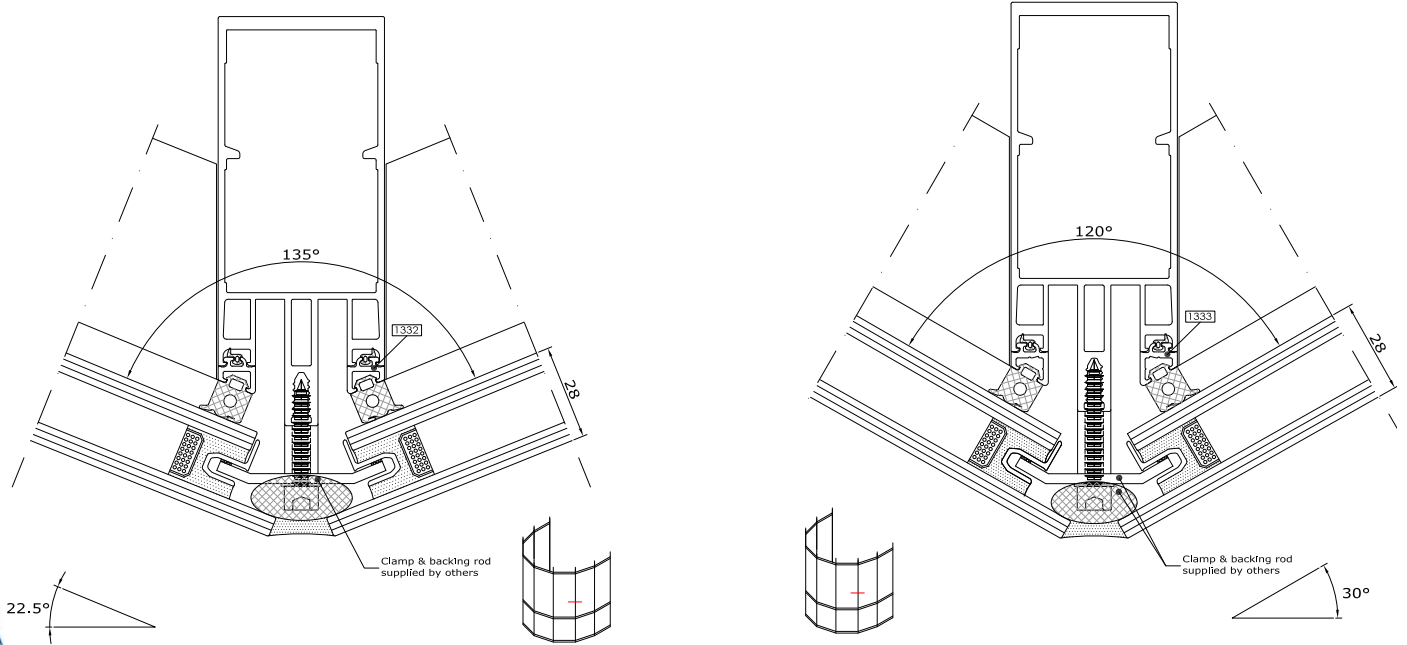

sustainable

Today's world calls for us all to be more conscious of our environment. In 1998 the world recognized this by signing the Kyoto Agreement. The Kyoto Agreement directly affected the construction industry by demanding that buildings become more thermally efficient. With these demands longevity, thermal efficiency, sustainability and recyclability are now critical factors in construction.

Why Aluminium...

Aluminium provides a unique solution for today's construction needs. Aluminium is light, strong, durable and flexible which provides tremendous potential for achieving even the most demanding design brief. Two-thirds of the energy required to extract aluminium is supplied by environmentally friendly, hydroelectric power. Couple this with the recyclability of aluminium and aluminium is the ideal choice for windows, doors and façades.

Longevity

Unlike some alternative building materials, aluminium offers an almost unlimited life expectancy. A notable example of this is the Statue of Eros in London's Piccadilly Circus, which has only just been cleaned and renovated, and The Empire State Building, the latter being the first building to use anodised aluminium. Aluminium does not age like other organic materials and needs no protection from ultra-violet light. Aluminium can be polyester powder coated or anodised to a variety of colours, which enhances the material's natural durability. Comar's powder coaters guarantee their finishes for 25 years and anodisers for 30 years.

Sustainability...

The recycling process now produces high quality aluminium, which is very cost effective and can be carried out on an indefinite number of occasions without impairing the quality in any way. It is a very durable material and has very low maintenance requirements, therefore reducing the whole-life cost. It is long lasting and can withstand the ravages of the most extreme conditions. Aluminium is an excellent material to use in marine and coastal environments, as the effect of sodium chloride is minimal.

Sustainability concerns are alleviated by the knowledge that we have at least 300 years of known reserves of the raw material, Bauxite, and this does not allow for the fact that 70% of all aluminium used is recycled at the end of its product life.

Thus, with an ever increasing proportion of re-cycled material in use, aluminium can be accurately described as the ultimate sustainable material.

Recycling Check List

"The recyclability of aluminium – one of its unique properties along with strength, durability and corrosion resistance – has led to its increased use in construction over recent years. Used aluminium is valuable and is easily and endlessly recycled without quality loss. The material is very rarely 'lost' entirely because of this."

Important issues to note are:

- The quality of aluminium is not impaired by endlessly recycling
- Re-smelting aluminium saves up to 95% of the energy needed to produce the primary product
- It is the most cost effective material to recycle
- The overall market for used aluminium is steadily growing, so the more aluminium there is in a product, the more chance it has of being recycled
- The recycling rate of used aluminium products in building is over 80% (over 95% in transportation and 30% in packaging)
- 30% of the 1.9 million tonnes of aluminium used in Europe in 1997 came from recycling

Source: Council for Aluminium Building and The European Aluminium Association.

Standards

BS EN ISO 14001 :	Comar is an ISO 14001 registered firm, certificate number: EMS 555373
BS EN ISO 9001 :	Comar is an ISO 9001 registered firm, certificate number: BSI: FM553615
BS-EN 755:	Aluminium alloy extrusion
BS-EN 485:	Aluminium alloy sheet
BS-EN515:	Aluminium and aluminium alloys – Wrought products temper designations
BS 4255 Part-1 :	Gaskets
BS-EN573-3:	Aluminium and aluminium alloys – Chemical composition – Wrought products – part 3
BS-EN755-2:	Aluminium and aluminium alloys – Extruded profiles – part 2: Mechanical properties.
BS-EN755-9:	Aluminium and aluminium alloys – Extruded profiles – part 9: Profile tolerances.
BS-EN12020-1 :	Aluminium and aluminium alloys – Extruded precision profiles – part 1: inspection and delivery
BS-EN12020-2:	Aluminium and aluminium alloys – Extruded precision profiles – part 2: tolerances on dimension and form.
BS 4873:	Specification for aluminium alloy windows.
BS 6375 Part 1 :	Classification for weather tightness.
BS368:	Method of testing windows
BS 5713:	Hermetically sealed flat double glazed units
BS6262:	Code of practice for glazing of buildings
BS6496:	Specification for powder organic coatings to aluminium alloys for external architectural purposes
BS1615:	Method of specifying anodic oxidation coatings on aluminium and its alloy
BS3987:	Specification for anodic oxide coatings for external architectural purposes
BS6399 Part 2:	Code of practice for wind loads
C.W.C.T.	(Centre for Window & Cladding Technology)

Kitemark BSi Licences:

KM 578159 - BS 4873	Systems Supplier Aluminium alloy windows
KM 578160 - BS 4873/PAS24	Enhanced security performance of windows for domestic applications
KM 590092 - PAS 23-1 & PAS 24-1	System Supplier - General and Enhanced Security Performance Requirements for Door Assemblies
KM 593756 - BS 4873/PAS24	Door System Supplier

Secured by Design Licence Holder

The Parkside Group Ltd

Unit 5, The Willow Centre
17 Willow Lane, Mitcham
Surrey CR4 4NX

Tel: +44(0) 20 8685 9685

Fax: +44(0) 20 8646 5096

Email: projects@parksidegroup.co.uk

Web: www.comar-alu.co.uk

Technical Back-Up

An experienced Sales Team covers the UK while the Technical Department offers an unsurpassed design and installation advice service to designers, specifiers and fabricators; Simply call: +44(0) 20 8685 9685

For More Information

To find out more about this or any other Comar Architectural Aluminium System, or to obtain your personal copies of the Comar Technical Manuals call: +44(0) 20 8685 9685 or fax on: +44(0) 20 8646 5096