

Copyright and ownership of this drawing is vested in EFT, Euro Facade Systems Ltd, whose prior written consent is required for its use, reproduction or for publication to any third party. All other rights reserved. Subject to modifications.

7

Installation
Comar 6EFT

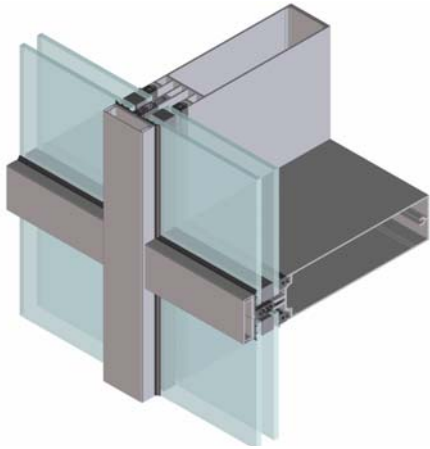

Capped

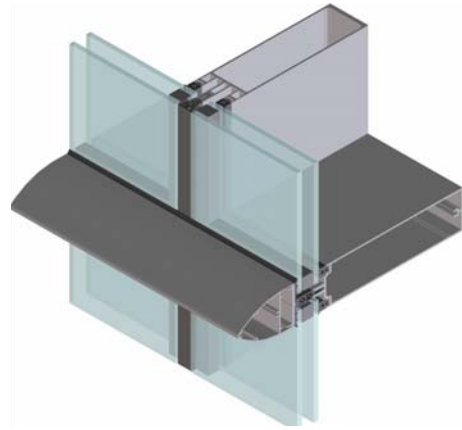

2sided SGH

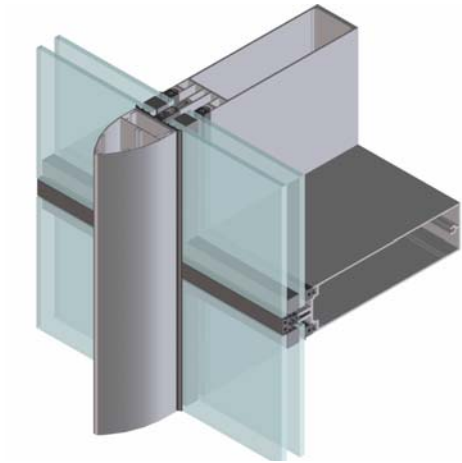

2sided SGV

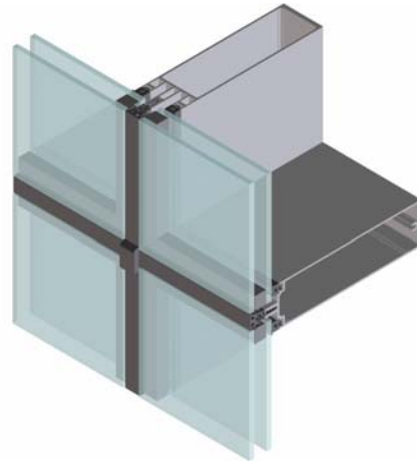

4sided SG

Changes reserved
Sous reserve de modifications
Änderungen vorbehalten

Issue: 05
Date: 10-16

Installation Guide for Erecting Comar 6EFT Curtain Wall System.

1 On-site / project conditions

The structural surface to which the brackets will be attached must be rigid steelwork or concrete floor-slabs and must be within tolerances.

- The fixing bolts and inserts must be adequate for structural requirements and site conditions. ([Please consult your structural engineer](#))

2 Wall Brackets

Available are standard brackets CW671, CW672, CW673 & CW674. Strength of the bracket and the size of fixing bolts are to be verified and specified by a structural engineer.

Single or a two-field span?

- Wall brackets must be installed in position as defined and be lined out to allow the mullion to expand freely.
- In case of **a single field span**, one bracket should transfer the wind/dead load and should be fixed. The second bracket (or coupling sleeve) must slide to allow the mullion to expand.
- In case of a **two-field span**, one bracket should transfer the wind/dead load and should be fixed. The middle and the third bracket (or coupling sleeve) must slide to allow mullion to expand.

Please refer to EFT Technical Manual section 7 for further details of wall brackets, fixing methods, fixing materials, expansion joints and the choice of a hanging or standing construction.

[For details please refer to EFT drawings 7.00 – 7.05.](#)

3 Coupling of Mullions

If the building height requires coupling of mullions, a mullion sleeve of sufficient length must be used. (Minimum length should be 600mm; length depends on position of mullion coupling and wall bracket. Length to be decided and verified by a structural engineer). Also the EPDM mullion expansion moulding (EFT 2030) needs to be installed in such a way to allow the mullion to expand.

- Fix mullion sleeve to one (end of) mullion only (7.01 or 7.02).
- Apply sealant at drainage channel in the top mullion and install EPDM coupling mould EFT 2030.
- Clean off excess sealant.

[For details please refer to drawings 7.03, 7.05 & 7.40.](#)

Installation Guide for Erecting Comar 6EFT Curtain Wall System.

4 Mullion-Transom Connection

The Mullion-Transom connection is designed so that notched transoms are secured to the gasket groove on the mullions.

There are several installation methods such as:

1. Fasten mullions first and clip in transoms afterwards.
2. Fasten pre-fabricated ladders (units of practical sizes) and clip in transoms connecting the ladders. [\(Please refer to drawing 7.11\)](#)

The second option is the most practical method, however, the choice of installation method will depend on the size of the project, the preferred working methods of the fabricator/installer, possible access to the building as well as installation equipment available etc.

For all methods of installation, different mullion-transom cleats and connection components are available:

- When mullions or ladders are installed already, use spring-loaded cleat, EFT 2310, for transom fixing.
- Prefab units (ladders) screw EFT 3022 or transom cleat for transom fixing.
- Transoms must be fixed overlapping the mullion and must be sealed by a special EPDM seal EFT 2028 and fixed with screws EFT 3021.
- Set torque to fix transom screws EFT 3021 at a turning moment of 2,5 Nm,
- Allow for a minimum of 0.5 mm space for expansion at both ends of transoms.

[For details please refer to drawings 7.34.](#)

5 Spandrel and glazing adaptors

For different glass and spandrel panel thickness or segmented facades, glazing adaptors are required, the following needs to be observed:

- Seal the gasket groove at the transom ends.
- To seal the vertical glazing adaptor inject sealant at the end of the adaptor and apply sealant at edges of the horizontal glazing adaptor.
- When the vertical glazing adaptor is bridging a coupling of 2 mullions it is advisable to have a joint gap to the adaptor equal to that of the mullion, to be located below the mullion joint. The upper adaptor to be fixed in position above mullion joint. Apply sealant to joint.
- Factory fitting of adaptors to be screw fixed with minimum of two screws with fixings not more than 1m apart.

Installation Guide for Erecting Comar 6EFT Curtain Wall System.

6 Thermal break / Isolator

- Install the correct thermal break size as advised as per glazing tables.

7 Glazing gaskets and EPDM corner mouldings (inner seal)

The inner seal gasket is the most important seal to avoid air and water ingress, Comar 6EFT is pressure equalised allowing small amounts of water into the glazing rebate which is then drained out via the mullions.

Drainage diverters are designed to drain the water out of the system and sufficient drainage and pressure equalisation slots must be punched into the pressure plates, pressure-plate gaskets and cover caps.

- Apply a sealant into glazing groove before installing the corner moulding.
- Cut EPDM glazing gasket size plus approx. 5 % to ensure compression of the gaskets and allow for shrink back. Apply bonding compound and slide/bond gasket into its position.
- Clean off excess sealant.

For details please refer to glazing tables in section 3 and drawings 7.12 – 7.15, 7.35 & 7.36

8 Drainage diverter

- Select the correct drainage diverter for mullion drainage as per glazing tables.
- Install drainage diverter and inject sealant mastic into hole provided. To achieve a watertight seal, mastic must cover all edges.
- Apply mastic to seal the drainage diverter to the thermal break.

For details please refer to glazing tables in section 3 and drawings 7.12, 7.15, 7.37 & 7.38

9 Glass setting blocks and glazing

- Clean out debris from the glazing rebates and ensure that the drainage routes are clear of obstruction.
- Clip-fit proprietary glass setting blocks into position on the transom making sure that they do not interfere with the drainage grooves. (Approx. 50 mm from corner edge)
- Position 1*, 2* or 3* mm thick location blocks (of correct size) onto fitted glass setting block, ensuring that it is positioned centrally in accordance with glazing tables.

1mm block (**5mm gap) for Comar 6EFT 2sided vertical and Comar 6EFT 4sided curtain walling.

Installation Guide for Erecting Comar 6EFT Curtain Wall System.

2mm block (**7mm gap) for Comar 6EFT curtain wall and Comar 6EFT 2sided horizontal with setting blocks XX2301, XX2305 & XX2306, 3mm block(**7mm gap) to all other glass setting blocks.

- In accordance with current relevant Health and Safety legislation, use proprietary glass suckers to lift the glass unit, onto the location blocks and fit into the glazing rebate. Ensure that there is a minimum of 5** to 7** mm ventilation gap between the edge of the glass pane and the curtain wall frame, for the full perimeter of the glass unit.
- Check that the internal glazing gasket fits against the glass face correctly with no tucks in the gasket leg.
- Fix glazing aids to hold the glass unit into its position.

[For details please refer to drawings.](#)

10 Pressure-plate gasket.

The pressure-plate outer gasket stops water ingress into the system; to ensure a tight seal close attention to this gasket is required in the cruciform area.

Comar 6EFT curtain wall has 2 options for the outer transom gasket e.g.

1 [Single](#) gasket EFT 2162 (or 2163) along with pressure plate EFT 1252 or 1252

2 [Duo*](#) gasket combination EFT 2150 + 2150 along with pressure plate EFT 1251

When to use [Single or Duo*](#) gasket.

Single and Duo gasket options can be used for all EFT curtain walls.

For single transom gasket conditions, EFT 2162 is sealed (butt joint) against the outer vertical gasket EFT 2162.

For duo gaskets conditions, the vertical outer gasket EFT 2162 overlaps the horizontal Duo* gasket and is not sealed.

- Remove vertical fixed glazing aids, at one side of the glass unit only.
- First select the correct vertical pressure plate gasket (as detailed in the glazing tables) minimising butt joints. All butt joints must be sealed.
- Cut gasket straight, size plus approx. 2 % to ensure compression of the gaskets and allow for shrink back, make sure that gasket is not stretched.
- Ensure that drainage or pressure equalisation slots are correctly positioned.
- **Fix vertical pressure-plate** ([see item 11](#))
- Remove horizontal fixed glazing aids.
- Fix horizontal pressure-plate-gasket and cut this gasket straight. (Plus approx. 2 %)

Installation Guide for Erecting Comar 6EFT Curtain Wall System.

- Apply sealant against vertical pressure-plate-gasket and slide horizontal gasket against vertical gasket into position.

[For details please refer to drawings.](#)

11 Pressure plates

- Pressure plate screw connections should be spaced at intervals of 200 mm. The first and last screw should be fixed at 25mm from the ends of the pressure plate and 50mm from the centre of mullion or transom cruciform.
- Use correct screw-type and length in accordance with glazing tables.
- Install vertical pressure plates first, [as mentioned under item 10](#)
- Check both the outer gasket and pressure plate, there should be no protrusion in the outer pressure plate gasket and no depression in the pressure plate, it is advisable to set the torque moment of 3,5 – 4,5 Nm, (specific project requirements might require a different value)
- Make sure the slot for drainage and pressure equalisation is positioned correctly.

- When coupling is required (at least every 6.45 m), leave sufficient space between the pressure plates to allow for expansion.
(Typically there is approximately 1mm expansion per metre of profile but this varies depending on location of the curtain wall and colour of cover-cap which should both be considered)
- Install horizontal pressure-plate and leave a minimum of 2 mm space between vertical cover cap and horizontal pressure-plate to allow for expansion.
(Cutting size; C.T.C - 54 mm)

[For details please refer to drawings.](#)

12 Cover caps

Vertical cover caps need to be 3mm wider than the horizontal to ensure that there are no raw edges.

Cover caps have a typical edge radius of 1,5mm, edge radii for even distribution of the powder coating layer.

Vertical cover-caps

- First install correct vertical cover-cap.
- When coupling is required (at least every 6.45 m), leave sufficient space between the cover caps to allow for expansion.
(Typically there is approximately 1mm expansion per metre of profile but this varies depending on location of the curtain wall and colour of cover-cap which should both be considered)
- For some cover caps (75mm and higher) a coupling strip will be available to align the cover caps.
- Fix one screw in the cover-cap and pressure-plate at transom (cruciform) location to let cover-cap expand in one direction only.

Installation Guide for Erecting Comar 6EFT Curtain Wall System.

- Higher cover caps need to be fixed at each cruciform location, preferably concealed underneath the transom cover and if the vertical span exceeds 1.5m, additional fixing points will be required.
(A special designed pressure plate (EFT 1253) is available to ease the fixing)
- If drainage is chosen through the vertical cover cap it is advisable to divert the majority of water (drained out of the mullion) to the outside approx. every 20 m
A location can be where cover caps are connected.

[For details please refer to drawings.](#)

13 Other?

Further questions or suggestions; or if the standard solutions don't meet your requirements, please do not hesitate to contact our office.

Installation

7

Comar 6EFT

Exploded typical detail Fully capped

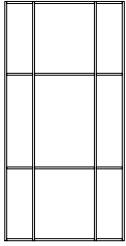

7.00

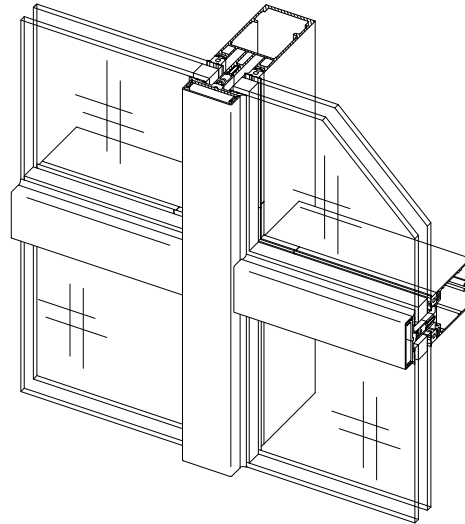
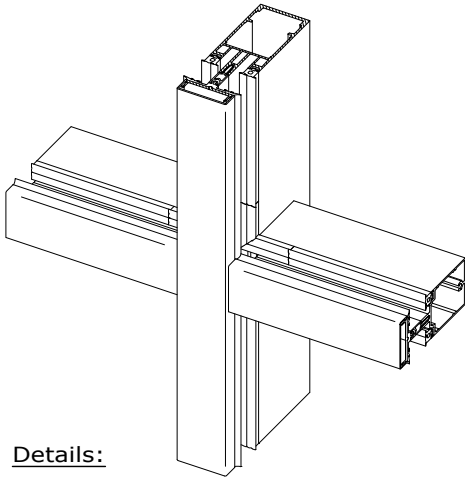

Details:

1. One substructure for all curtain wall types (Fully Capped / 2sided SGH / 2sided SGV / 4sided SG)
2. Controlled drainage system (mullion drained) - drainage diverter
3. Thermal break
4. Mullion-Transom step-cut & sealed by EPDM moulding
5. Ladder (unit) construction or stick build
6. Moulded EPDM corners available
7. Mullion / Transom pressure plate gasket
8. Pressure plate
9. Mullion cover cap
10. Transom cover cap

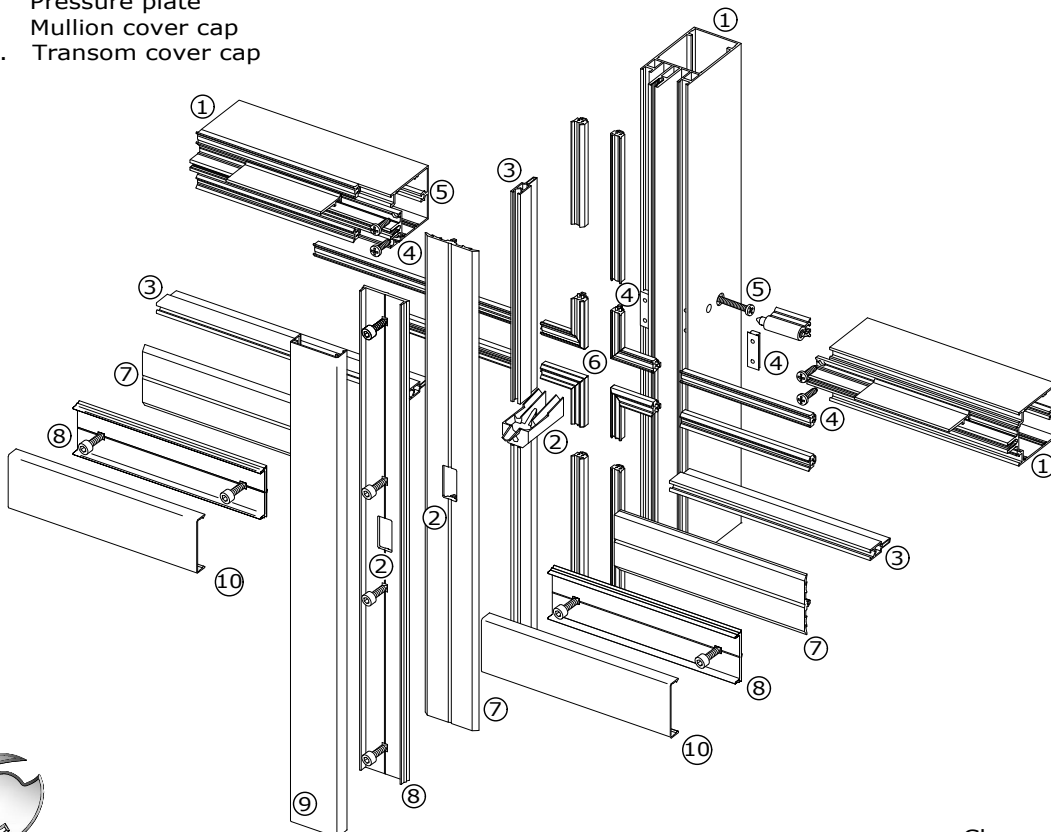

Copyright and ownership of this drawing is vested in EFT, Euro Facade Systems Ltd, whose prior written consent is required for its use, reproduction or for publication to any third party. All other rights reserved. Subject to modifications.



Exploded typical details Horizontal cover cap (2sided SGH)

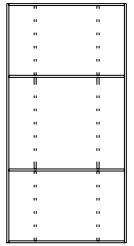

7.01

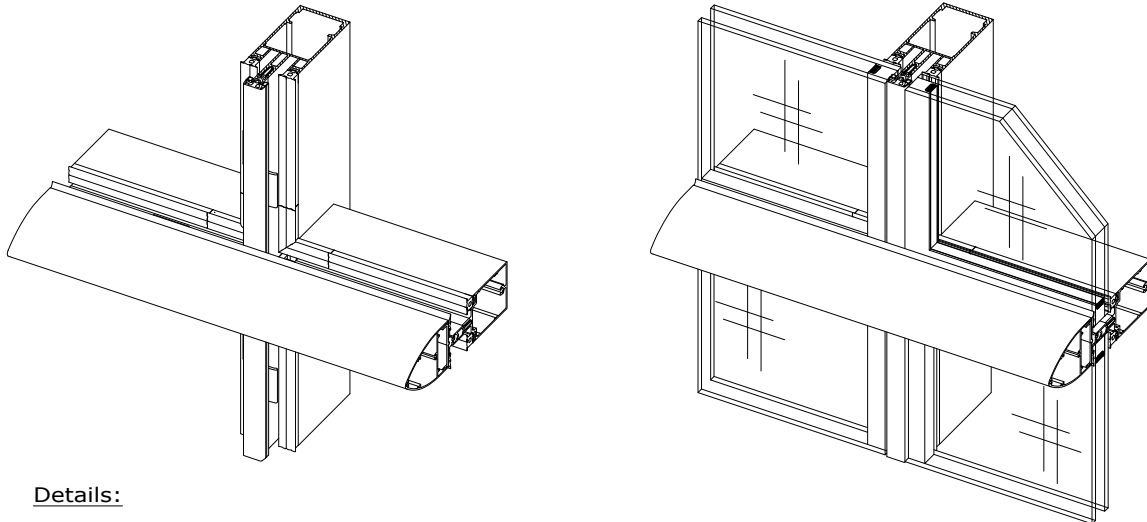

Details:

1. One substructure for all curtain wall types (Fully Capped / 2sided SGH / 2sided SGV / 4sided SG)
2. Controlled drainage system (mullion drained) - drainage diverter
3. Thermal break
4. Mullion-Transom step-cut & sealed by EPDM moulding.
5. Ladder (unit) construction or stick build
6. Moulded EPDM corners available
7. Transom pressure plate gasket
8. Transom pressure plate
9. Mullion joint gasket
10. Transom cover cap
11. Mullion clamping system

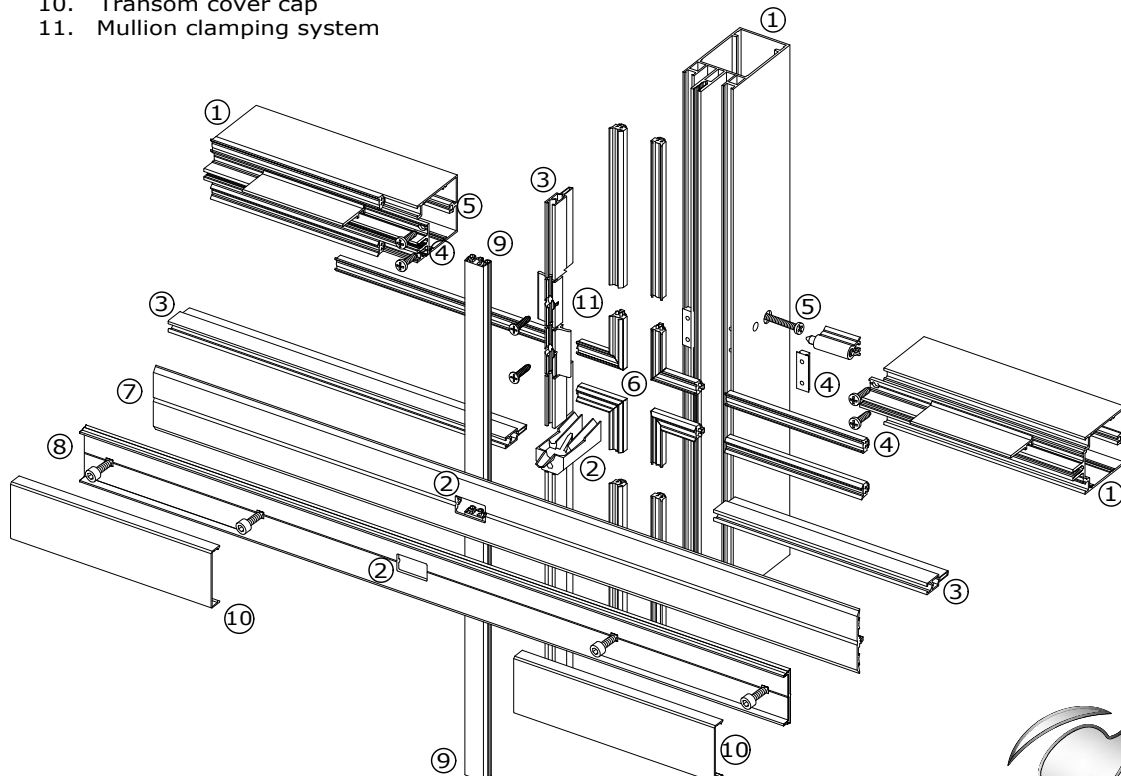

Changes reserved
Sous reserve de modifications
Änderungen vorbehalten

Issue: 05
Date: 10-16

Installation

7

Comar 6EFT

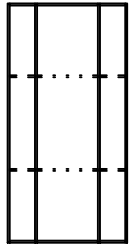

7.02

Exploded typical detail Vertical cover cap (2 Sided SGV)

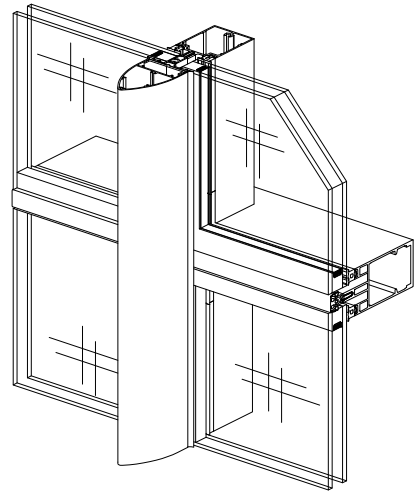
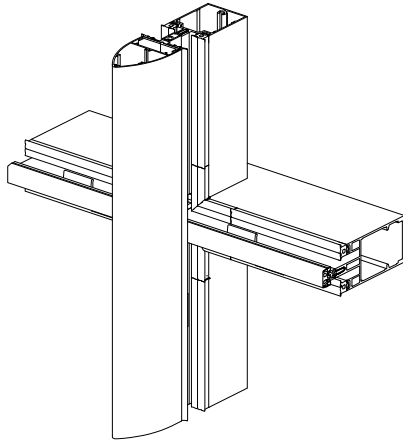

Copyright and ownership of this drawing is vested in EFT,
Euro Facade Systems Ltd, whose prior written consent is required
for its use, reproduction or for publication to any third party.
All other rights reserved. Subject to modifications.

Details:

1. One substructure for all curtain wall types, Fully Capped, 2sided SGH, 2sided SGV & 4sided SG.
2. Controlled drainage system (mullion drained) drainage diverter
3. Thermally broken.
4. Mullion-Transom step-cut & sealed by EPDM moulding.
5. Ladder (unit) construction or stick build.
6. Moulded EPDM corners available.
7. Continuous pressure plate gasket.
8. Glazing clamping system into DG unit.
9. Continuous pressure plate gasket.
10. Glass setting Block

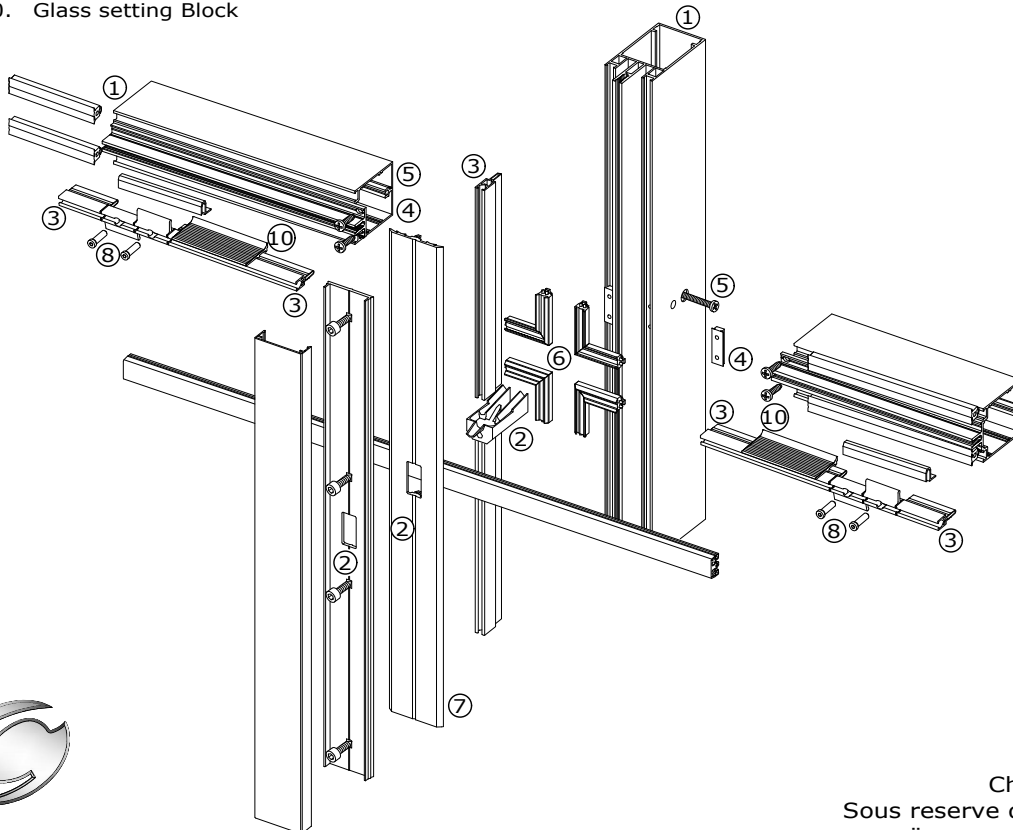

Exploded typical details Four sided structural EFT (4sided SG)

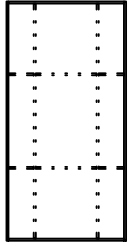

7.03

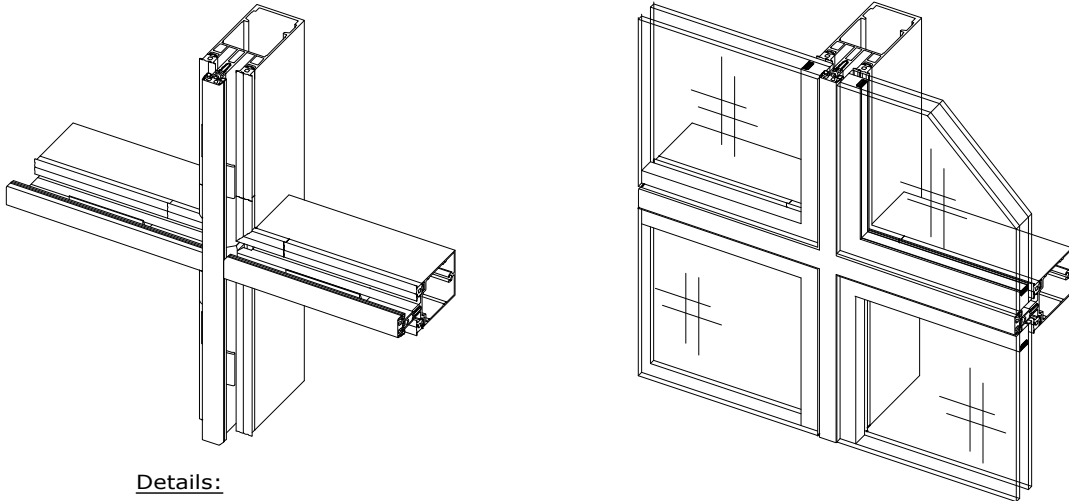

Details:

1. One substructure for all curtain wall types, Fully Capped, 2sided SGH, 2sided SGV & 4sided SG.
2. Controlled drainage system (mullion drained) drainage diverter/cover
3. Thermally broken.
4. Mullion-Transom step-cut & sealed by EPDM gasket.
5. Ladder (unit) construction or stick build.
6. Moulded EPDM corners available.
7. Joint cruciform gasket.
8. Glazing clamping system into DG unit.
9. Glass setting block

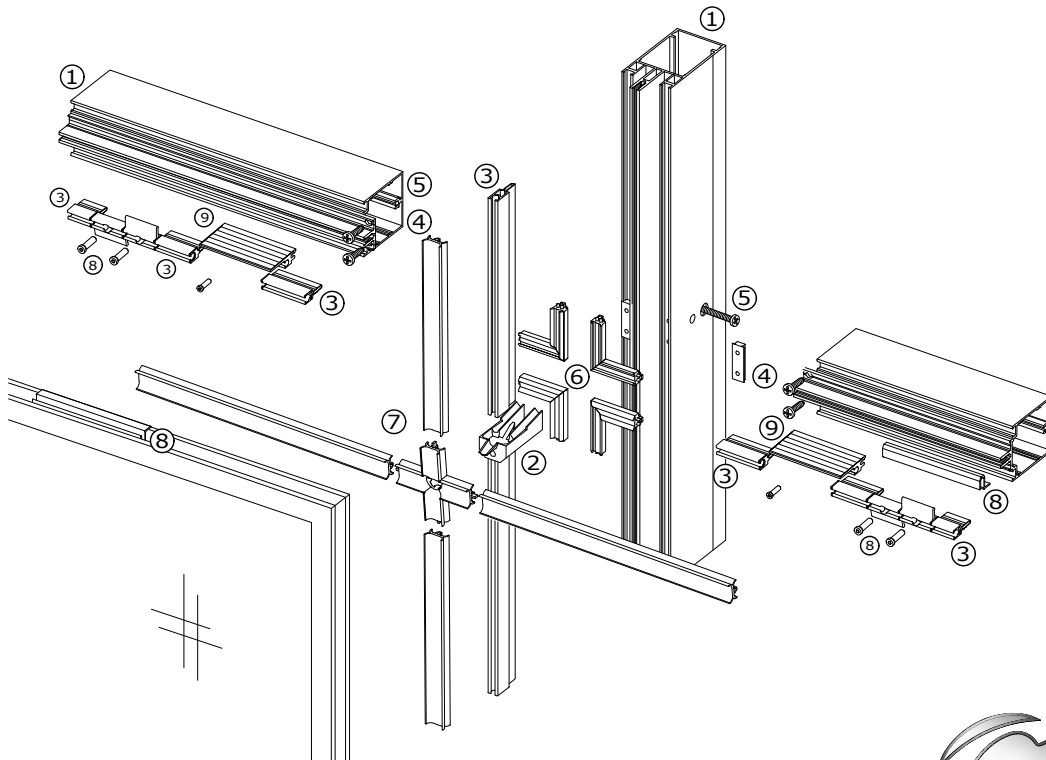

Changes reserved
Sous reserve de modifications
Änderungen vorbehalten

Issue: 05
Date: 10-16

Installation

7

Comar 6EFT

Fixed between floors

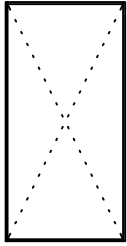

7.04

Fabricators Guide

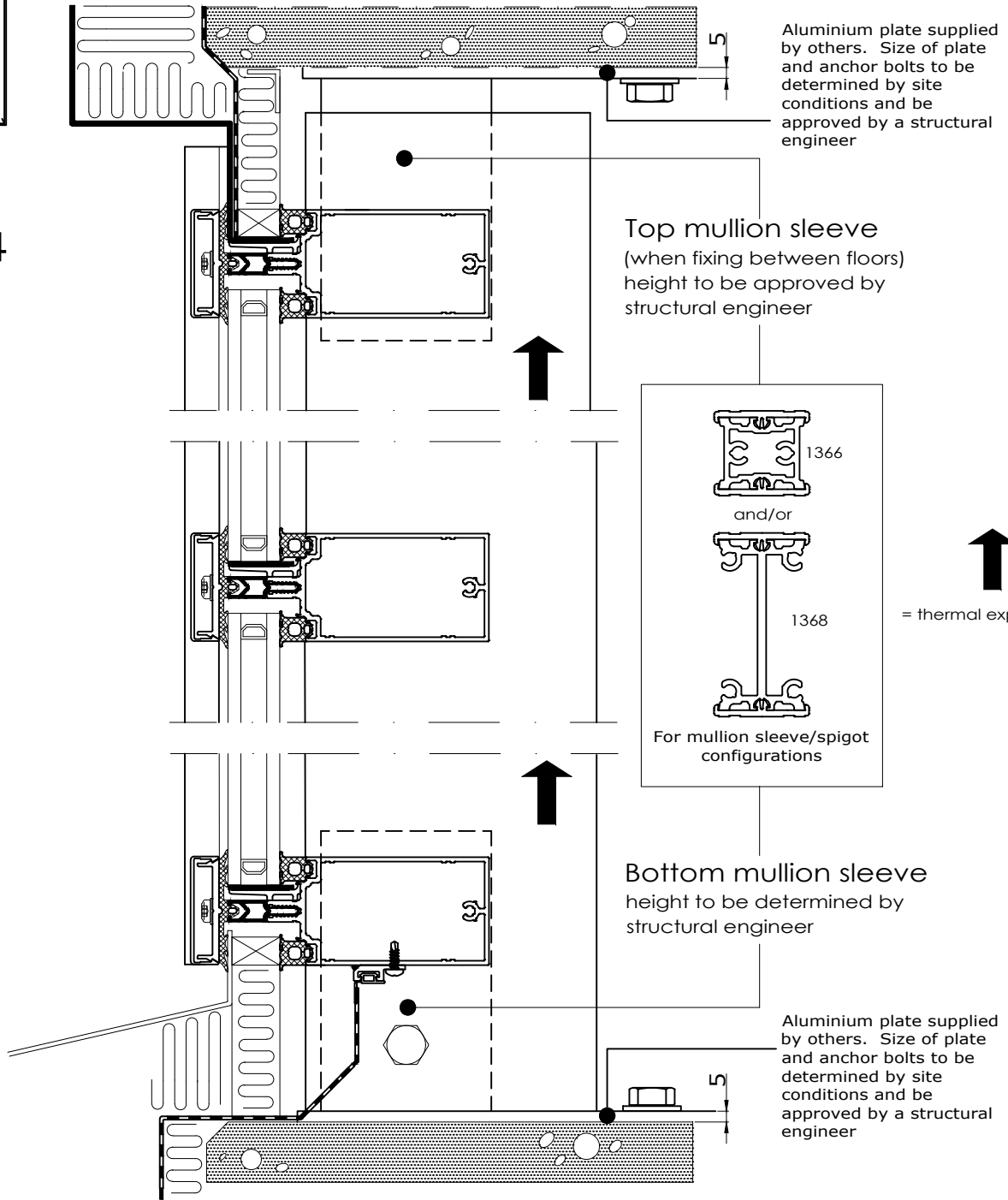

* Standing Construction *

Copyright and ownership of this drawing is vested in EFT, Euro Facade Systems Ltd, whose prior written consent is required for its use, reproduction or for publication to any third party. All other rights reserved. Subject to modifications.

Brackets & Couplings

Copyright and ownership of this drawing is vested in EFT, Euro Facade Systems Ltd, whose prior written consent is required for its use, reproduction or for publication to any third party. All other rights reserved. Subject to modifications.

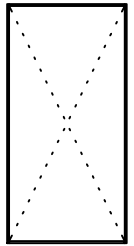

7.05

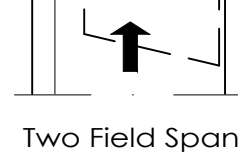
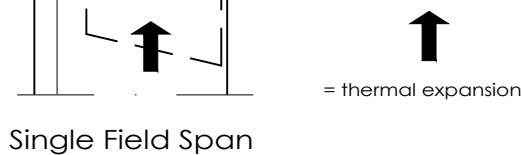
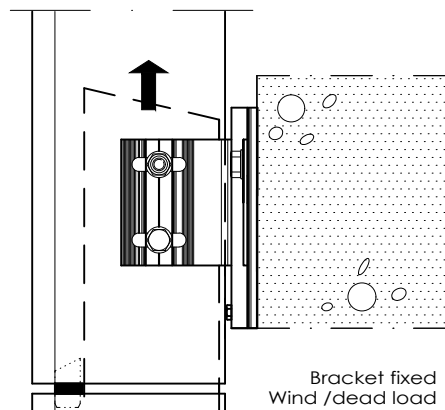
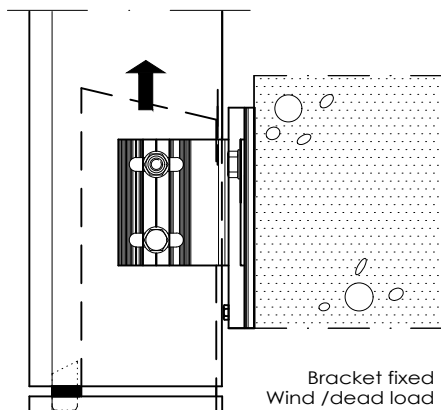
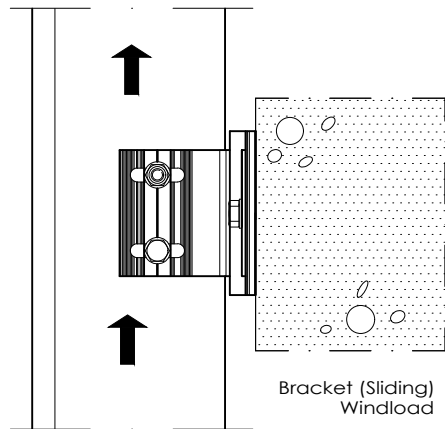
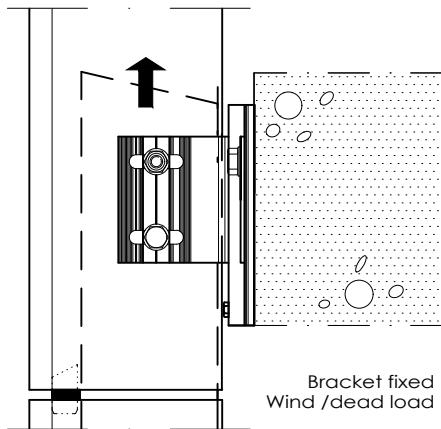
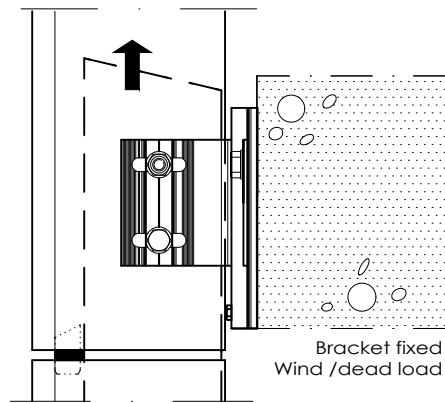
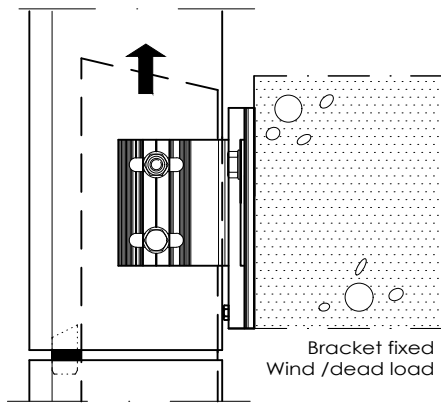

Fabricators Guide

* Propped Construction *

Changes reserved
Sous reserve de modifications
Änderungen vorbehalten

Issue: 05
Date: 10-16



Installation

7

Comar 6EFT

Brackets & coupling

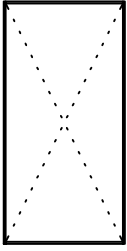

7.06

Fabricators Guide

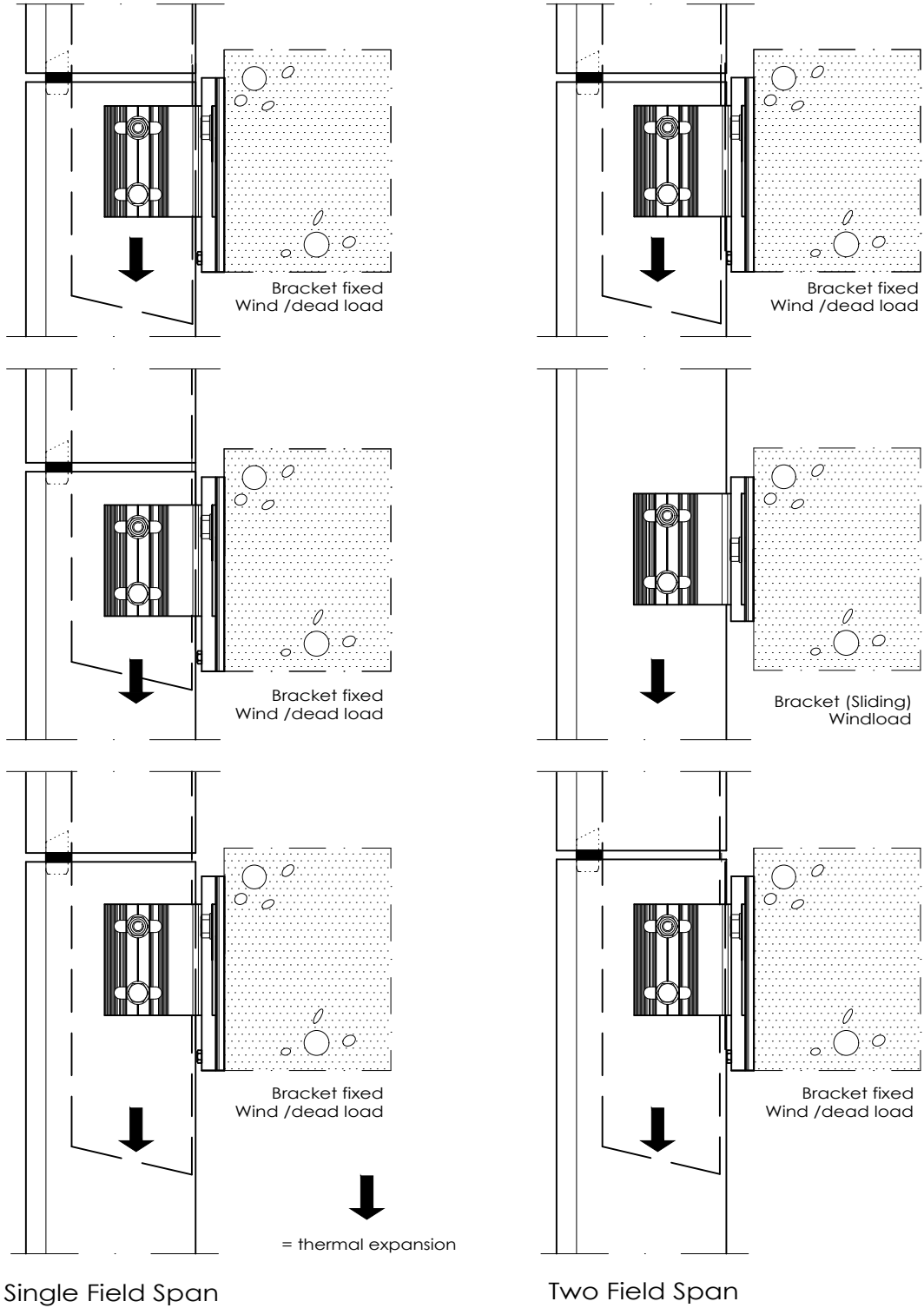

Single Field Span

Two Field Span

* Hanging Construction *

Copyright and ownership of this drawing is vested in EFT, Euro Facade Systems Ltd, whose prior written consent is required for its use, reproduction or for publication to any third party. All other rights reserved. Subject to modifications.



comar
ARCHITECTURAL ALUMINIUM SYSTEMS

Changes reserved
Sous reserve de modifications
Änderungen vorbehalten

Issue: 05
Date: 10-16

Copyright and ownership of this drawing is vested in EFT, Euro Facade Systems Ltd, whose prior written consent is required for its use, reproduction or for publication to any third party. All other rights reserved. Subject to modifications.

7

Brackets & Coupling

Installation
Comar 6EFT

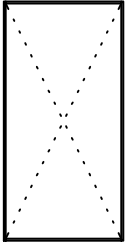

7.07

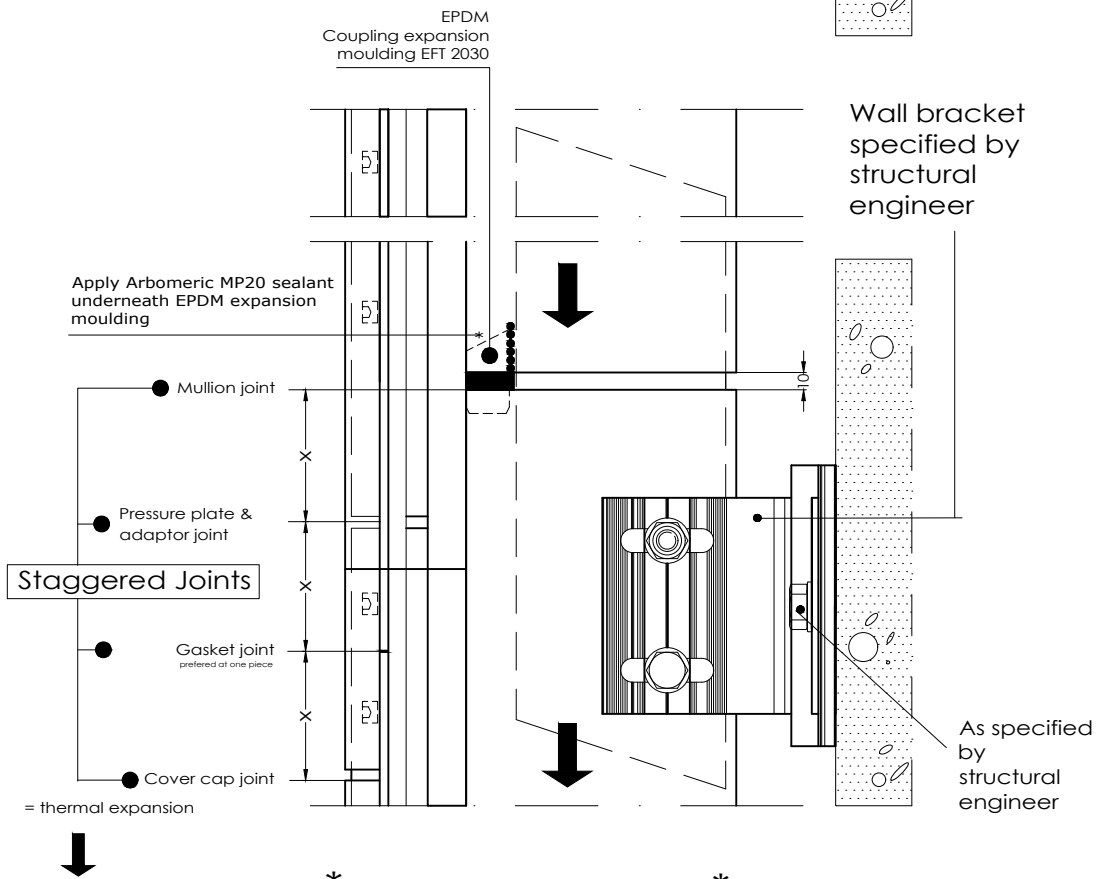
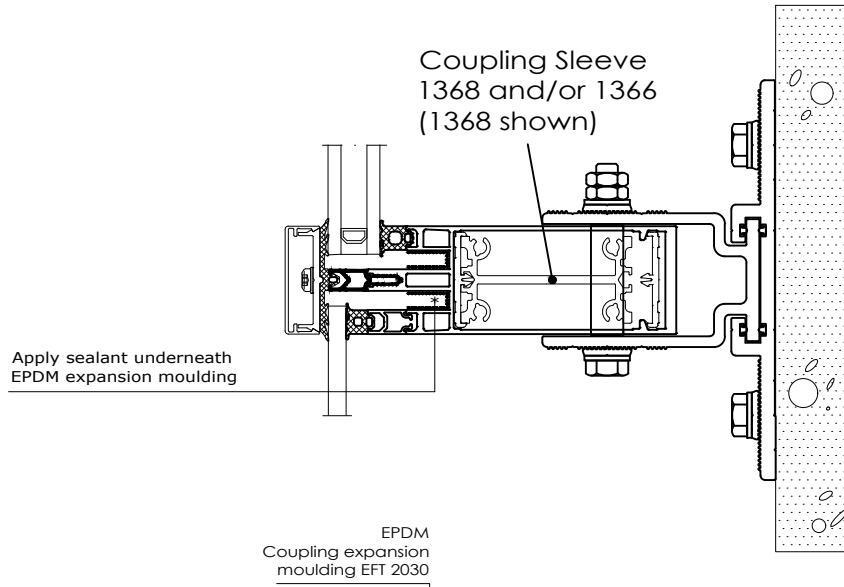

Fabricators Guide

Changes reserved
Sous reserve de modifications
Änderungen vorbehalten

Issue: 05
Date: 10-16



Installation

7

Comar 6EFT

Brackets & coupling

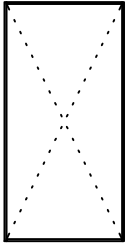

7.08

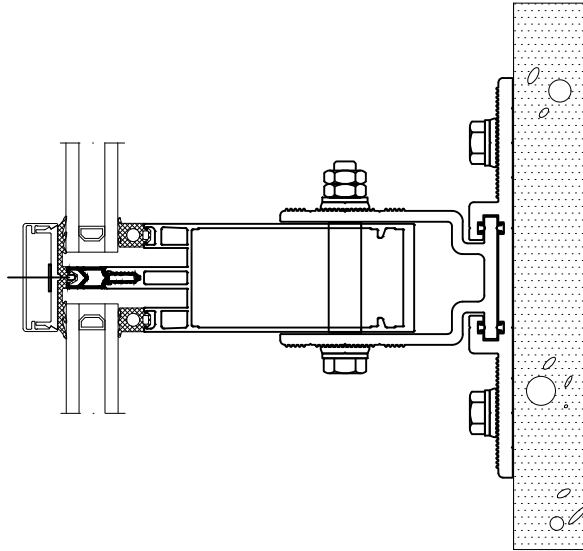

Fabricators Guide

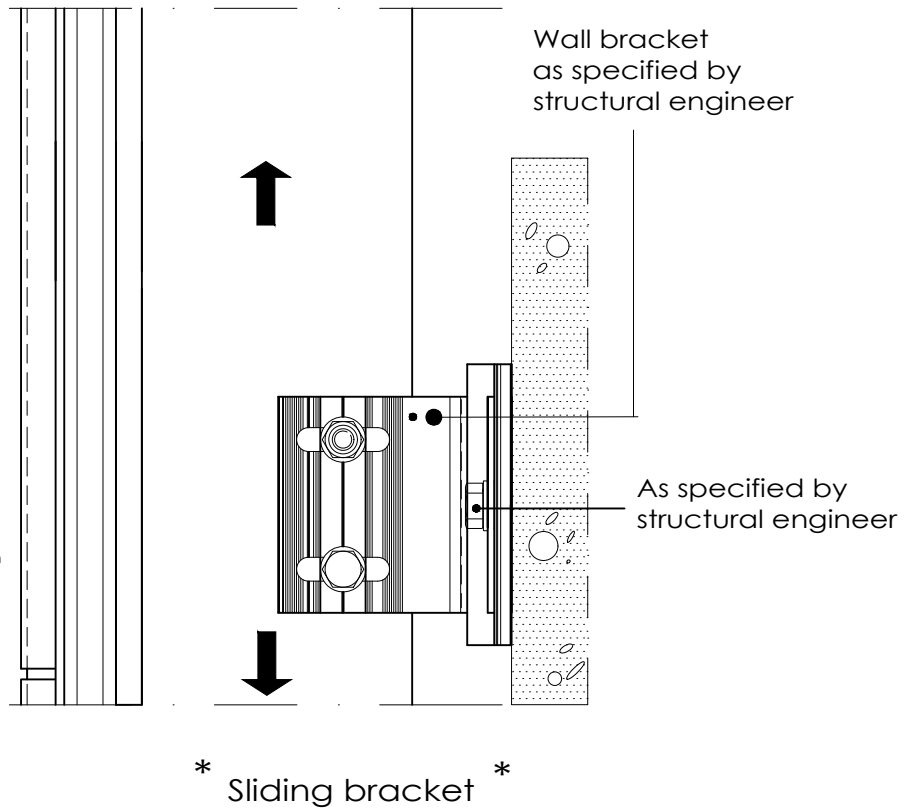
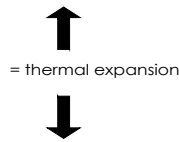

Copyright and ownership of this drawing is vested in EFT, Euro Facade Systems Ltd, whose prior written consent is required for its use, reproduction or for publication to any third party. All other rights reserved. Subject to modifications.

Mullion movement joint preparation

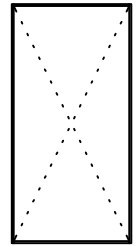

7.09

Copyright and ownership of this drawing is vested in EFT, Euro Facade Systems Ltd, whose prior written consent is required for its use, reproduction or for publication to any third party. All other rights reserved. Subject to modifications.

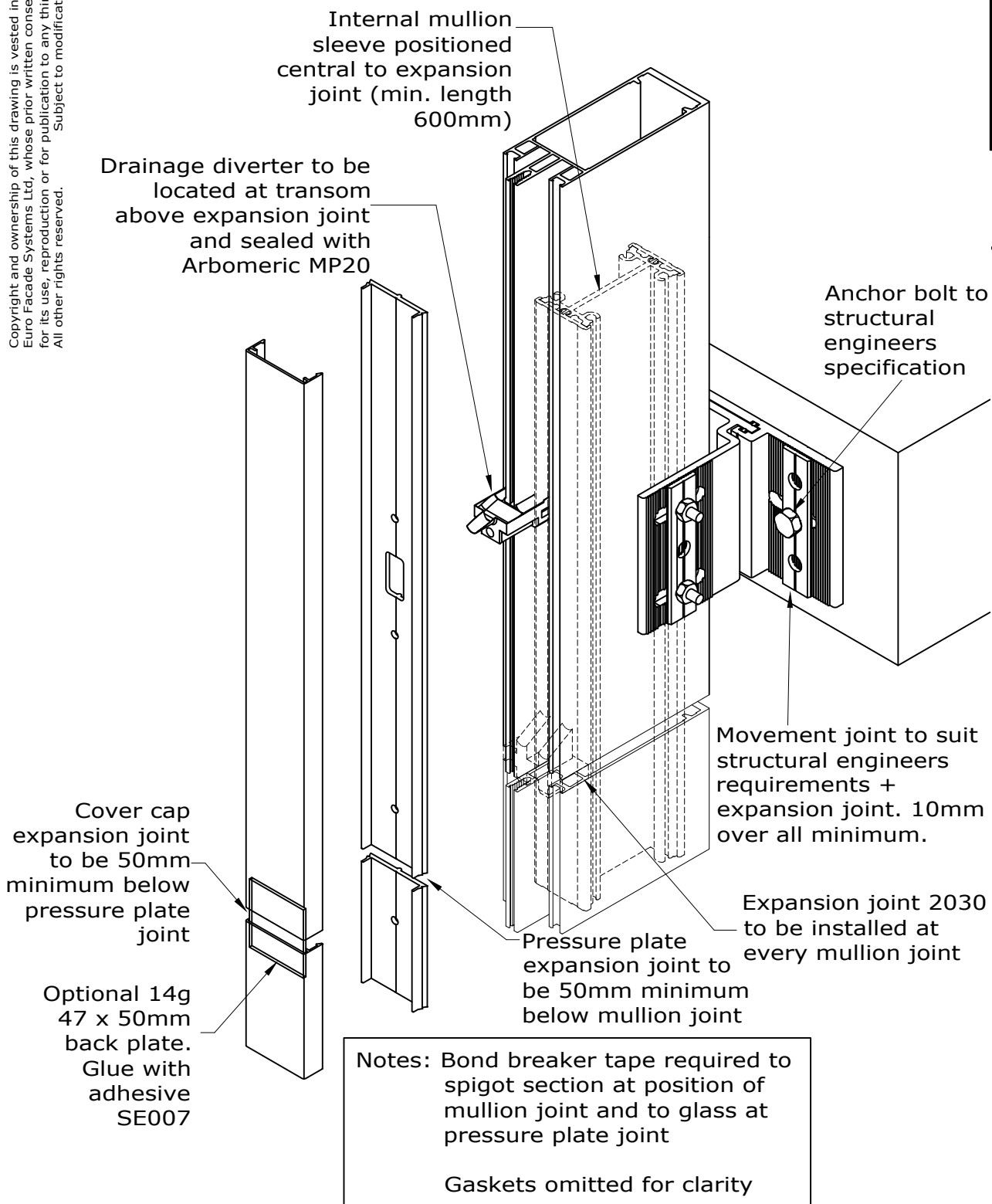

Changes reserved
Sous reserve de modifications
Änderungen vorbehalten

Issue: 05
Date: 10-16

Installation

7

Comar 6EFT

Mullion coupling 2030

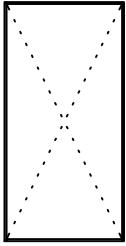

7.10

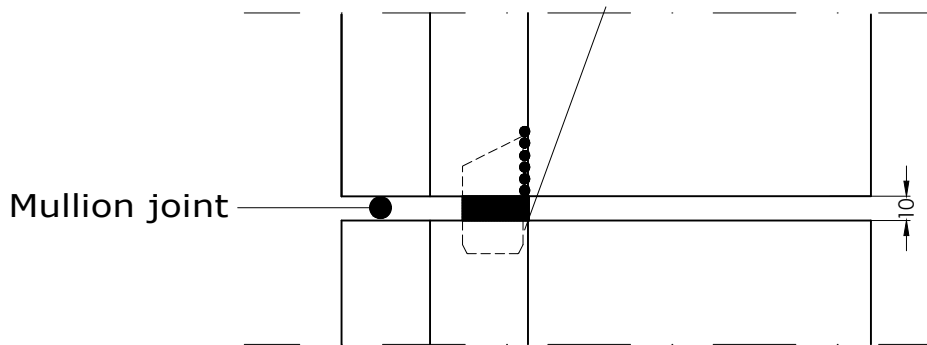

Copyright and ownership of this drawing is vested in EFT, Euro Facade Systems Ltd, whose prior written consent is required for its use, reproduction or for publication to any third party. All other rights reserved. Subject to modifications.

Fabricators Guide

Sealant to be applied at drainage channel in the upper mullion to all shown edges so the mullion coupling is sealed on all sides.

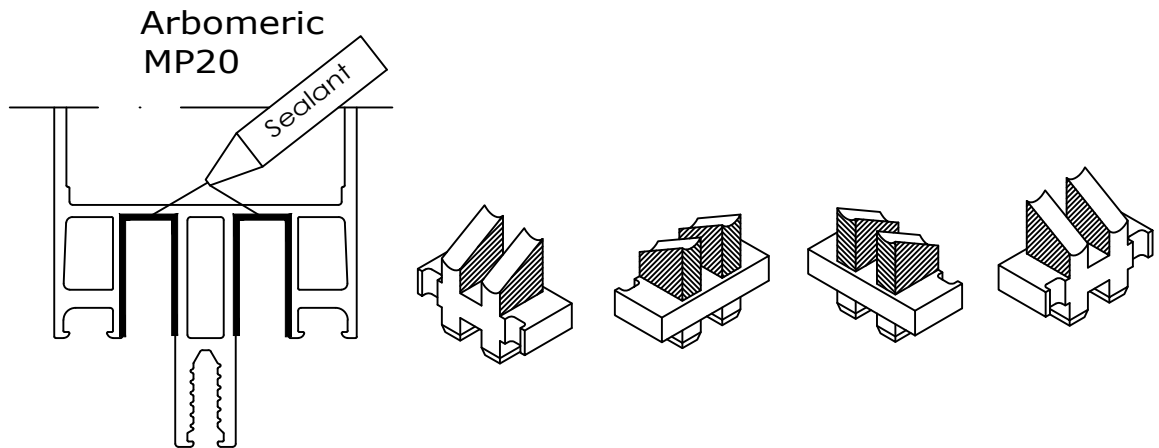

Fixing bracket hole preparation

Comar 6EFT

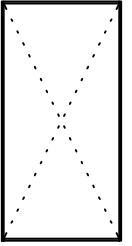

7.11

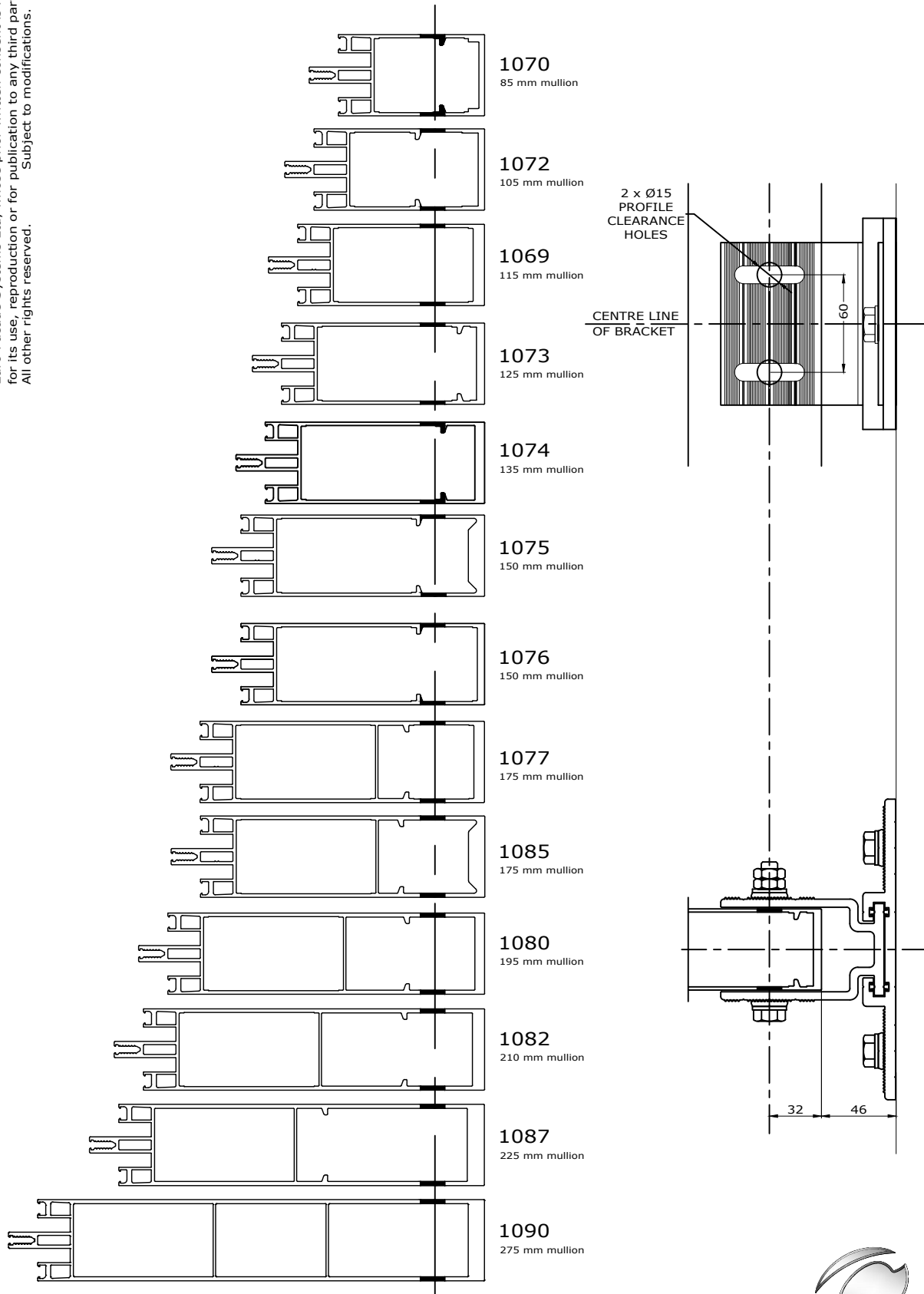

Copyright and ownership of this drawing is vested in EFT,
Euro Facade Systems Ltd, whose prior written consent is required
for its use, reproduction or for publication to any third party.
All other rights reserved. Subject to modifications.

Changes reserved
Sous reserve de modifications
Änderungen vorbehalten

Issue: 05
Date: 10-16

Installation

7

Comar 6EFT

Fixing bracket instructions Page 1

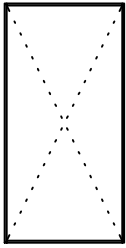

7.12

- 1 Back Plate
- 2 Guide Strip
- 3 Sleeve Channel
- 4 Bearing Tube
- 5 Locking Plate
- 6 Anchor bolts & nuts

Fit anchor bolts (6) specified by your structural engineer to the structure.

Offer the back plate (1) to the structure and line up to the center of the mullion and about the center of the mullions pre-drilled fixing holes.

Secure the back plate (1) with the locking plates (5) and the anchor bolt nuts (6) as shown.

To aid insertion of the sleeve channel fit the glide strips (2) into the back plate (1) leaving them proud by 5 to 6 mm and open out the ends as shown.

Insert the bearing tubes (4) into the mullion profiles pre-drilled holes (See page 7.17)

Insert the sleeve channel (3) into the back plate (1)

Align the sleeve channel (3) and locking plates (5) with the pre-drilled holes in the mullion.

Insert the fixings one in each direction through the mullion and bracket and secure with the lock nuts upon alignment of the mullion.

Insert the glide strips (2) fully into the back plate (1).

Mullion not shown for clarity.

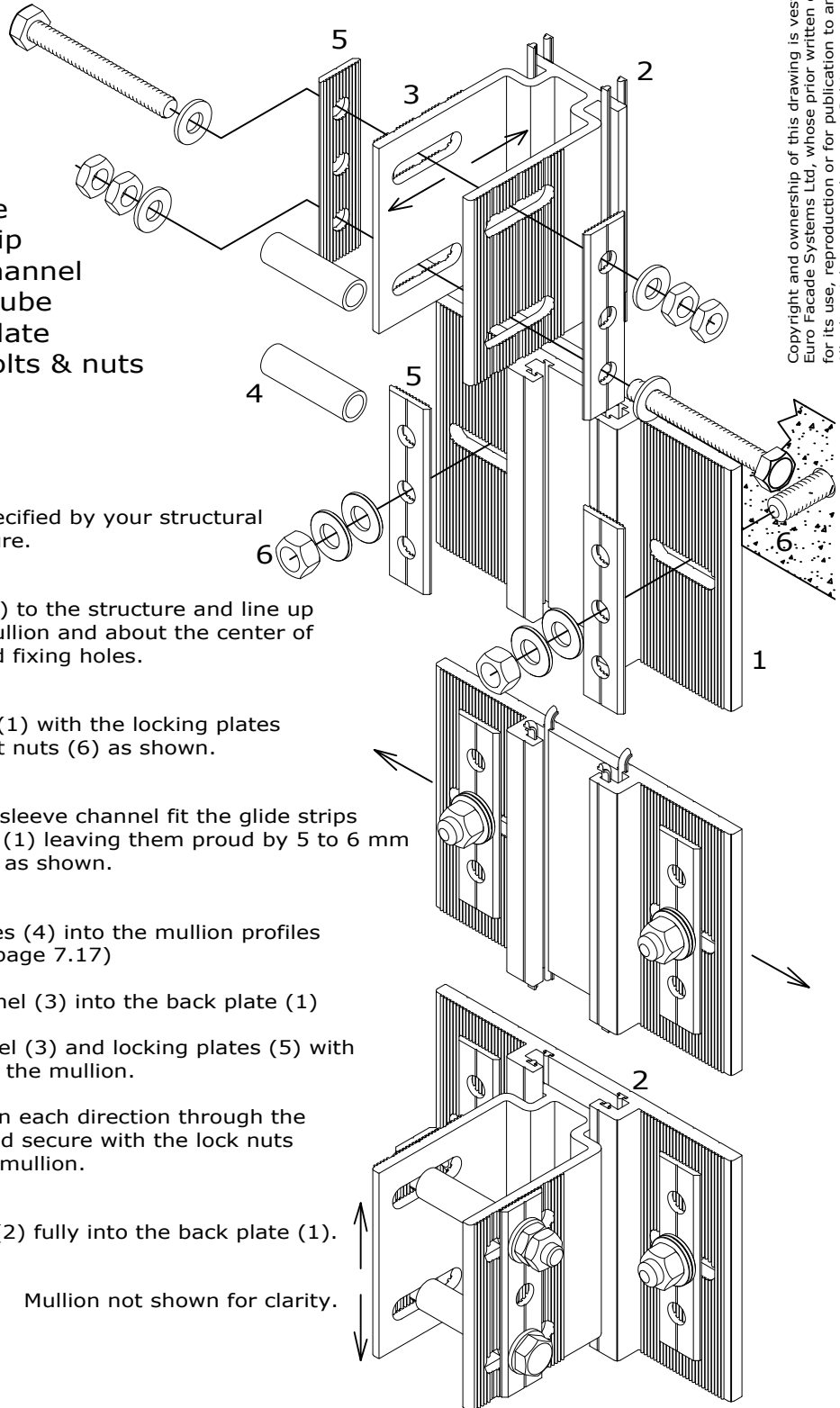

Copyright and ownership of this drawing is vested in EFT, Euro Facade Systems Ltd, whose prior written consent is required for its use, reproduction or for publication to any third party. All other rights reserved.



Fixing bracket instructions

Page 2

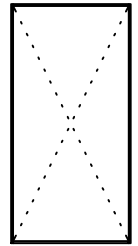

7.13

Copyright and ownership of this drawing is vested in EFT, Euro Facade Systems Ltd, whose prior written consent is required for its use, reproduction or for publication to any third party. All other rights reserved. Subject to modifications.

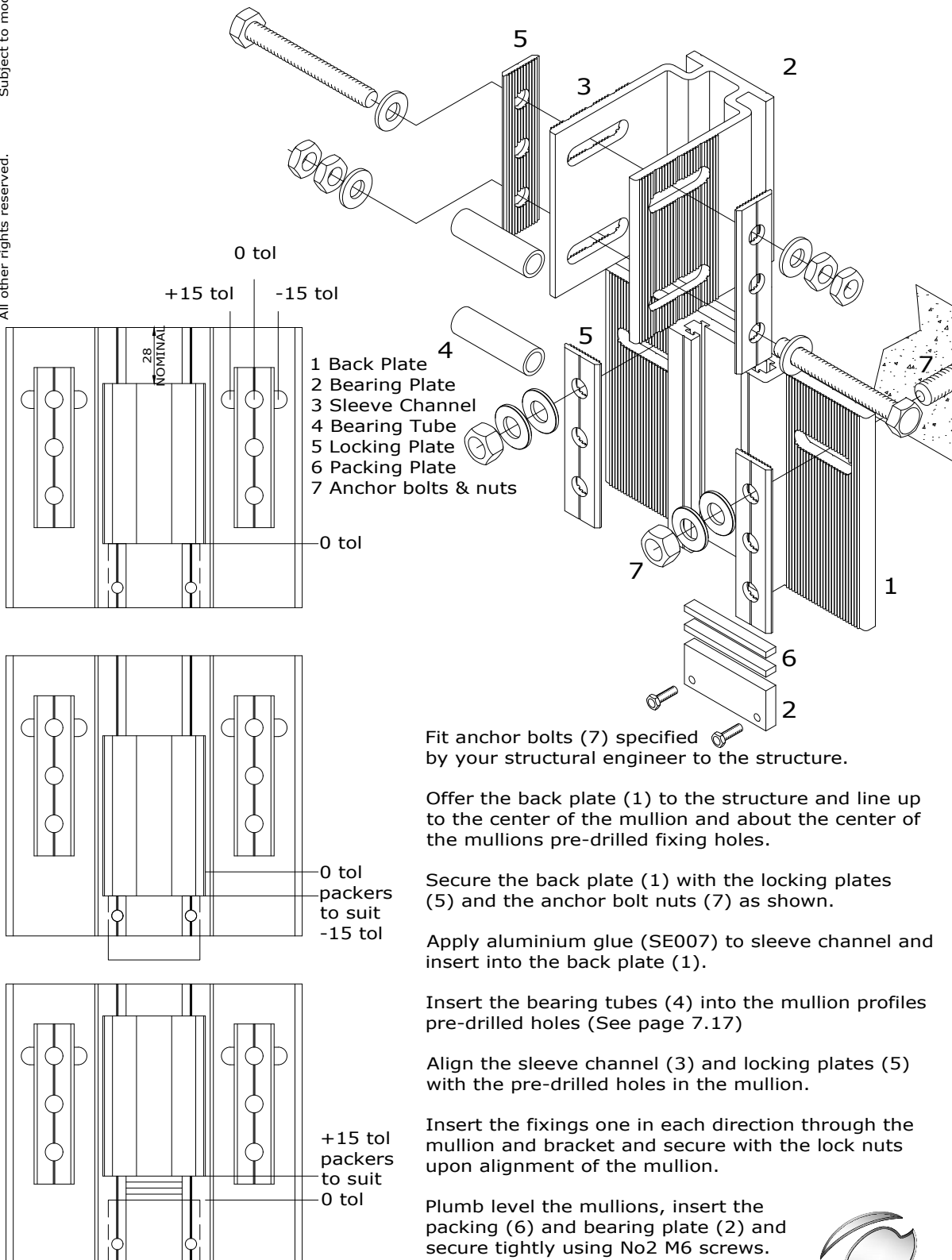

Fit anchor bolts (7) specified by your structural engineer to the structure.

Offer the back plate (1) to the structure and line up to the center of the mullion and about the center of the mullions pre-drilled fixing holes.

Secure the back plate (1) with the locking plates (5) and the anchor bolt nuts (7) as shown.

Apply aluminium glue (SE007) to sleeve channel and insert into the back plate (1).

Insert the bearing tubes (4) into the mullion profiles pre-drilled holes (See page 7.17)

Align the sleeve channel (3) and locking plates (5) with the pre-drilled holes in the mullion.

Insert the fixings one in each direction through the mullion and bracket and secure with the lock nuts upon alignment of the mullion.

Plumb level the mullions, insert the packing (6) and bearing plate (2) and secure tightly using No2 M6 screws.

Changes reserved
Sous reserve de modifications
Änderungen vorbehalten

Issue: 05
Date: 10-16

Installation

7

Comar 6EFT

Wall fixing bracket (jamb) CW671 Page 1

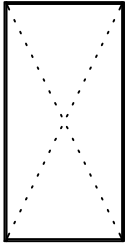

7.14

Fabricators Guide

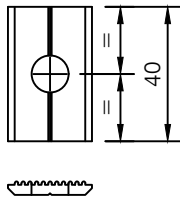
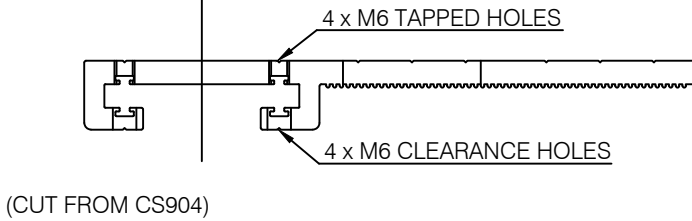
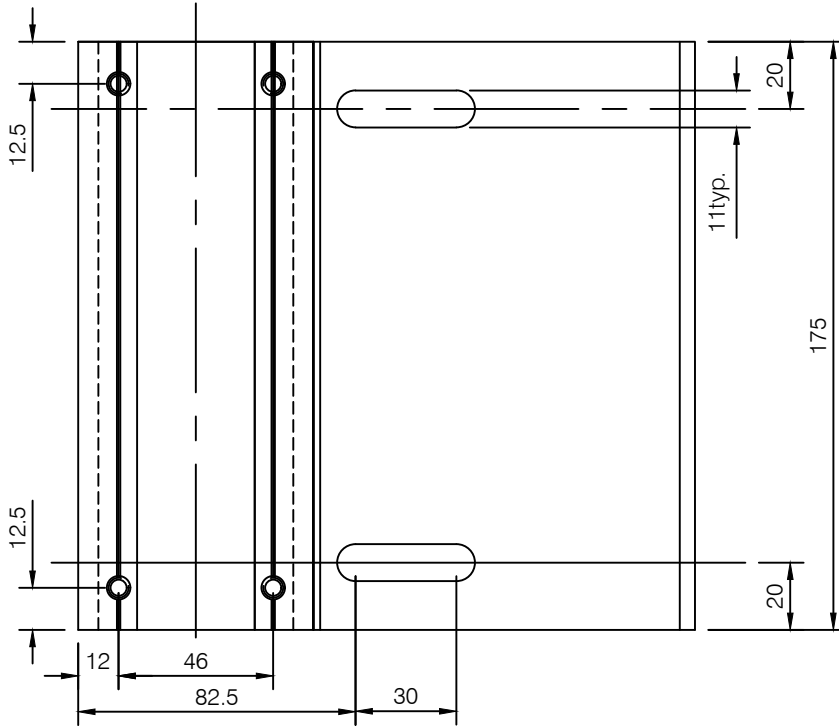

(CUT FROM CS903)

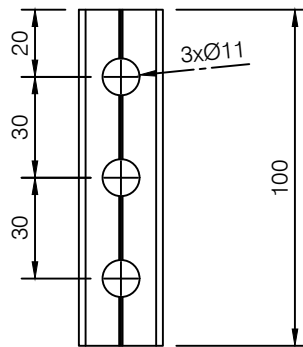

(CUT FROM CS903)



2 No. M6x20mm SCREWS
FX676XSLF

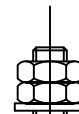

4 No. M10 Locking Nuts.
FX673XSLF

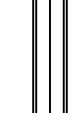

2 No. M10 x 90mm Hex Head Bolts.
FX672XSLF

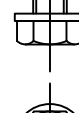

4 No. M10 Nylon Washers.
FX674XSLF



Changes reserved
Sous reserve de modifications
Änderungen vorbehalten

Wall fixing bracket instructions (jamb) CW671 Page 2

Copyright and ownership of this drawing is vested in EFT, Euro Facade Systems Ltd, whose prior written consent is required for its use, reproduction or for publication to any third party. All other rights reserved. Subject to modifications.

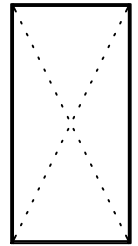

7.15

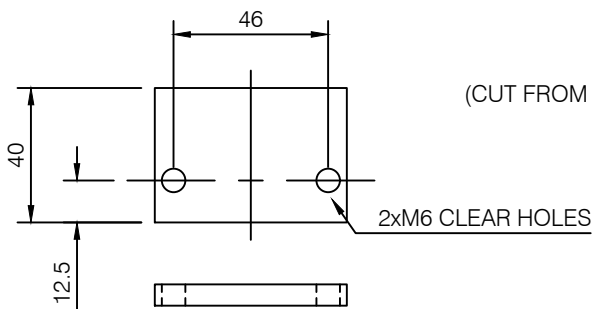
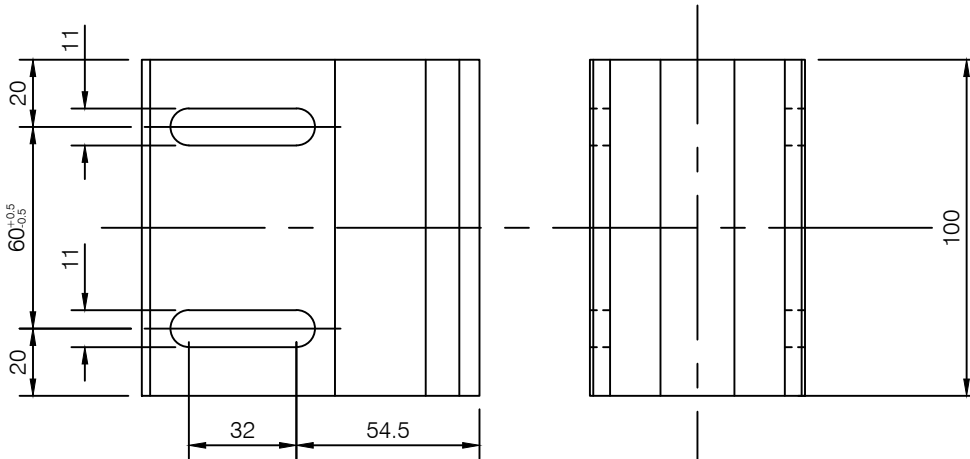

(CUT FROM CS902)

Aluminium glue to be applied before assembly (SE007)
Not supplied in kit.

1 No. 2 1/4" x 1/4" Aluminium Flat
CL006XSFLF

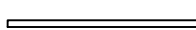
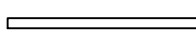
 2mm packer - CL012XSFLF (pack of 10)
 3mm packer - CL013XSFLF (pack of 10)

Packers are purchased as separate items.

2 No. Aluminium Tubes.
FX675XSFLF

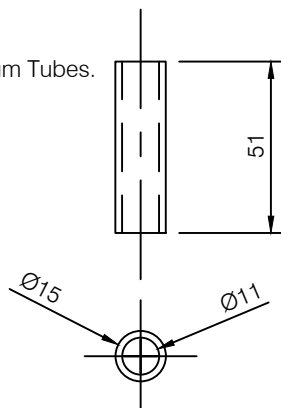

KIT COMPRISES

- 1 No. CS901 Component
- 1 No. CS902 Component
- 4 No. CS903 Components
- 1 No. Aluminium Flat. CL006XSFLF
- 2 No. Aluminium Tubes. FX675XSFLF
- 4 No. M10 Locking Nuts. FX673XSFLF
- 2 No. M10 x 90mm Hex Head Bolts. FX672XSFLF
- 4 No. M10 Nylon Washers. FX674XSFLF
- 2 No. M6 x 20mm Screws. FX676XSFLF

Changes reserved
Sous reserve de modifications
Änderungen vorbehalten

Issue: 05
Date: 10-16

Installation 7

Comar 6EFT

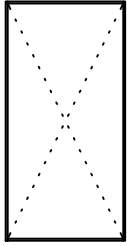

7.16

Wall fixing bracket
(intermediate) CW672
Page 1

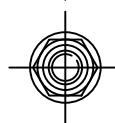
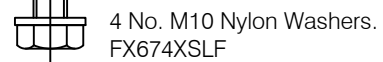
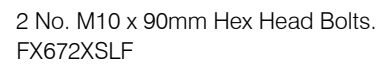
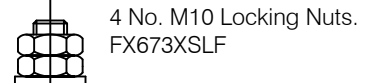
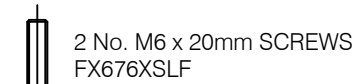
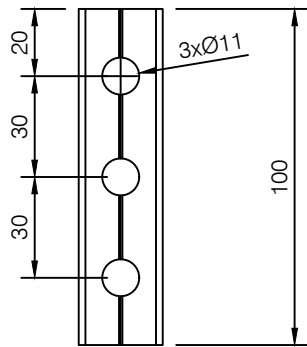
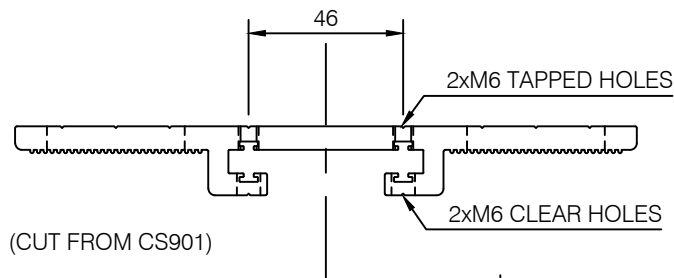
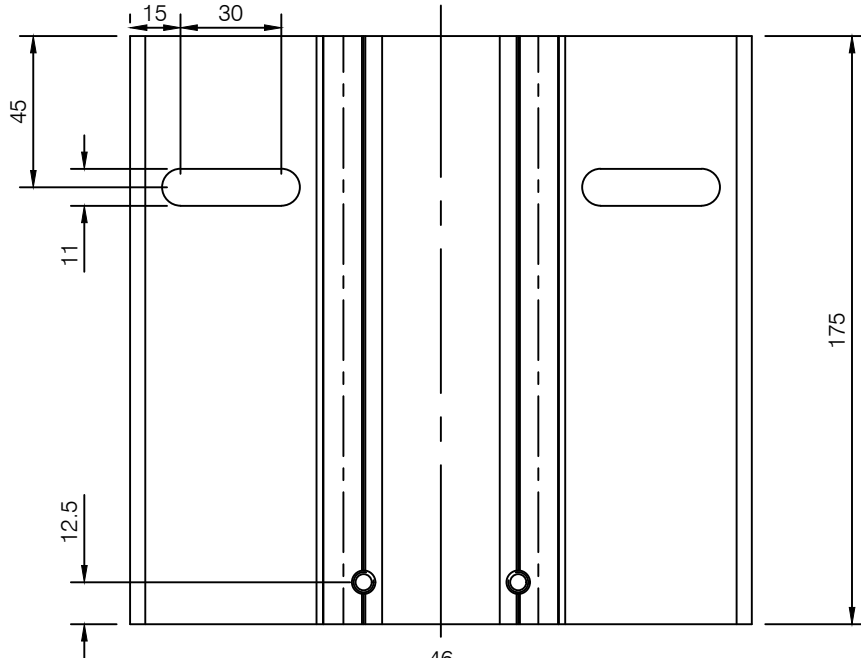

Changes reserved
Sous reserve de modifications
Änderungen vorbehalten

Copyright and ownership of this drawing is vested in EFT, Euro Facade Systems Ltd, whose prior written consent is required for its use, reproduction or for publication to any third party. All other rights reserved. Subject to modifications.

Wall fixing bracket instructions (intermediate) CW672 Page 2

Copyright and ownership of this drawing is vested in EFT, Euro Facade Systems Ltd, whose prior written consent is required for its use, reproduction or for publication to any third party. All other rights reserved. Subject to modifications.

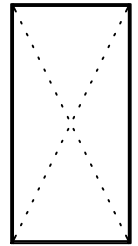

7.17

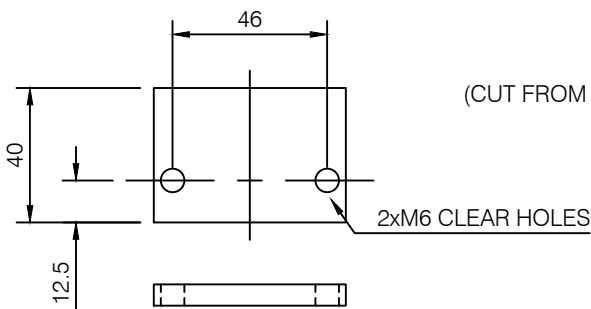
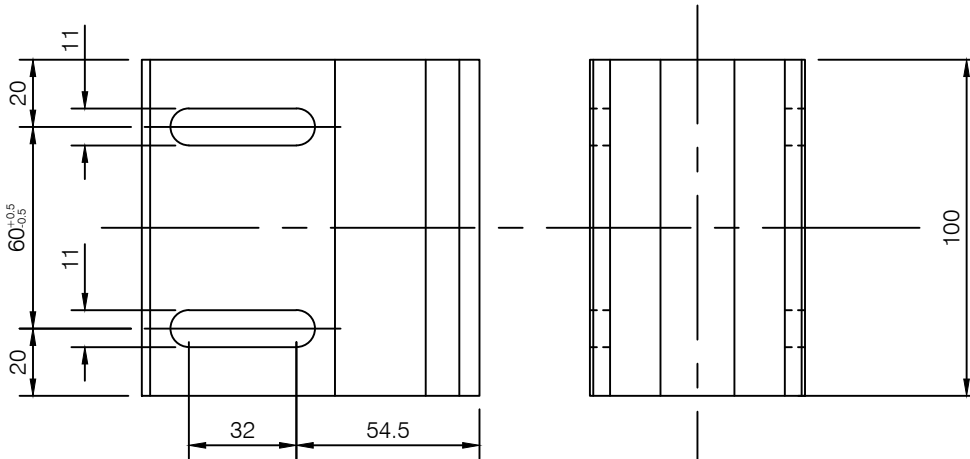

(CUT FROM CS902)

Aluminium glue to be applied before assembly (SE007)
Not supplied in kit.

1 No. 2 1/4" x 1/4" Aluminium Flat
CL006XSLF

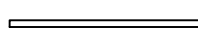
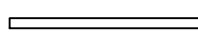
 2mm packer - CL012XSLF (pack of 10)
 3mm packer - CL013XSLF (pack of 10)

Packers are purchased as separate items.

2 No. Aluminium Tubes.
FX675XSLF

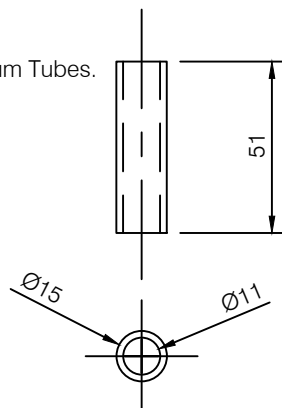

KIT COMPRISES

- 1 No. CS901 Component
- 1 No. CS902 Component
- 4 No. CS903 Components
- 1 No. Aluminium Flat. CL006XSLF
- 2 No. Aluminium Tubes. FX675XSLF
- 4 No. M10 Locking Nuts. FX673XSLF
- 2 No. M10 x 90mm Hex Head Bolts. FX672XSLF
- 4 No. M10 Nylon Washers. FX674XSLF
- 2 No. M6 x 20mm Screws. FX676XSLF

Changes reserved
Sous reserve de modifications
Änderungen vorbehalten

Issue: 05
Date: 10-16

Installation

7

Comar 6EFT

Wall sliding bracket (jamb) CW673 Page 1

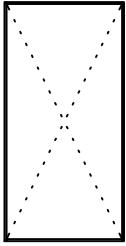

7.18

Fabricators Guide

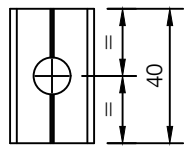
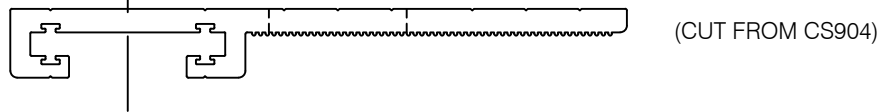
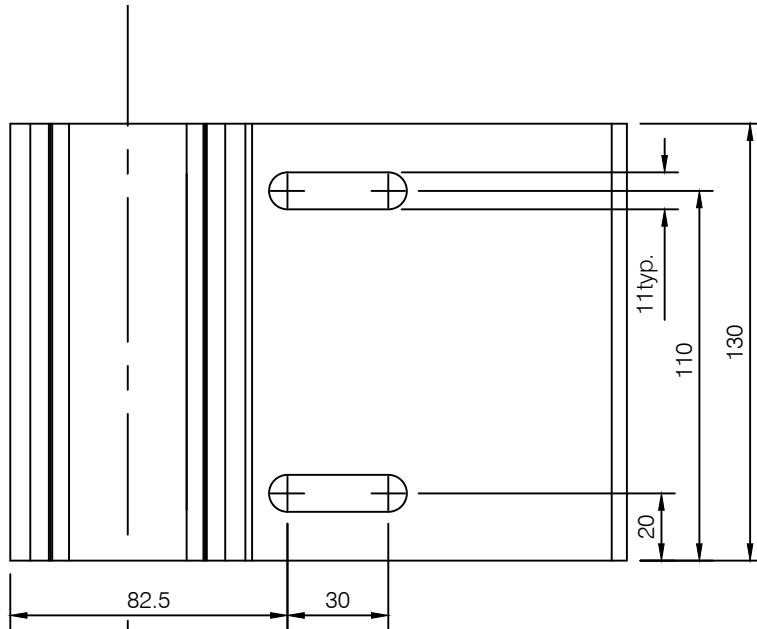

(CUT FROM CS903)

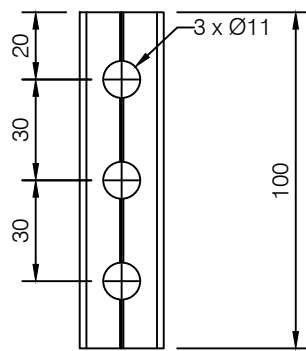

(CUT FROM CS903)

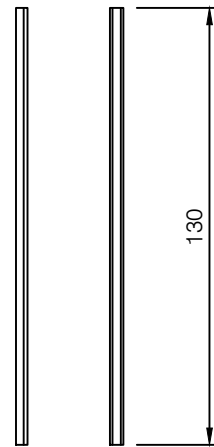

4 No. Req'd cut from GK055.
These items are not supplied in the kit.

Copyright and ownership of this drawing is vested in EFT, Euro Facade Systems Ltd, whose prior written consent is required for its use, reproduction or for publication to any third party. All other rights reserved. Subject to modifications.

Wall fixing bracket (jamb) CW673

Page 2

Comar 6EFT

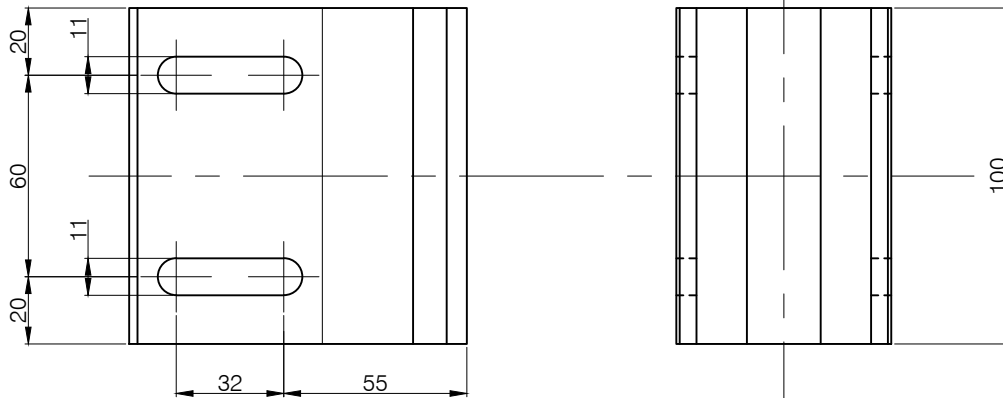
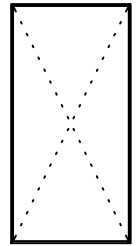

7.19

(CUT FROM CS902)

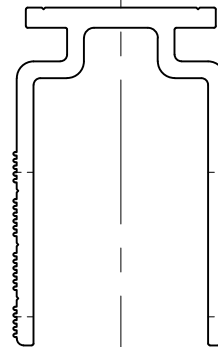

Fabricators Guide

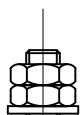

4 No. M10 Locking Nuts.
FX673XSLF

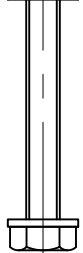

2 No. M10 x 90mm Hex Head Bolts.
FX672XSLF

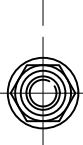

4 No. M10 Nylon Washers.
FX674XSLF

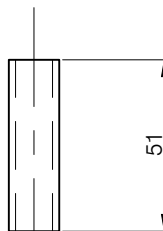

2 No. Aluminium Tubes.
FX675XSLF

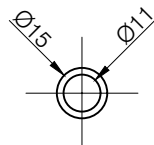

KIT COMPRISES

- 1 No. CS901 Component
- 1 No. CS902 Component
- 4 No. CS903 Components
- 2 No. Aluminium Tubes. FX675XSLF
- 4 No. M10 Locking Nuts. FX673XSLF
- 2 No. M10 x 90mm Hex Head Bolts. FX672XSLF
- 4 No. M10 Nylon Washers. FX674XSLF

Changes reserved
Sous reserve de modifications
Änderungen vorbehalten

Issue: 05
Date: 10-16

Installation

7

Comar 6EFT

Wall sliding bracket (intermediate) CW674 Page 1

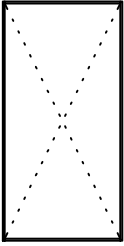

7.20

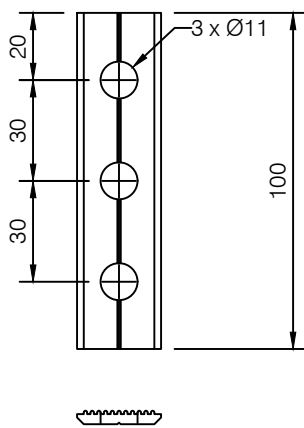
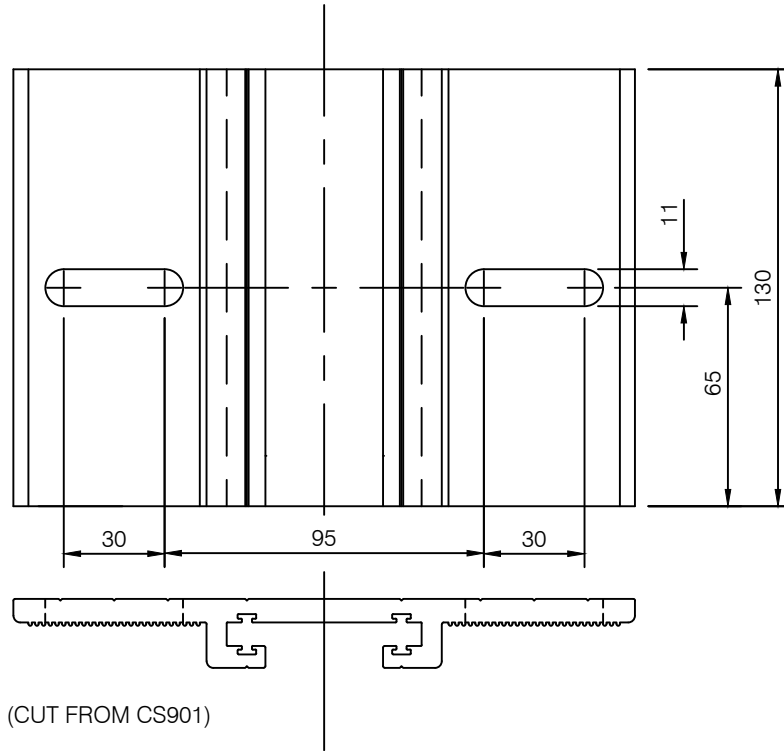

(CUT FROM CS903)

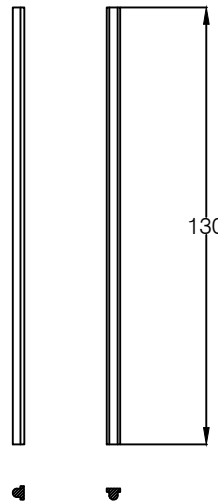

4 No. Req'd cut from GK055.
These items are not supplied in the kit.

Copyright and ownership of this drawing is vested in EFT, Euro Facade Systems Ltd, whose prior written consent is required for its use, reproduction or for publication to any third party. All other rights reserved. Subject to modifications.

Fabricators Guide

7

Installation

Comar 6EFT

Wall fixing bracket (intermediate) CW674 Page 2

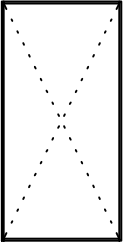

7.21

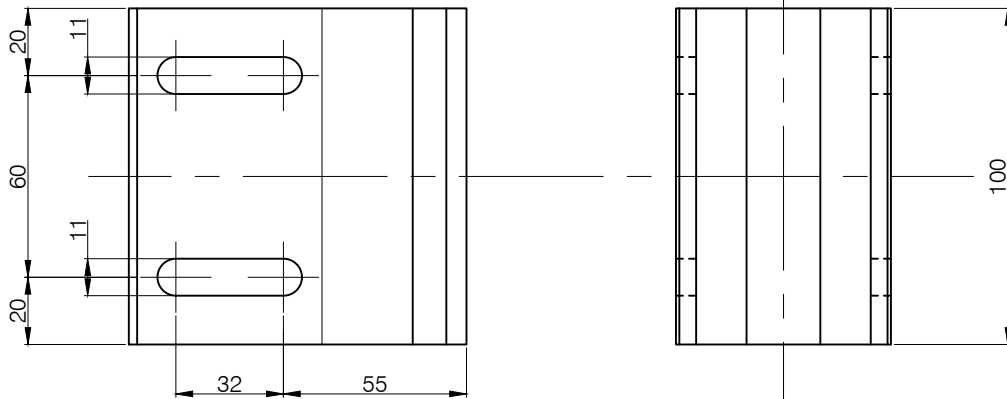

(CUT FROM CS902)

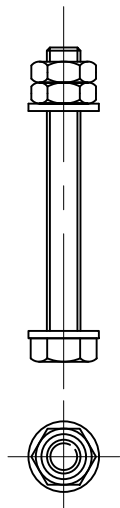
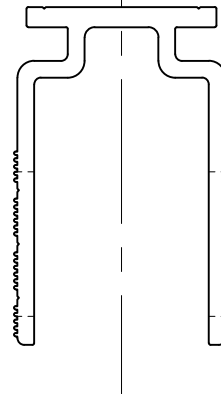

4 No. M10 Locking Nuts.
FX673XSLF

2 No. M10 x 90mm Hex Head Bolts.
FX672XSLF

4 No. M10 Nylon Washers.
FX674XSLF

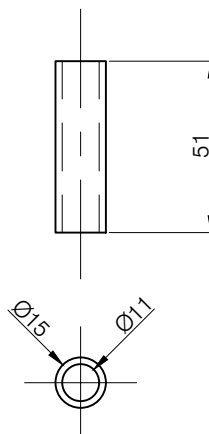

2 No. Aluminium Tubes.
FX675XSLF

KIT COMPRISES

- 1 No. CS901 Component
- 1 No. CS902 Component
- 4 No. CS903 Components
- 2 No. Aluminium Tubes. FX675XSLF
- 4 No. M10 Locking Nuts. FX673XSLF
- 2 No. M10 x 90mm Hex Head Bolts. FX672XSLF
- 4 No. M10 Nylon Washers. FX674XSLF

Changes reserved
Sous reserve de modifications
Änderungen vorbehalten

Issue: 05
Date: 10-16

Profile Sections

7

Comar 6EFT

Direct fix to steel
fixing lug preparation

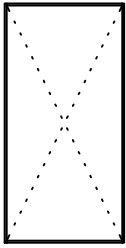

7.22

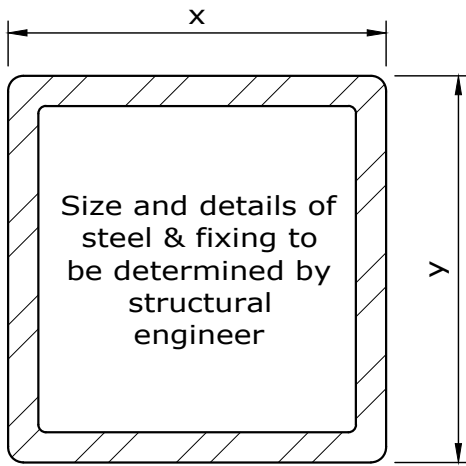

Aluminium to steel isolator
(supplied by others)

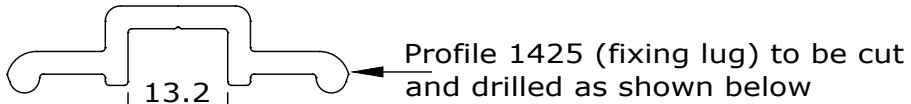

1mm spring washer
(supplied by others)

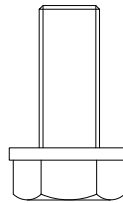

Fixing bolt (supplied by others) to
structural engineers specification

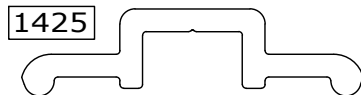

Profile 1425 to be cut and drilled
to create fixing lugs as shown

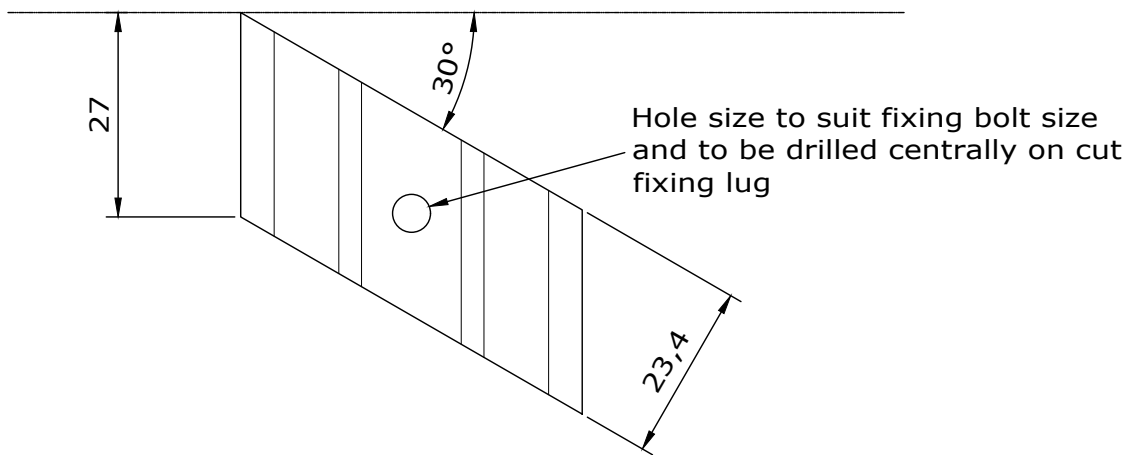

Copyright and ownership of this drawing is vested in EFT,
Euro Facade Systems Ltd, whose prior written consent is required
for its use, reproduction or for publication to any third party.
All other rights reserved. Subject to modifications.

Fabricators Guide



comar
ARCHITECTURAL ALUMINIUM SYSTEMS

Changes reserved
Sous reserve de modifications
Änderungen vorbehalten

Issue: 05
Date : 10-16

Direct fix to steel Fixing lug spacing

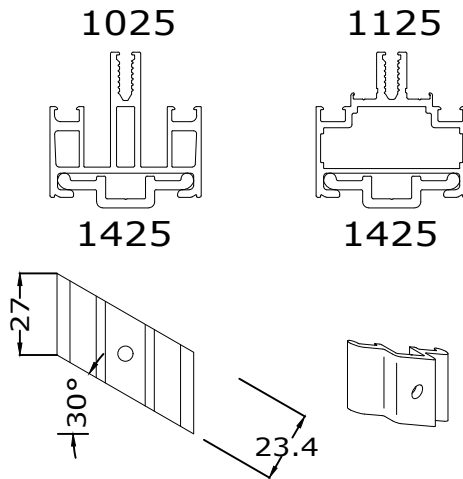

Centre of fixing lug to be positioned 100mm from the end of each mullion and transom.

Fixing lug spacing then depends on height of curtain walling.

Areas of curtain walling	
≤15m in height	>15m in height
Fixing lugs at 600mm centres max.	Fixing lugs at 400mm centres max.

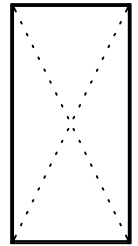

7.23

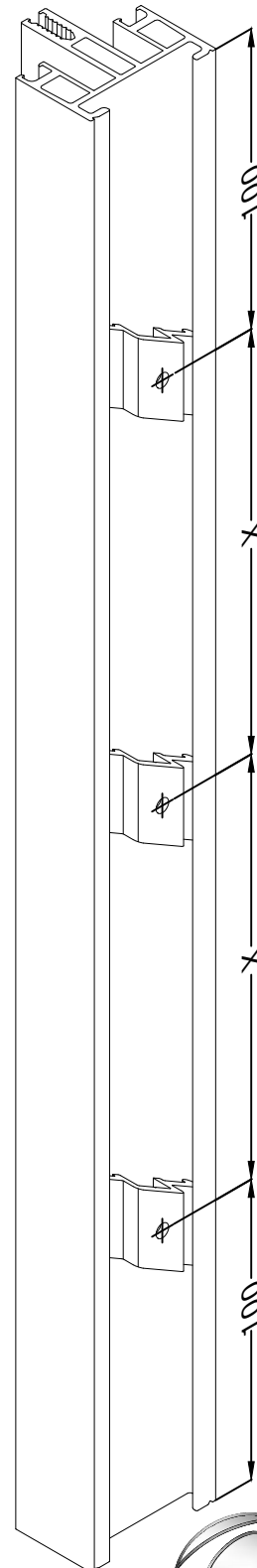

Fabricators Guide

Installation

7

Comar 6EFT

Direct fix to steel Fixing lugs

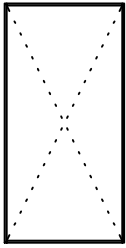

7.24

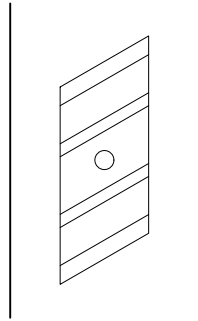

1. Aluminium to steel separator, fixing lug and 1mm spring washer to be fixed to steel using suitable fixing as approved by structural engineer at spacing as stated on page 7.28.

2. Mullion/transom profile to be placed over toggles.

3. Toggle to be twisted through 90°

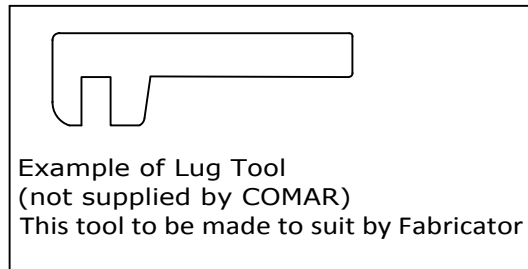

4. Toggle in final position

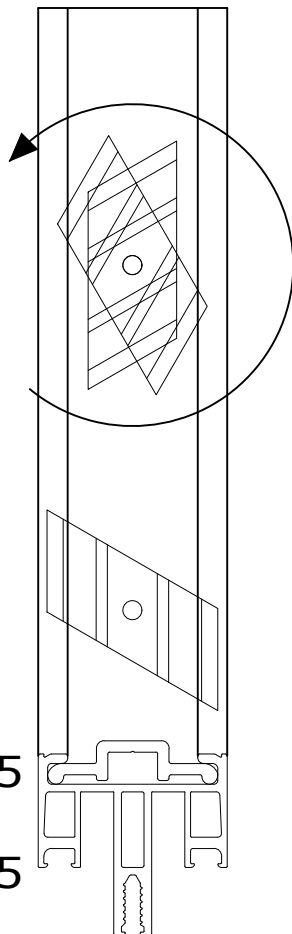

Fabricators Guide

Copyright and ownership of this drawing is vested in EFT, Euro Facade Systems Ltd, whose prior written consent is required for its use, reproduction or for publication to any third party. All other rights reserved. Subject to modifications.

Copyright and ownership of this drawing is vested in EFT, Euro Facade Systems Ltd, whose prior written consent is required for its use, reproduction or for publication to any third party. All other rights reserved.

Direct fix to steel Internal sealing

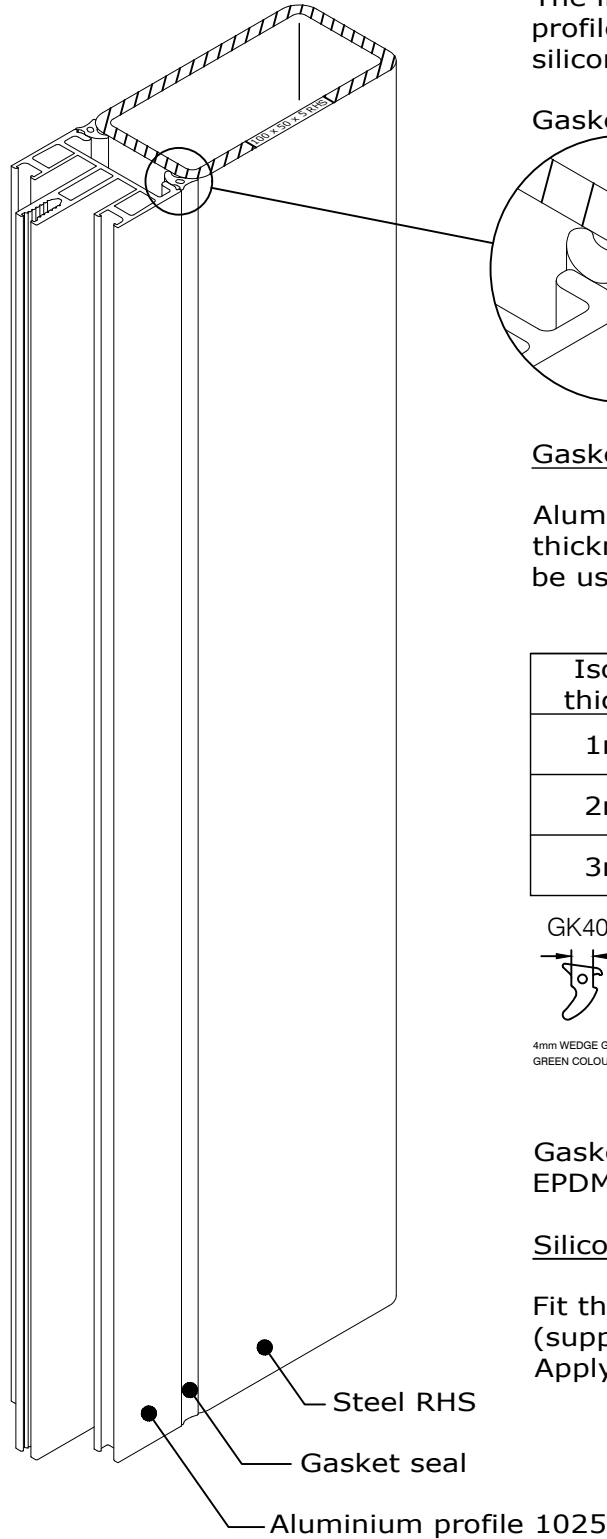

7 Installation

Comar 6EFT

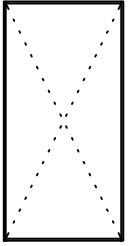

The internal seal between the aluminium profile and the steel can be a gasket or silicone sealant.

Gasket seal

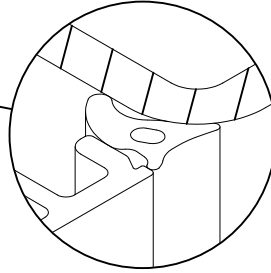

Silicone seal

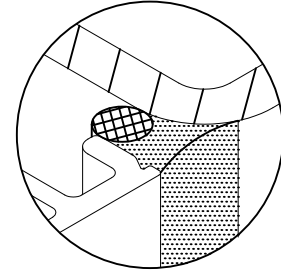

or

7.25

Gasket seal

Aluminium to steel isolator thickness will affect which gasket should be used.

Isolator thickness	Gasket to use	Wedge size
1mm	GK405	4mm
2mm	GK407	5mm
3mm	GK408	6mm



4mm WEDGE GASKET
GREEN COLOUR STRIP



5.2mm WEDGE GASKET
BROWN COLOUR STRIP

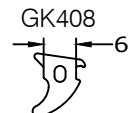

6mm WEDGE GASKET
PINK COLOUR STRIP

Gasket joints to be bonded using EPDM bonding compound.

Silicone seal

Fit the backing rods as shown.
(supplied by others)
Apply the silicone sealant as shown.

Changes reserved
Sous reserve de modifications
Änderungen vorbehalten

Issue: 05
Date: 10-16

Installation

7

Comar 6EFT

Installation methods

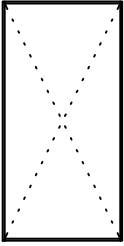

Installation Method: 1

Mullions followed by transoms.

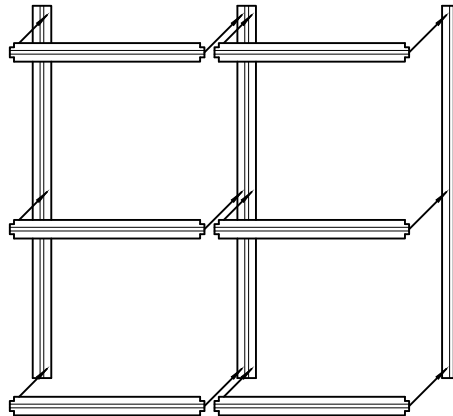

7.26

Installation Method: 2

Elements (ladders) followed by intermediate transoms.

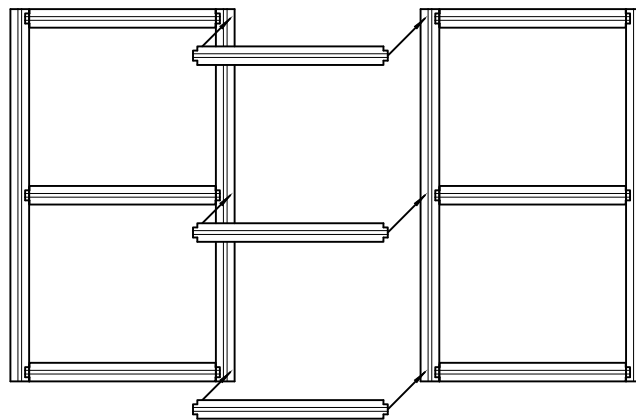

Copyright and ownership of this drawing is vested in EFT, Euro Facade Systems Ltd, whose prior written consent is required for its use, reproduction or for publication to any third party. All other rights reserved. Subject to modifications.

Split mullion details

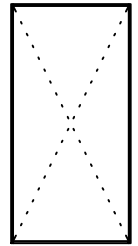
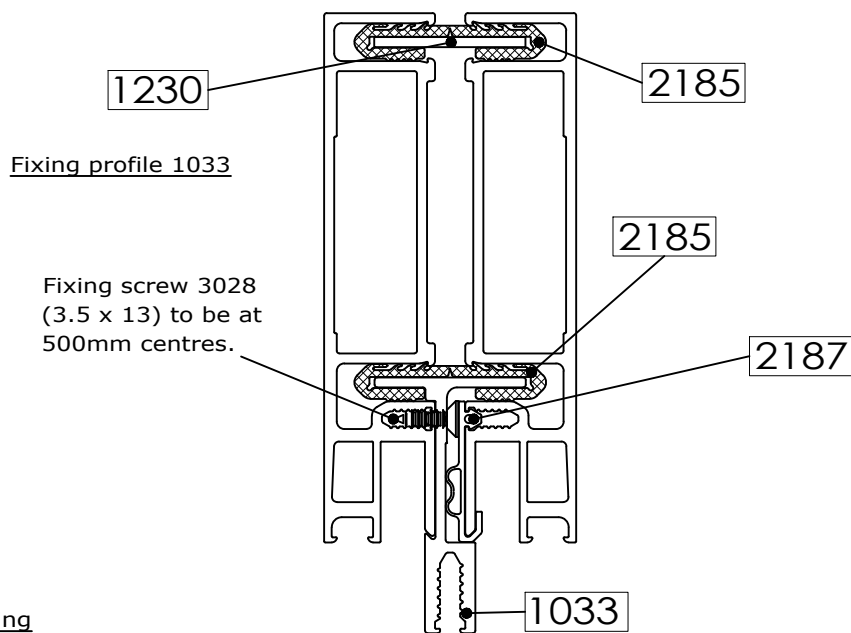

7.27

Mullion-transom fixing

For split mullions, either spring loaded cleats (2310) or precut transom cleats can be used to fix to the mullions.

Note: With spring loaded cleat 2310, the 45mm transom cannot be used with a split mullion.

Drainage diverter installation (for split mullions only)

Where a drainage diverter should be installed according to page 7.37, opposite sides of the drainage diverter must be cut away and positioned at 2 different transom levels.

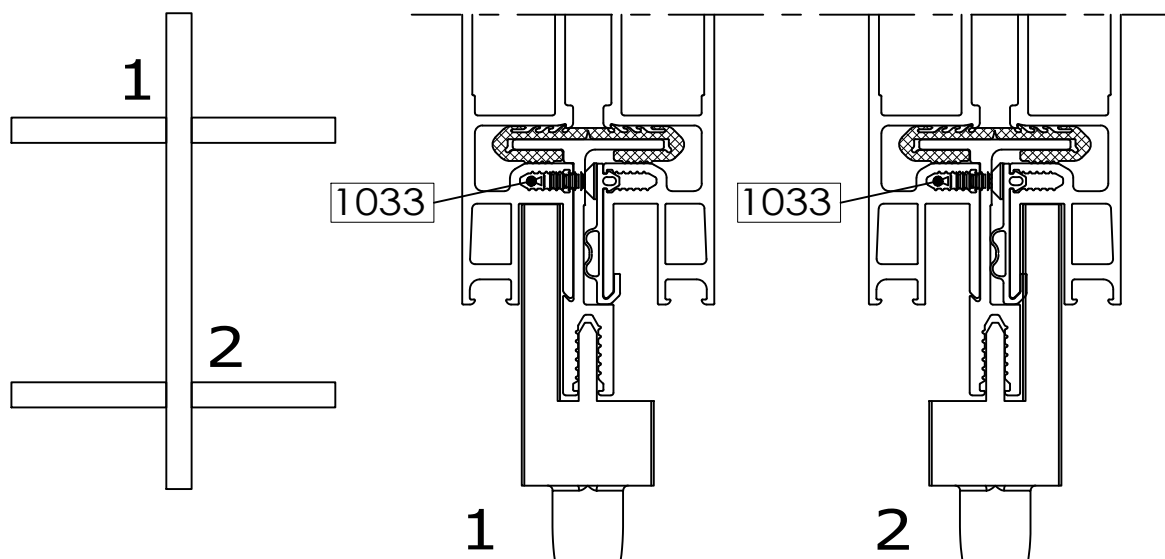

Installation

7

Comar 6EFT

Mullion - Transom connection (Option 1)

Notes:

1. Apply sealant to transom fixing screws and gasket groove below transom seal.
2. Apply sealant into glazing groove and fit corner mouldings.
3. Apply sealant to gasket ends and bring together.

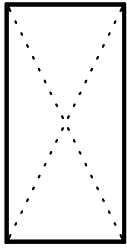

7.28

Fabricators Guide

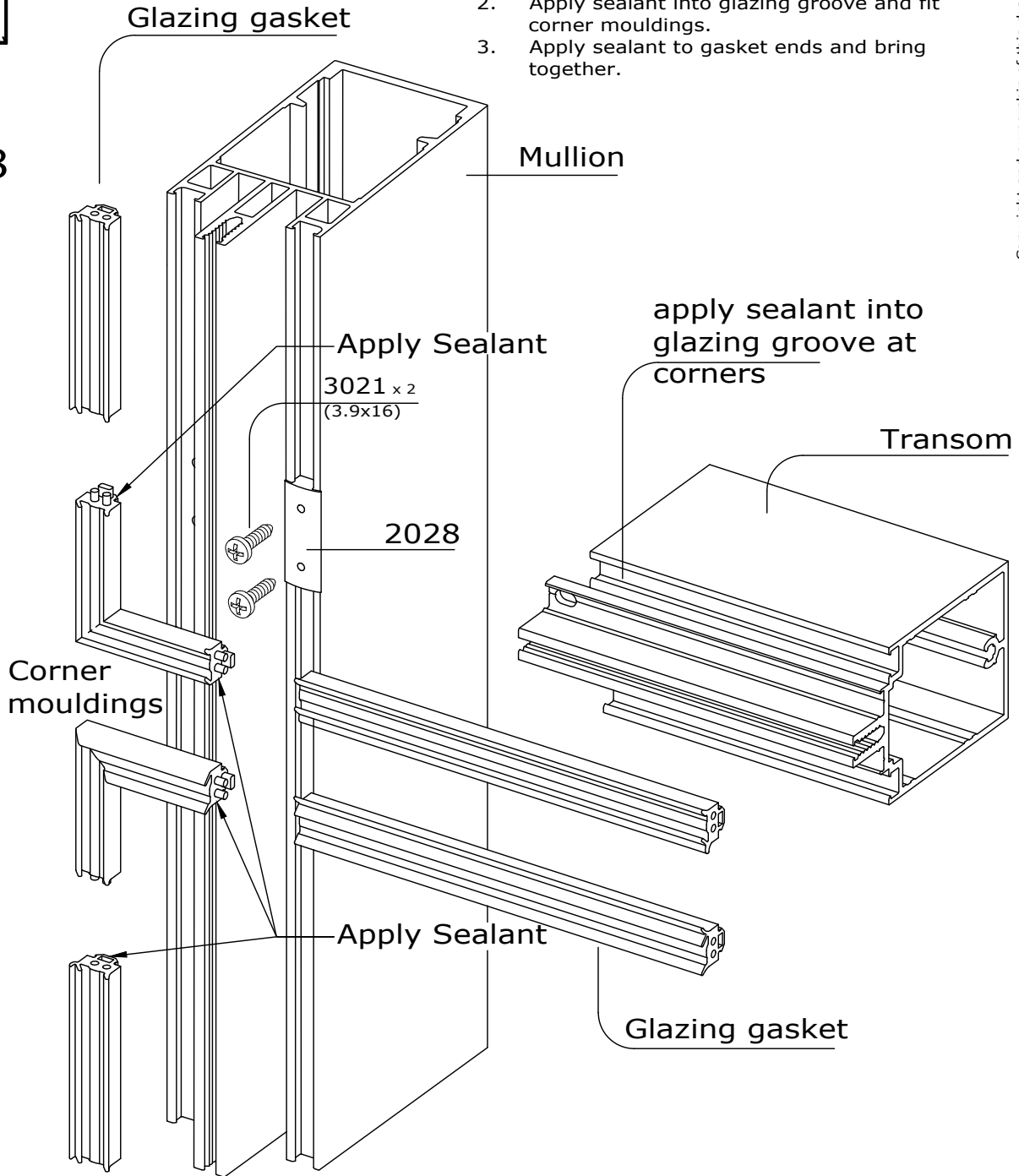

Copyright and ownership of this drawing is vested in EFT, Euro Facade Systems Ltd, whose prior written consent is required for its use, reproduction or for publication to any third party. All other rights reserved. Subject to modifications.



comar
ARCHITECTURAL ALUMINIUM SYSTEMS

Changes reserved
Sous reserve de modifications
Änderungen vorbehalten

Issue: 05
Date : 10-16

Mullion - Transom connection (Option 2)

Comar 6EFT

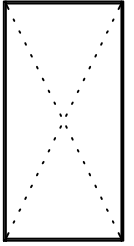

(with spring loaded transom cleat)

Notes:

1. Apply sealant to transom fixing screws and gasket groove below transom seal.
2. Apply sealant into glazing groove and fit corner mouldings.
3. Apply sealant to gasket ends and bring together.
4. Glue spring cleat 2310 into position.

7.29

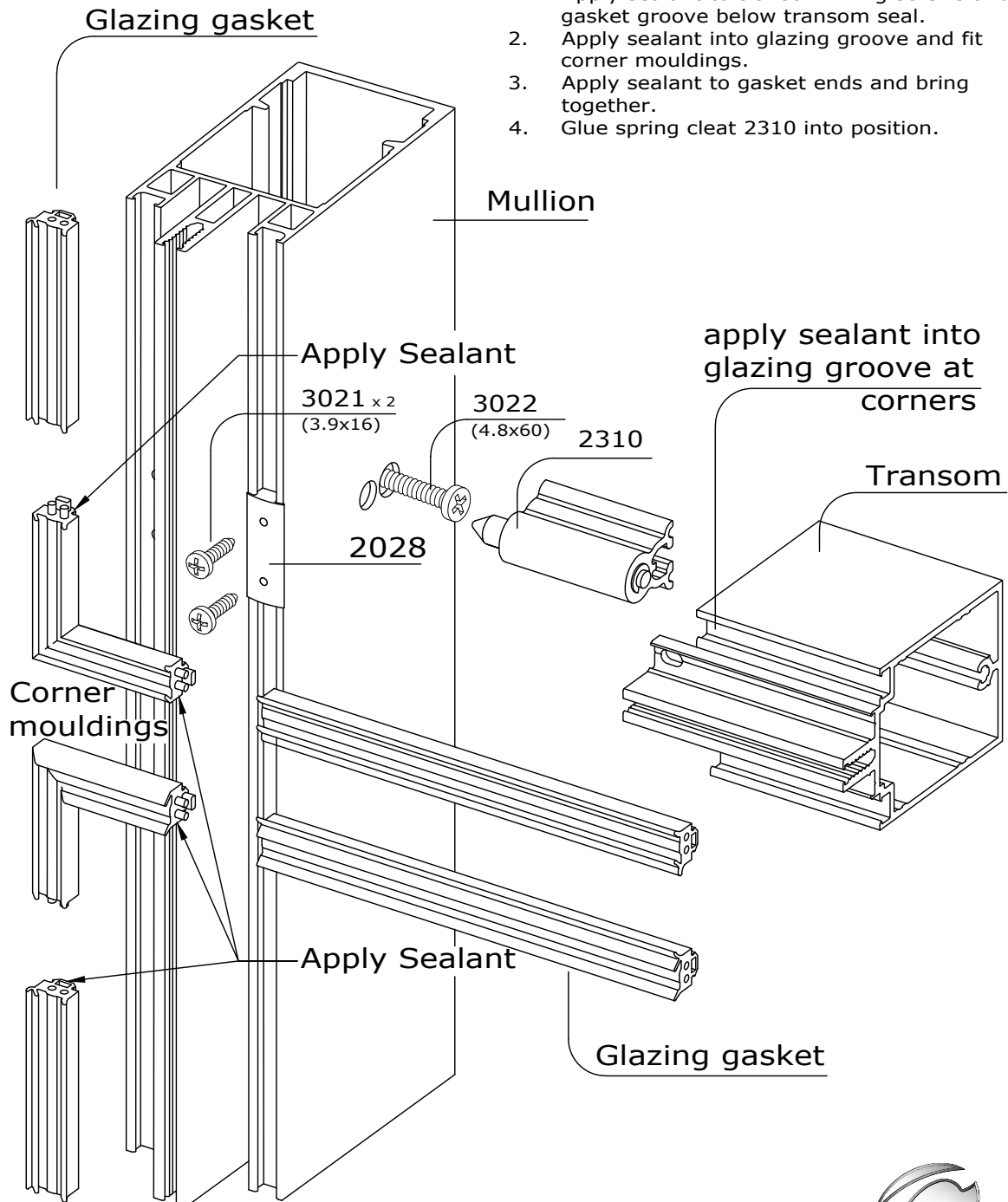

Installation

7

Comar 6EFT

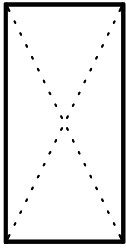

Mullion - Transom connection (Option 3)

(for making ladder units)

(for transoms installed between mullions or ladders)

Notes:

1. Apply sealant to transom fixing screws and gasket groove below transom seal.
2. Apply sealant into glazing groove and fit corner mouldings.
3. Apply sealant to gasket ends and bring together.

Fabricators Guide

7.30

Glazing gasket

Mullion

Apply Sealant

3022 (4.8 x 60) (for ladder unit only)

3021 x 2
(3.9x16)

Pre cut cleat from profile 1300

(Pre-cut & drilled cleats available for 85mm transom & above only, for other transom sizes or faceted joints, cleat must be cut)

3025 x 4 (4.8 x 13)

Transom

2028

Corner mouldings

Apply Sealant

apply sealant into glazing groove at corners

Glazing gasket



comar

ARCHITECTURAL ALUMINIUM SYSTEMS

Changes reserved
Sous reserve de modifications
Änderungen vorbehalten

Issue: 05
Date : 10-16

Copyright and ownership of this drawing is vested in EFT, Euro Facade Systems Ltd, whose prior written consent is required for its use, reproduction or for publication to any third party. All other rights reserved. Subject to modifications.

Mullion - Transom Connection (Option 4) (Direct fix to steel or timber)

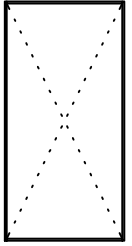

Notes:

1. Apply sealant to transom fixing screws and gasket groove below transom seal.
2. Apply sealant into glazing groove and fit corner mouldings.
3. Apply sealant to gasket ends and bring together.

7.31

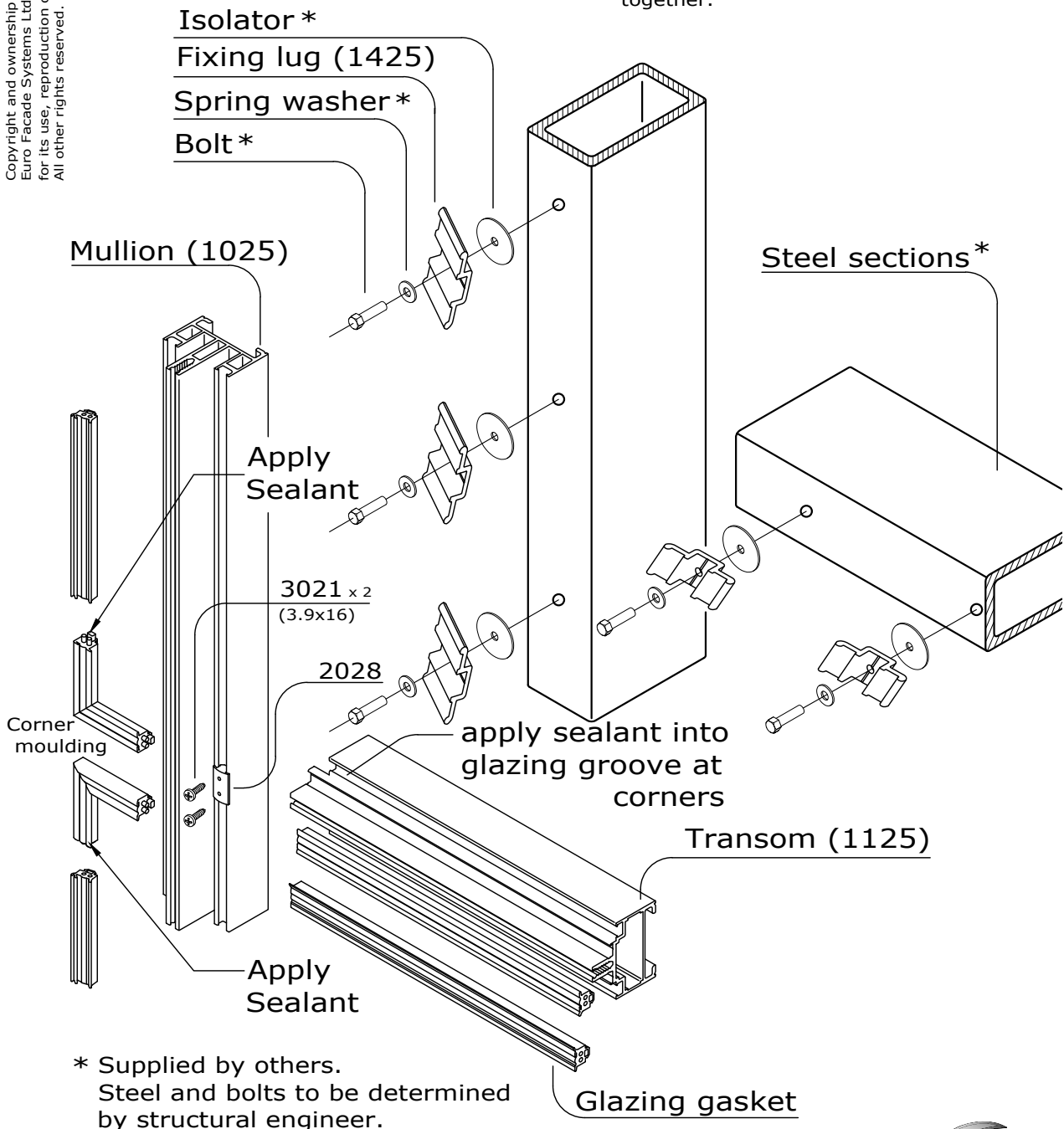

* Supplied by others.
Steel and bolts to be determined
by structural engineer.

Changes reserved
Sous reserve de modifications
Änderungen vorbehalten

Issue: 05
Date: 10-16

Installation

7

Comar 6EFT

Heavy glass support Connection (Option 5)

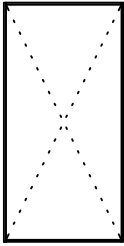

7.32

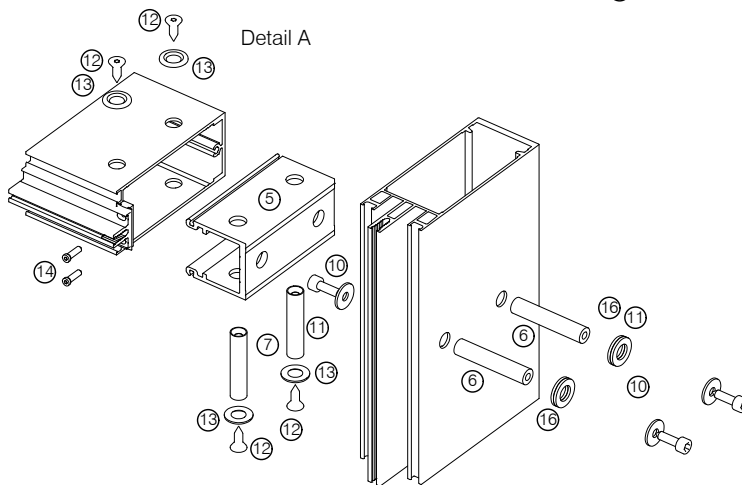
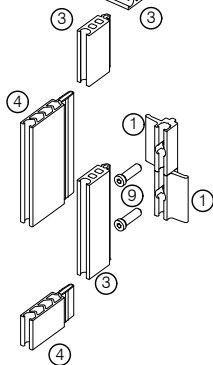
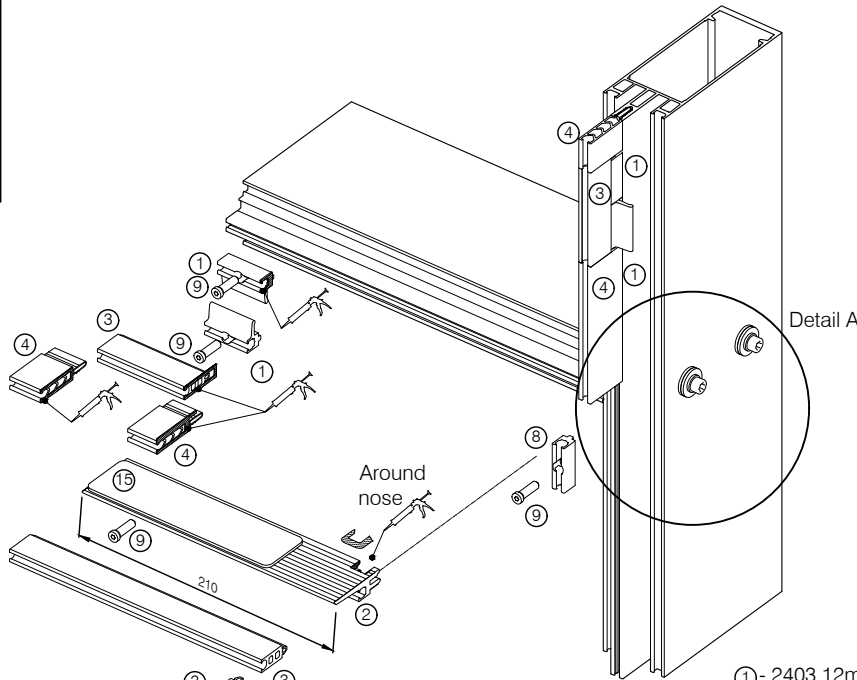

- ① - 2403 12mm double glazing clamp
- ② - 140x series 12mm glass setting block
- ③ - 2155 22mm extension gasket
- ④ - 2203 34mm thermal break
- ⑤ - 1305 transom cleat
- ⑥ - 1891 11x3 59.5mm aluminium tube
- ⑦ - 1890 11x3 50mm aluminium tube
- ⑧ - 2409 setting block support
- ⑨ - 3029 5.5x23mm special screw
- ⑩ - 3004 5.5x19mm socketed screw
- ⑪ - 3095 M6 DIN9021SS washer
- ⑫ - 3017 5.5x16 countersink screw
- ⑬ - 3094 SS countersink washer
- ⑭ - 3021 3.9x16 special screw
- ⑮ - 150mm wide glass shims
- ⑯ - 3042 M12 SS washer

Copyright and ownership of this drawing is vested in EFT, Euro Facade Systems Ltd, whose prior written consent is required for its use, reproduction or for publication to any third party. All other rights reserved. Subject to modifications.



APPLY SEALANT TO ALL JOINTS

Fabricators Guide



comar
ARCHITECTURAL ALUMINIUM SYSTEMS

Changes reserved
Sous reserve de modifications
Änderungen vorbehalten

Issue: 05
Date : 10-16

Heavy glass support Connection (Option 5)

Copyright and ownership of this drawing is vested in EFT, Euro Facade Systems Ltd, whose prior written consent is required for its use, reproduction or for publication to any third party. All other rights reserved. Subject to modifications.

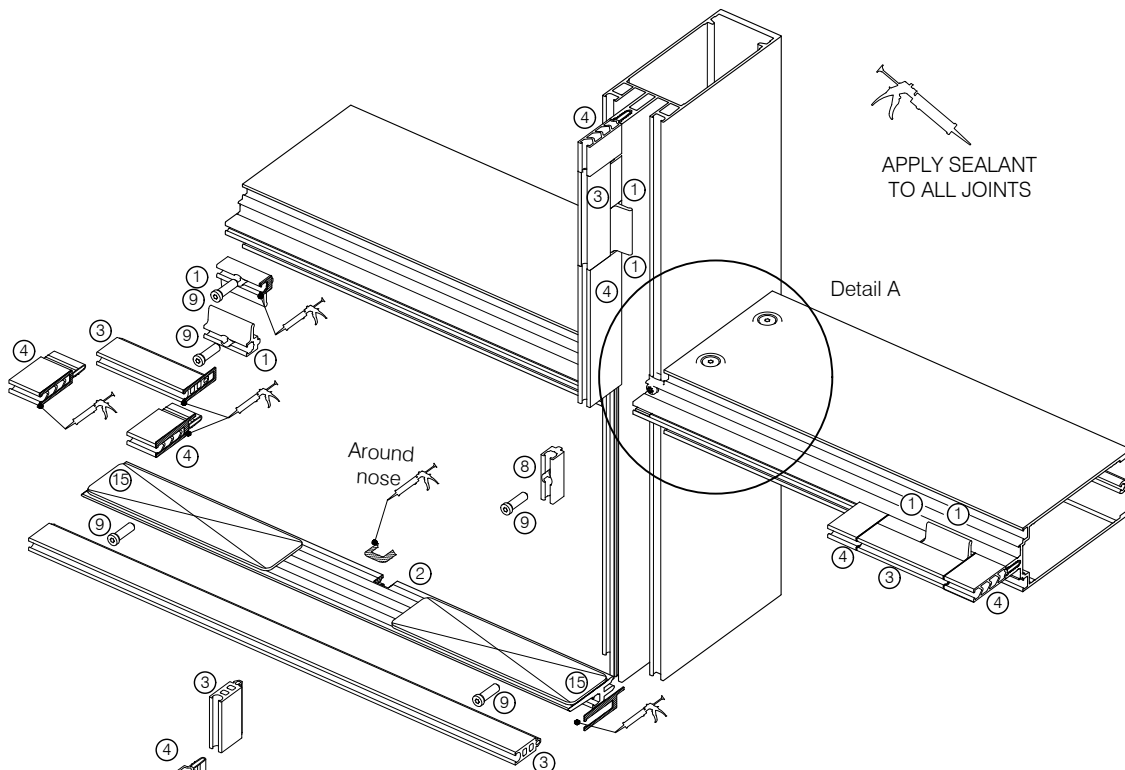

7.33

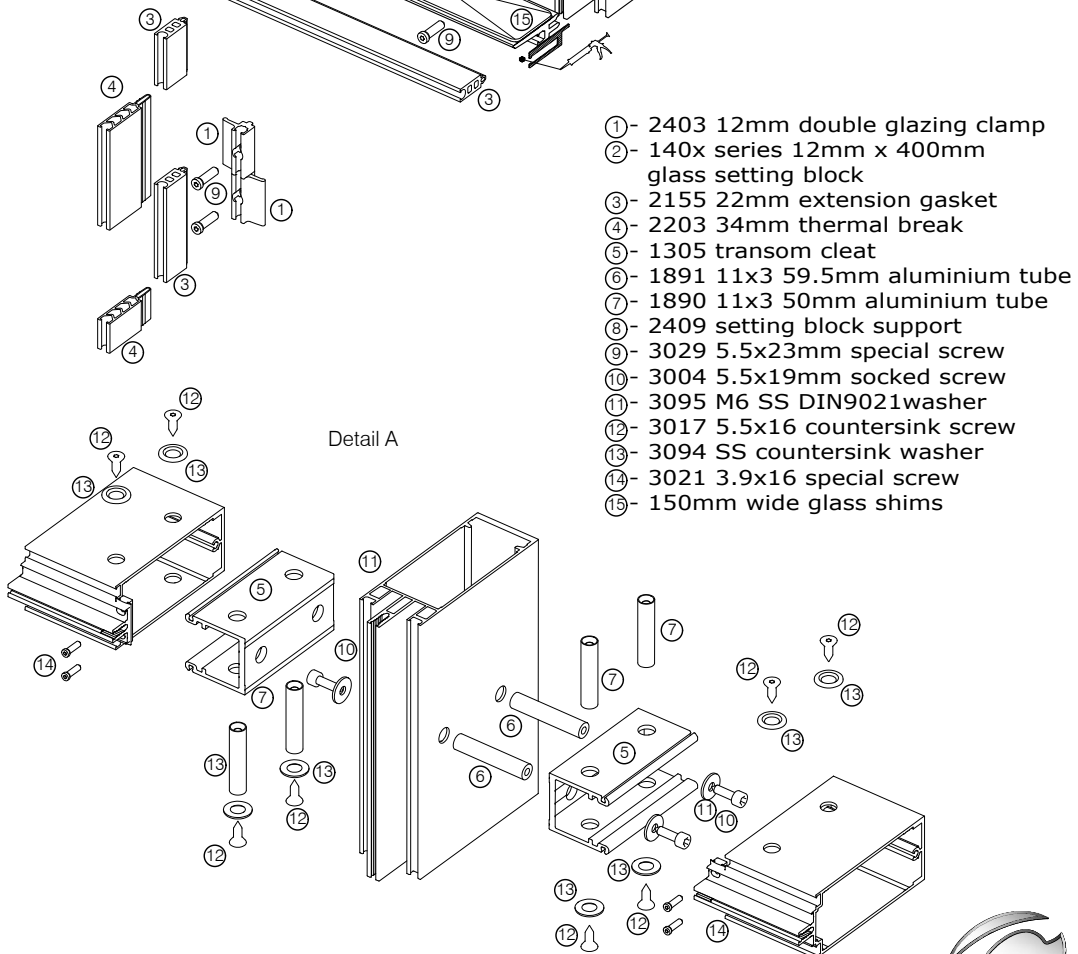

- ①- 2403 12mm double glazing clamp
- ②- 140x series 12mm x 400mm glass setting block
- ③- 2155 22mm extension gasket
- ④- 2203 34mm thermal break
- ⑤- 1305 transom cleat
- ⑥- 1891 11x3 59.5mm aluminium tube
- ⑦- 1890 11x3 50mm aluminium tube
- ⑧- 2409 setting block support
- ⑨- 3029 5.5x23mm special screw
- ⑩- 3004 5.5x19mm socked screw
- ⑪- 3095 M6 SS DIN9021 washer
- ⑫- 3017 5.5x16 countersink screw
- ⑬- 3094 SS countersink washer
- ⑭- 3021 3.9x16 special screw
- ⑮- 150mm wide glass shims

Changes reserved
Sous reserve de modifications
Änderungen vorbehalten

Issue: 05
Date: 10-16

Installation

7

Comar 6EFT

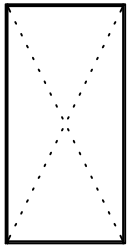

7.34

Fabricators Guide

Mullion-transom Connection options

Option 1

Screws EFT-3021

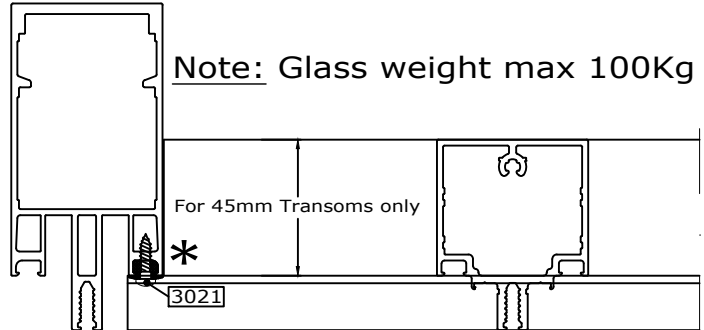

Ladders / units

Option 2

Spring loaded cleat EFT-2310
or
Screw EFT-3022

Tooling: Com6-EFT-Jig1

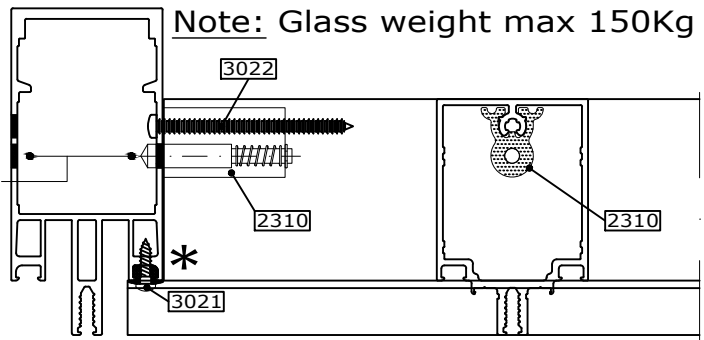

Option 3 or 3a

Precut & drill cleat profile EFT-1300 to length

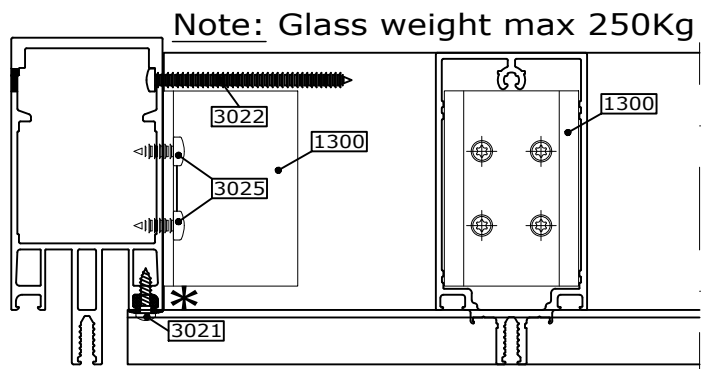

Option 4

For direct fix to steel details refer to drawings

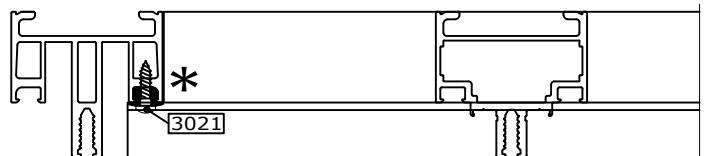

*

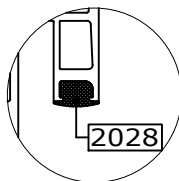

Transom seal EFT-2028 to be installed at each mullion-transom connection.

All screws to be sealed.

Copyright and ownership of this drawing is vested in EFT, Euro Facade Systems Ltd, whose prior written consent is required for its use, reproduction or for publication to any third party. All other rights reserved. Subject to modifications.

Copyright and ownership of this drawing is vested in EFT, Euro Facade Systems Ltd, whose prior written consent is required for its use, reproduction or for publication to any third party. All other rights reserved. Subject to modifications.

Mullion - Transom Connection

7

Installation Comar 6EFT

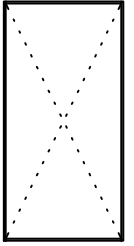

7.35

Option 5
Glass weight max. 450 kg

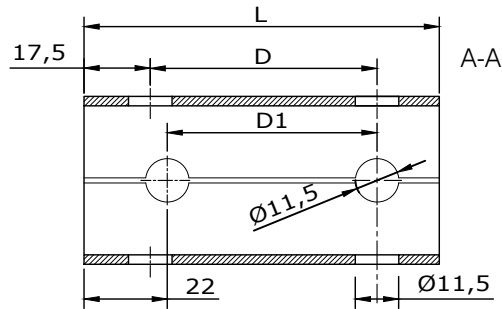
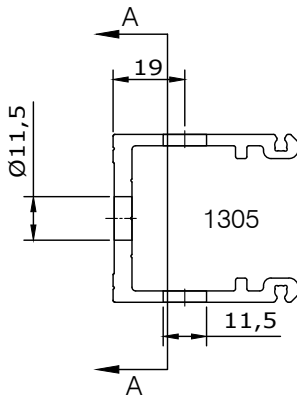
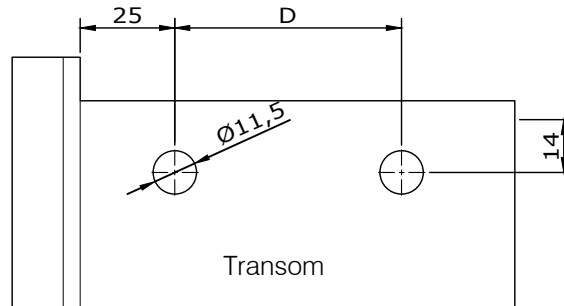
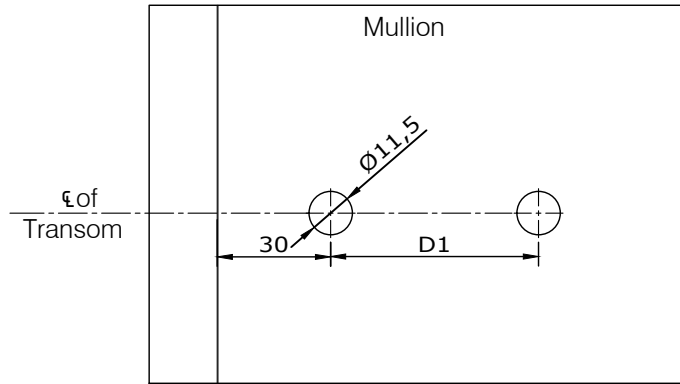

Note:
Cut cleats are for project only and are not held in stock. Cut cleats will be subject to a longer lead time.

Cleat Reference	Transom	L (mm)	D (mm)	D1 (mm)
2565	1166 - 125mm	104	75	70
2566	1152 - 135mm	114	75	70
2567	1145, 1154 & 150mm	129	100	95
2568	1147 - 175mm	154	125	120
2569	1156 - 180mm	159	130	125
2570	1157 - 195mm	174	145	140
2571	1148 - 200mm	179	145	140
2572	1158 - 210mm	189	161	156

Changes reserved
Sous reserve de modifications
Änderungen vorbehalten

Issue: 05
Date : 10-16

Fabrication

7

Comar 6EFT

Future Additions

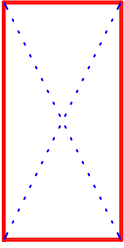

7.36

Fabricators Guide

FUTURE
ADDITION

Copyright and ownership of this drawing is vested in EFT,
Euro Facade Systems Ltd, whose prior written consent is required
for its use, reproduction or for publication to any third party.
All other rights reserved. Subject to modifications.

Facetted transom preparation
External Corner

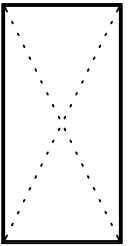

7.37

Fabricators Guide

Copyright and ownership of this drawing is vested in EFT, Euro Facade Systems Ltd, whose prior written consent is required for its use, reproduction or for publication to any third party. All other rights reserved.

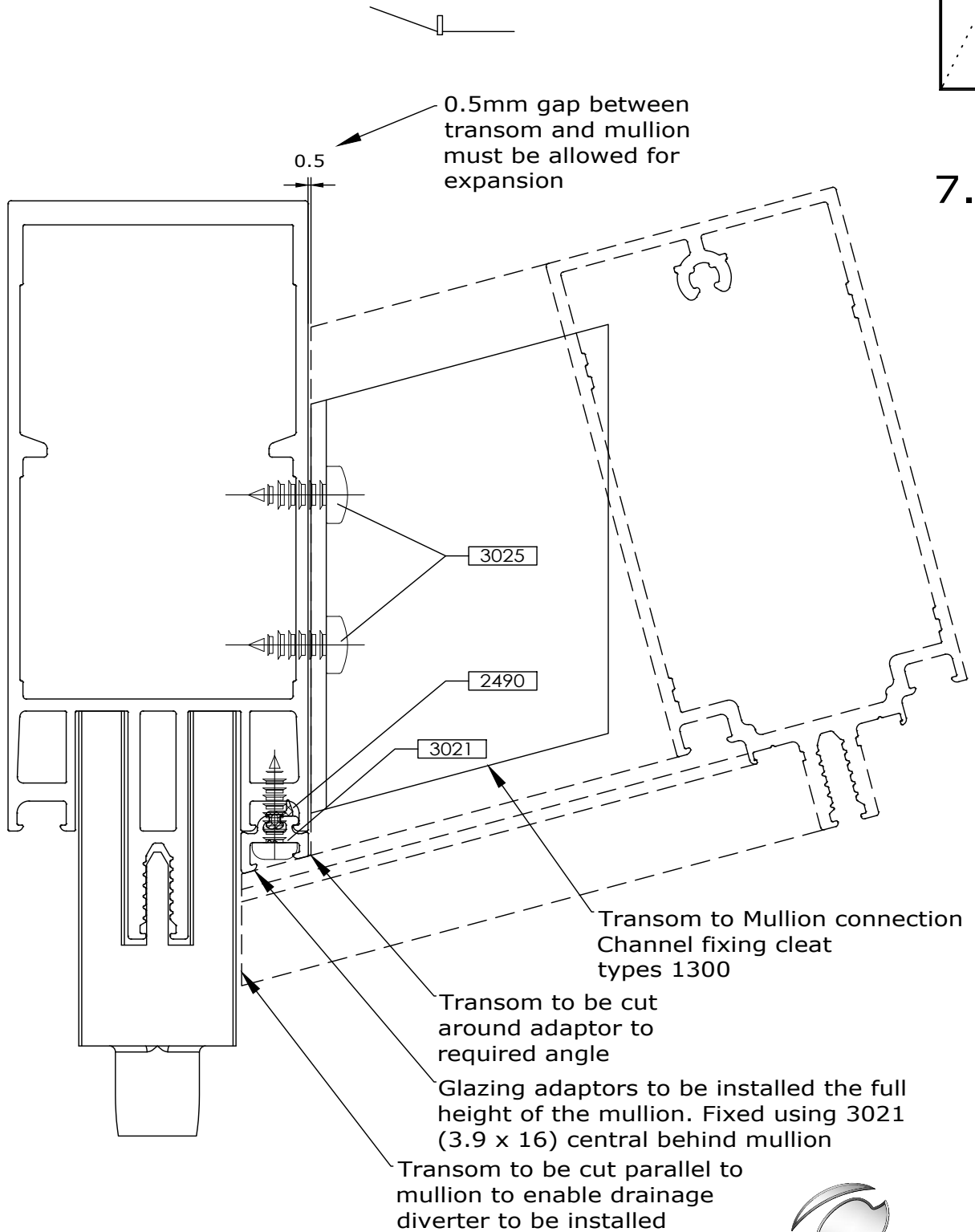

Changes reserved
Sous reserve de modifications
Änderungen vorbehalten

Issue: 05
Date: 10-16

Installation

7

Comar 6EFT

Facetted transom preparation Internal Corner

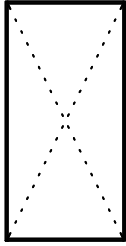

7.38

Fabricators Guide

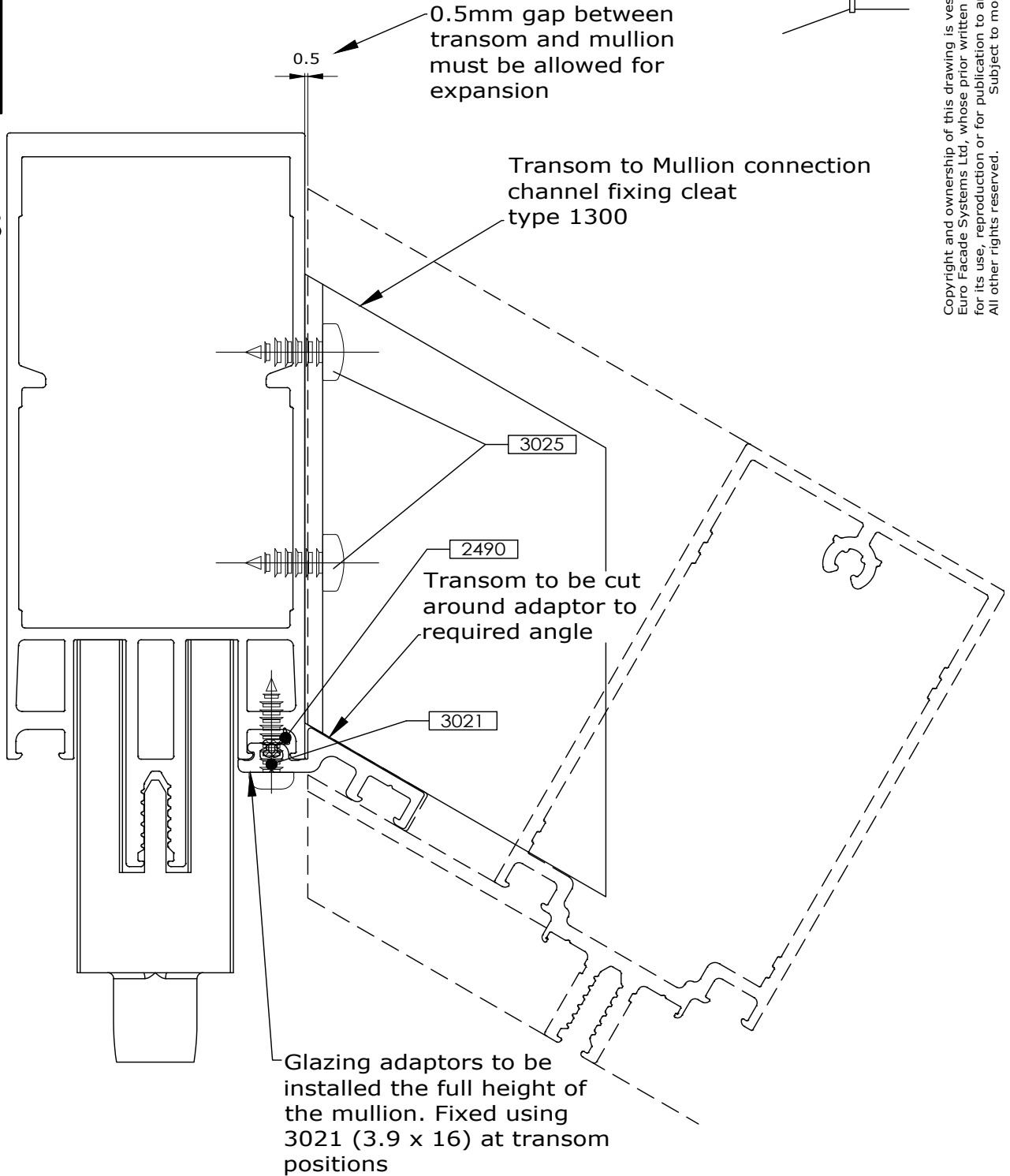

Copyright and ownership of this drawing is vested in EFT, Euro Facade Systems Ltd, whose prior written consent is required for its use, reproduction or for publication to any third party. All other rights reserved. Subject to modifications.



comar
ARCHITECTURAL ALUMINIUM SYSTEMS

Changes reserved
Sous reserve de modifications
Änderungen vorbehalten

Issue: 05
Date : 10-16

Fixing facatted transoms
External Corner

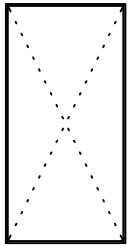

7.39

Copyright and ownership of this drawing is vested in EFT, Euro Facade Systems Ltd, whose prior written consent is required for its use, reproduction or for publication to any third party. All other rights reserved.

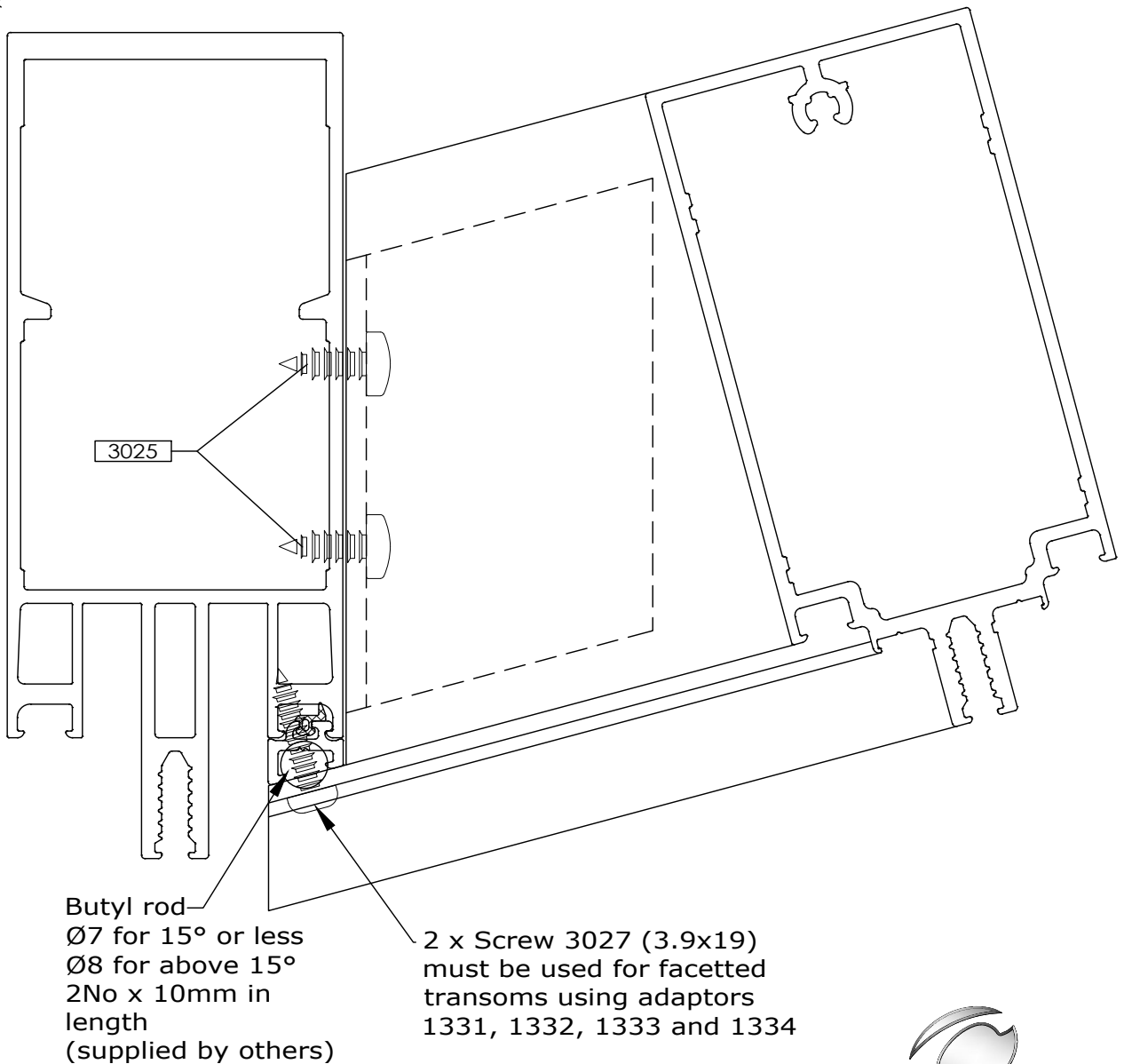
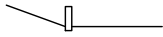

Butyl rod
Ø7 for 15° or less
Ø8 for above 15°
2No x 10mm in length
(supplied by others)

2 x Screw 3027 (3.9x19)
must be used for facatted
transoms using adaptors
1331, 1332, 1333 and 1334

Fabricators Guide

Changes reserved
Sous reserve de modifications
Änderungen vorbehalten

Issue: 05
Date: 10-16

Installation

7

Comar 6EFT

Fixing faceted transoms Internal Corner

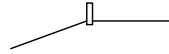
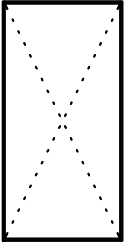

7.40

Fabricators Guide

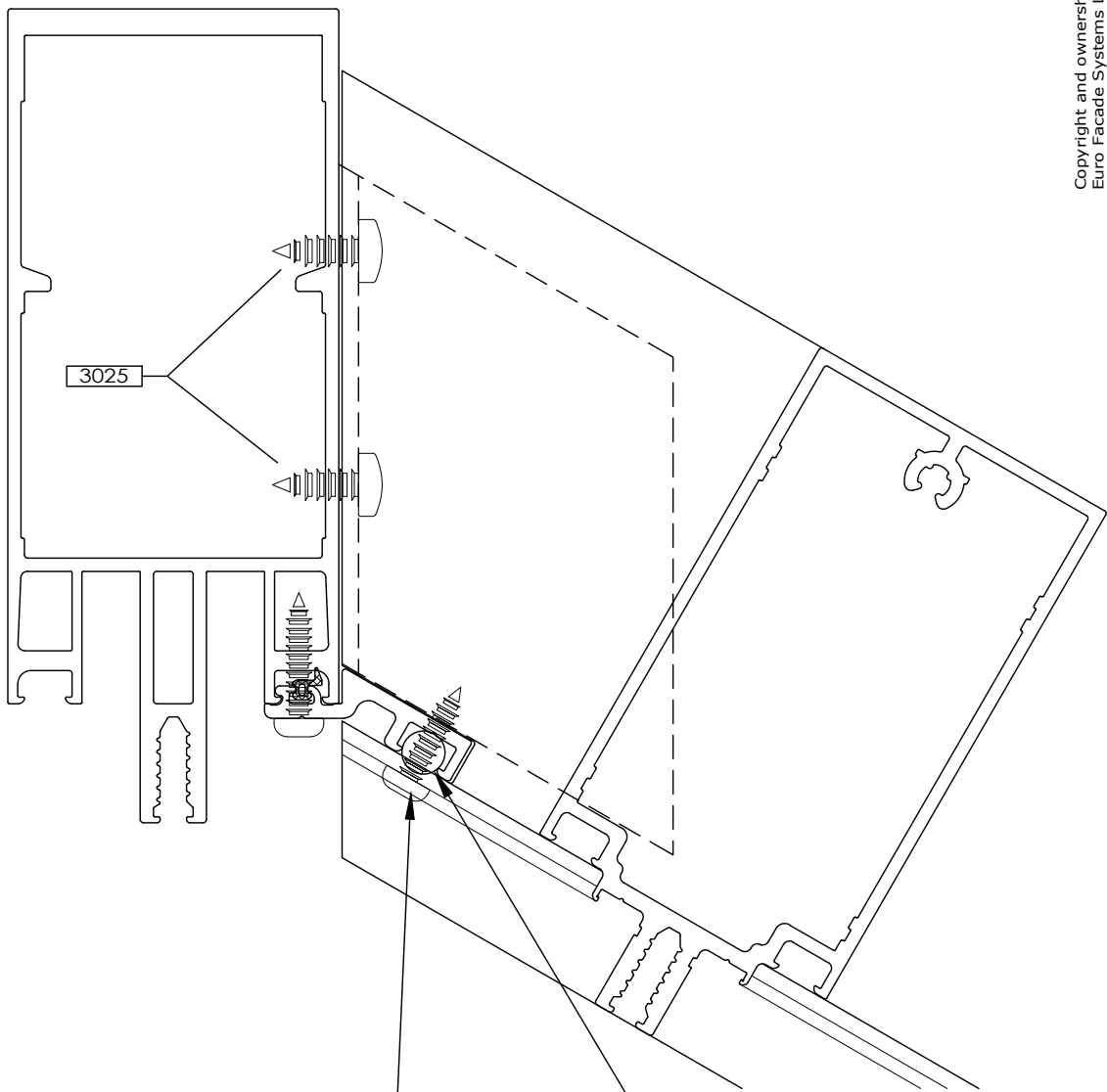

Transoms to be fixed to adaptor with screws 3021 (3.9x16)

For exact angle adaptors ie 7.5°, 15° etc, use transom pad 2028. For all other angles use butyl rod, Ø8mm, 27mm long, supplied by others.

Copyright and ownership of this drawing is vested in EFT, Euro Facade Systems Ltd, whose prior written consent is required for its use, reproduction or for publication to any third party. All other rights reserved. Subject to modifications.

Copyright and ownership of this drawing is vested in EFT, Euro Facade Systems Ltd, whose prior written consent is required for its use, reproduction or for publication to any third party. All other rights reserved.

7

Installation Comar 6EFT

Facatted transom Cleat Preparation External Corner

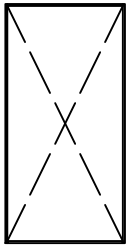

Any facatted transom must be held in place by cleats made from profile 1300 (or 1305 if specified)

Same cleat preparation can be used for outward (reflex) angles.

7.41

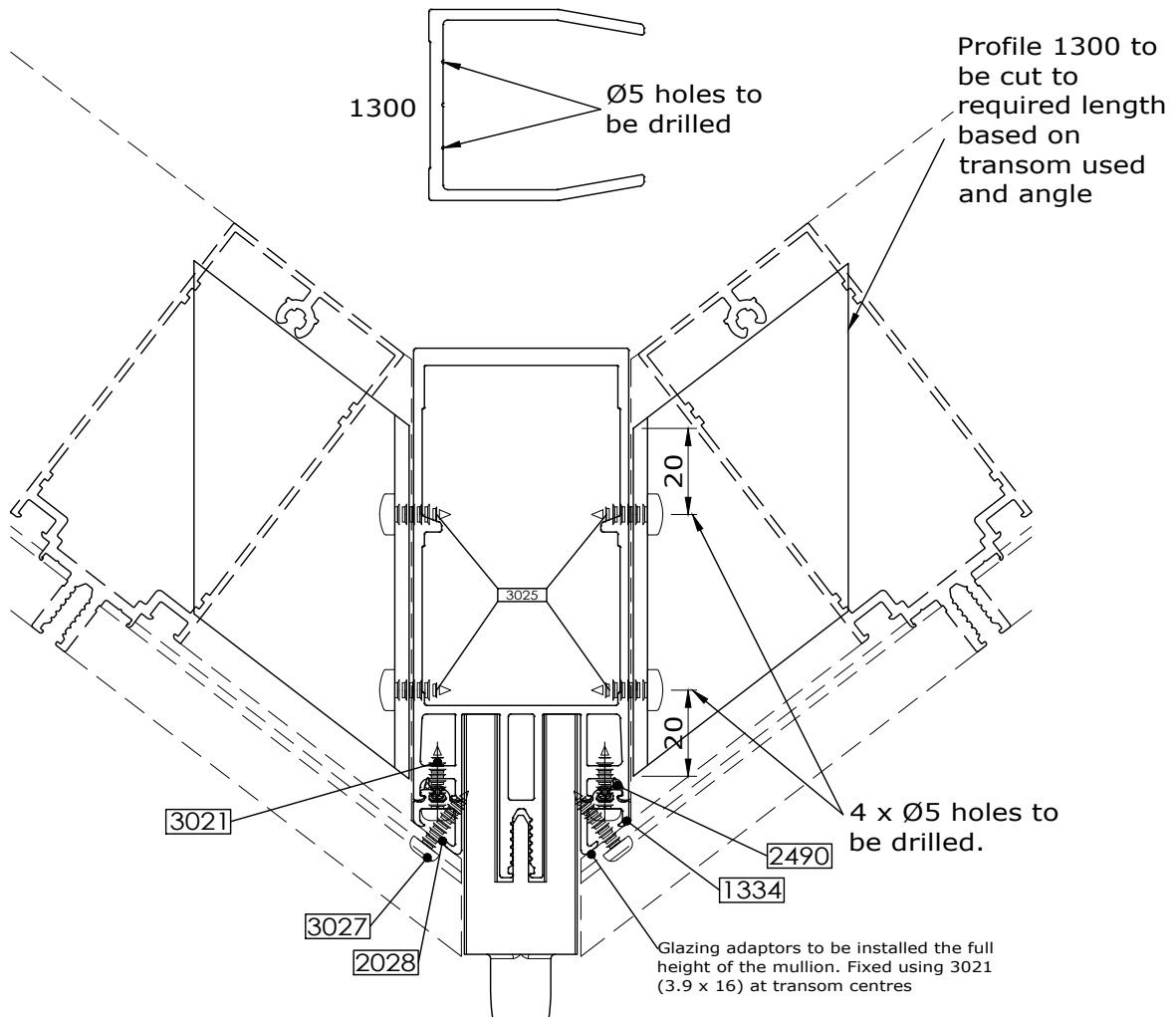

Fabricators Guide

Changes reserved
Sous reserve de modifications
Änderungen vorbehalten

Issue: 05
Date: 10-16

Installation

7

Comar 6EFT

Fixing adaptors 1264 & 1265

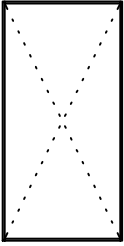

7.42

Fabricators Guide

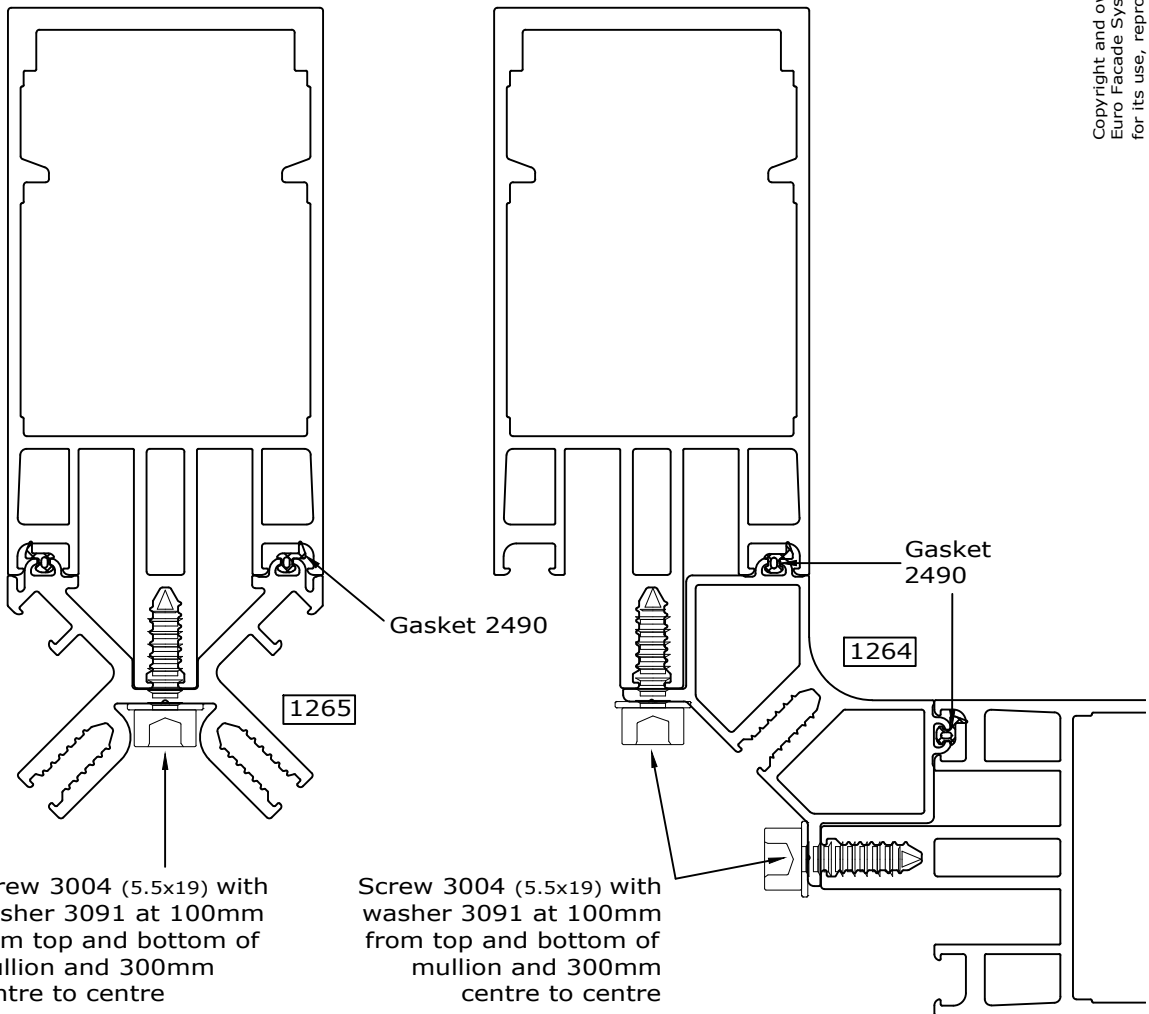

Copyright and ownership of this drawing is vested in EFT, Euro Facade Systems Ltd, whose prior written consent is required for its use, reproduction or for publication to any third party. All other rights reserved. Subject to modifications.



comar
ARCHITECTURAL ALUMINIUM SYSTEMS

Changes reserved
Sous reserve de modifications
Änderungen vorbehalten

Issue: 05
Date: 10-16

EPDM membrane Transom Sill, Head & Mullion preparation

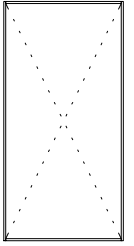

7.43

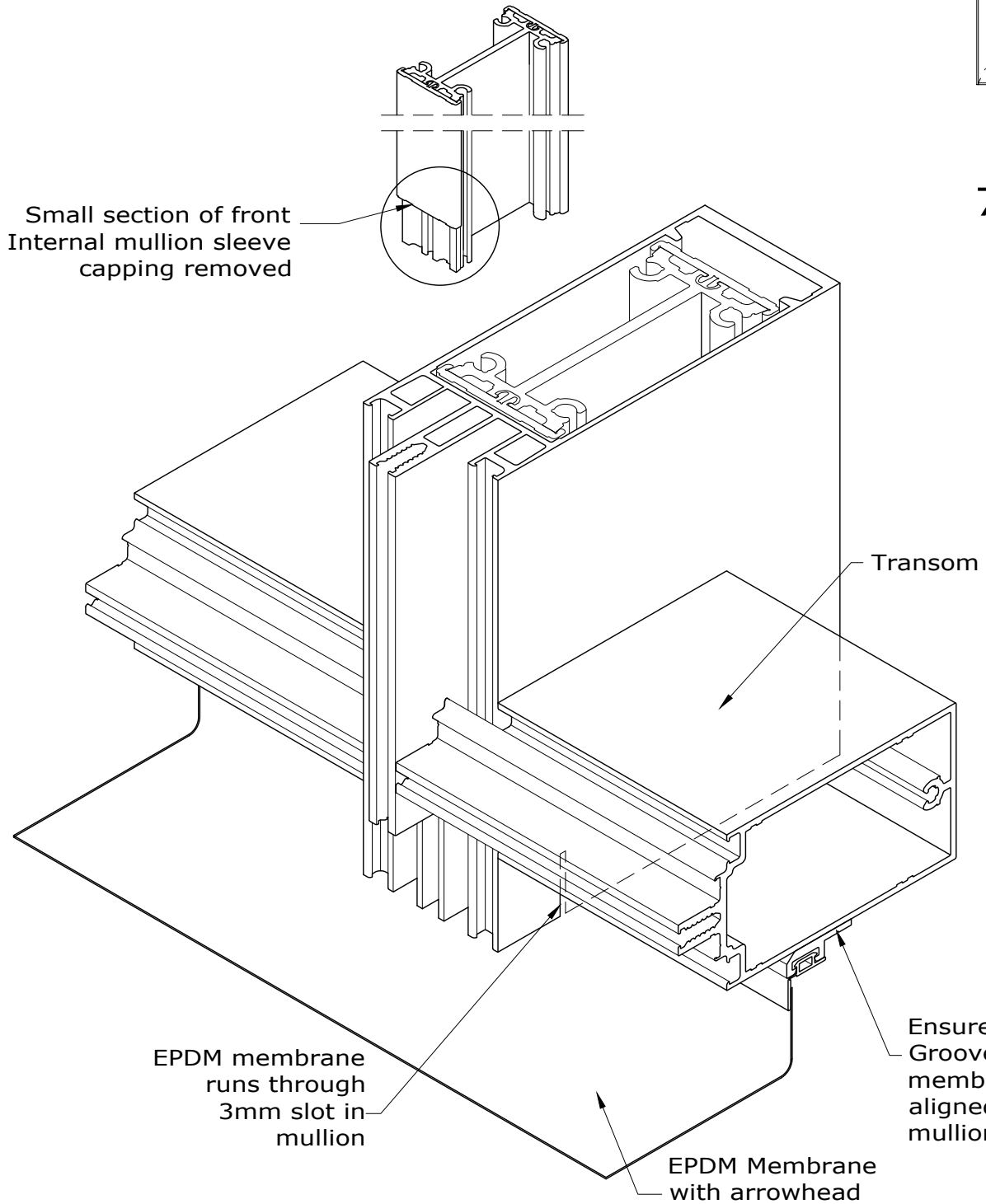

Installation

7

Comar 6EFT

EPDM membrane Curtain wall perimeter Preparation

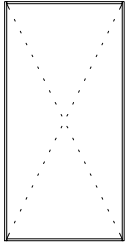

7.44

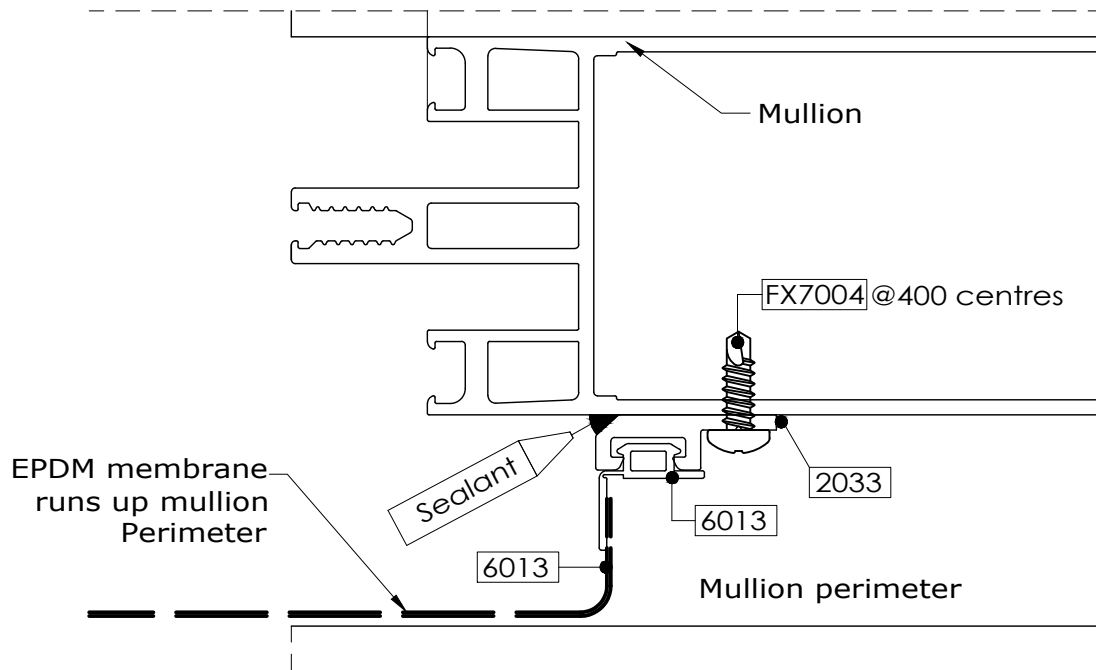

EPDM membrane runs up mullion Perimeter

sealant

Mullion

FX7004@400 centres

2033

Mullion perimeter

6013

Transom

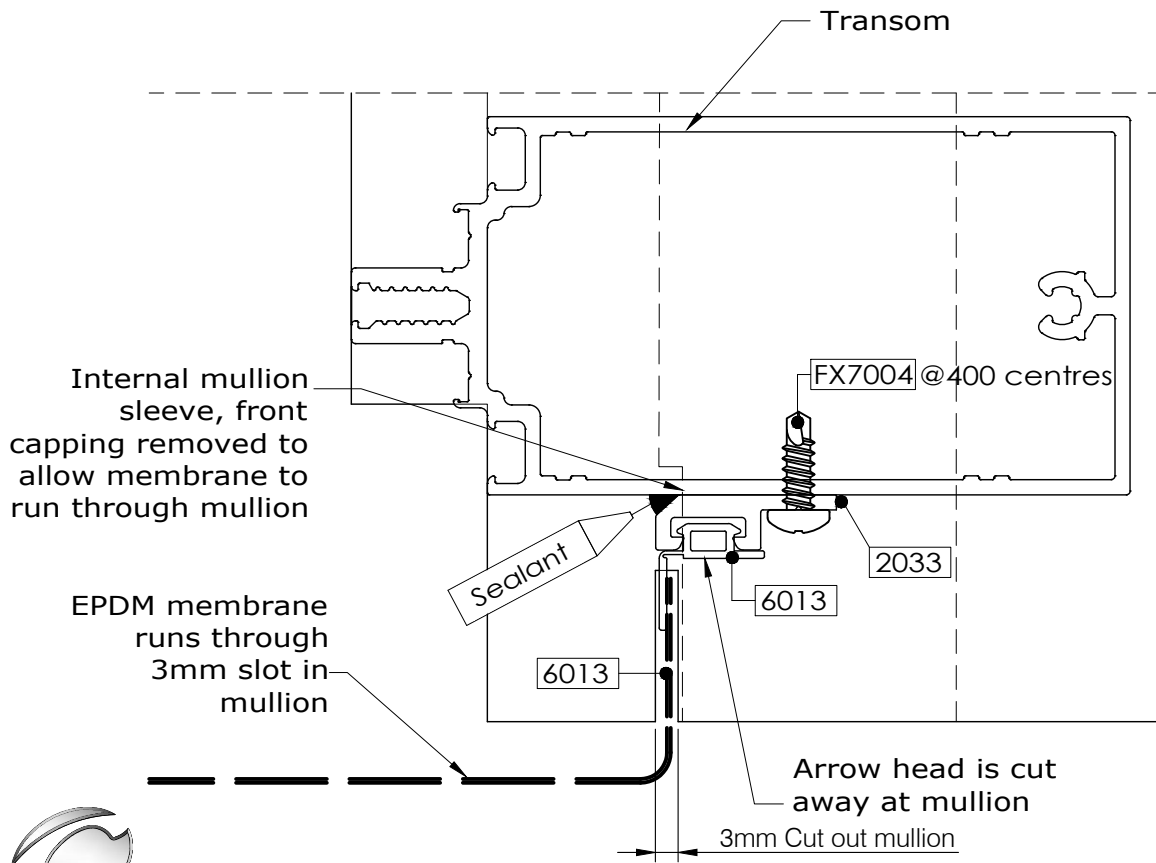

Internal mullion sleeve, front capping removed to allow membrane to run through mullion

EPDM membrane runs through 3mm slot in mullion

sealant

FX7004@400 centres

2033

Arrow head is cut away at mullion

3mm Cut out mullion

6013



Copyright and ownership of this drawing is vested in EFT, Euro Facade Systems Ltd, whose prior written consent is required for its use, reproduction or for publication to any third party. All other rights reserved. Subject to modifications.

7

Installation
Comar 6EFT

EPDM membrane
Mullion preparation
Slot cutting details

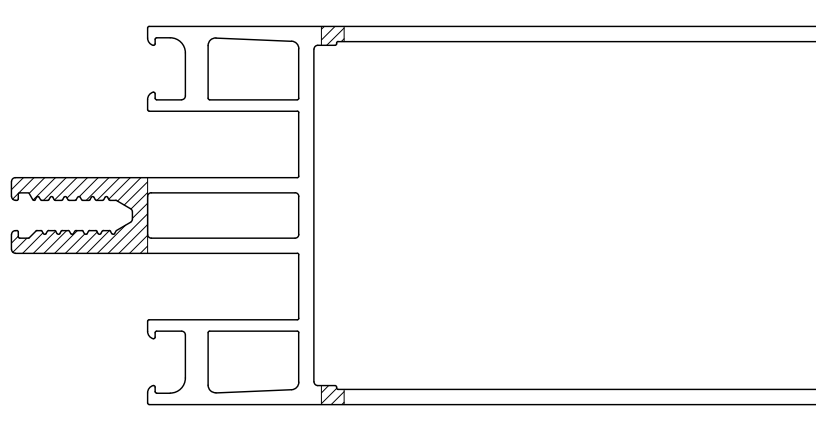
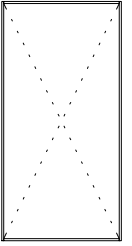

7.45

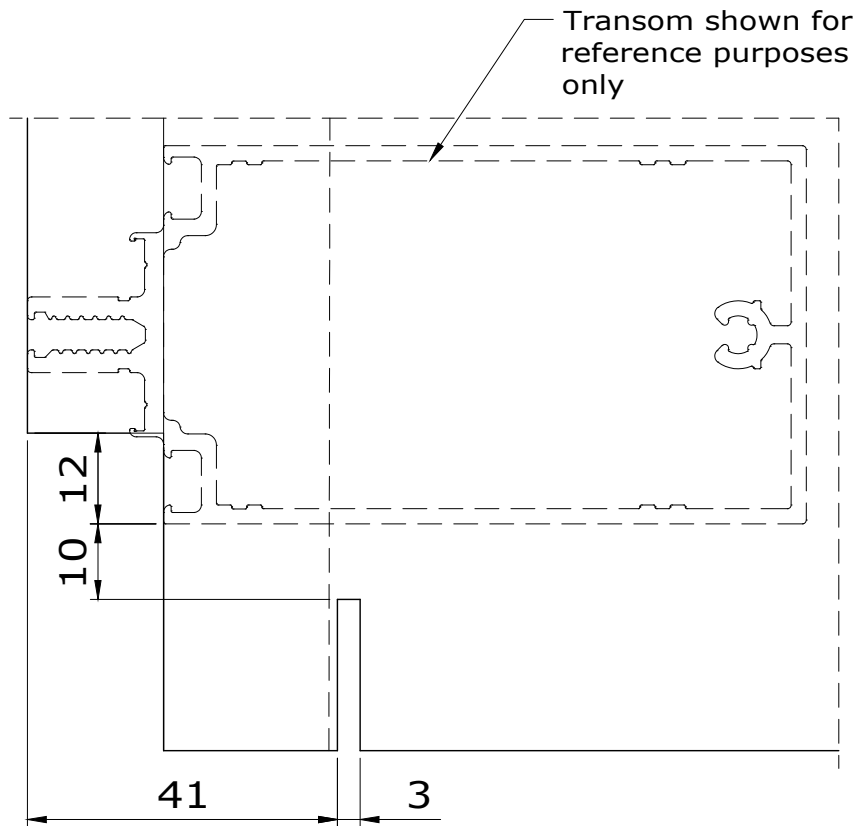

Fabricators Guide

Changes reserved
Sous reserve de modifications
Änderungen vorbehalten

Issue: 05
Date: 10-16

Installation

7

Comar 6EFT

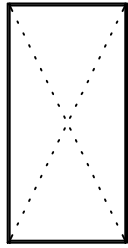

Apply Arbomeric MP20 sealant into glazing groove

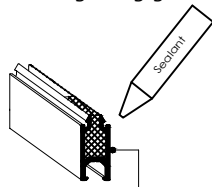

Install gasket 2490 wherever glazing adaptor is to be placed

7.46

Factory fitted glazing adaptor 1328 fixed with screw 3024 (4.2 mm x 25 mm) Max pitch of 1m. 2 off min.

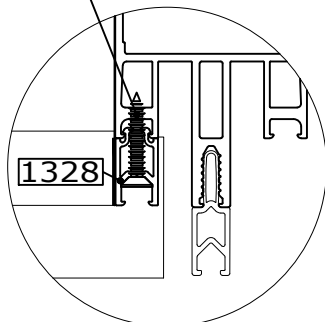

Factory fitted glazing adaptor 1329 fixed with screw 3026 (4.2 mm x 32 mm) 2 No min. Centres not more than 1m

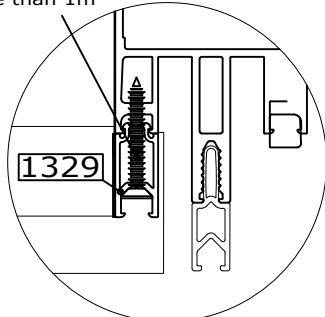

Factory fitted glazing adaptor 1330 fixed with screw 3028 (3.5 mm x 13 mm) Max pitch of 1m. 2 off min.

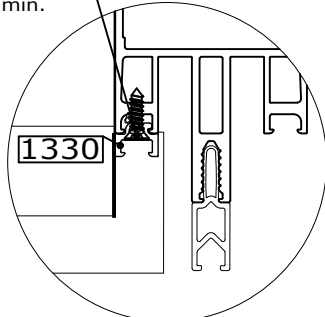

Glazing adaptors

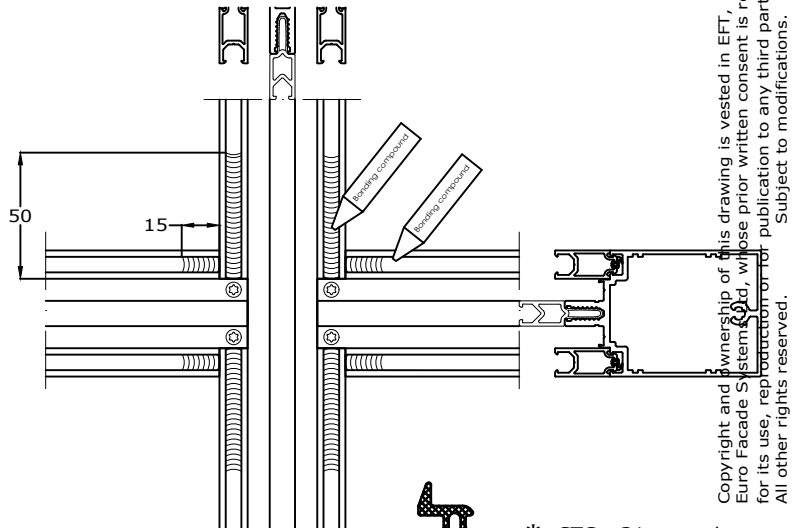

Inject vertical glazing adaptors at top with sealant and install adaptors



* CTC - 31 mm when the adaptor is bridging a mullion coupling

Seal horizontal glazing adaptor-faces with sealant

Install horizontal glazing adaptor

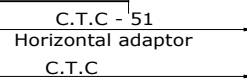
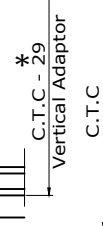
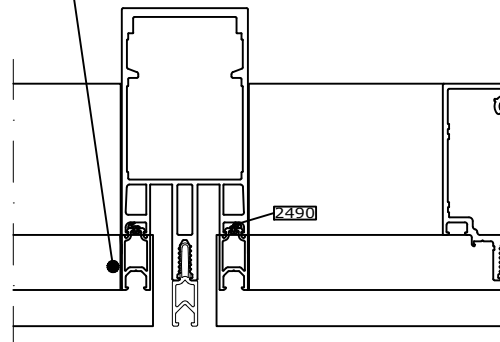

Copyright and ownership of this drawing is vested in EFT, Euro Facade System Ltd, whose prior written consent is required for its use, reproduction or publication to any third party. All other rights reserved.

Fabricators Guide



comar
ARCHITECTURAL ALUMINIUM SYSTEMS

Changes reserved
Sous reserve de modifications
Änderungen vorbehalten

Issue: 05
Date: 10-16

Internal gaskets & corners

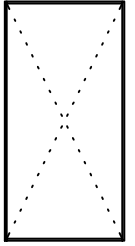

7.47

Apply bonding compound into glazing groove

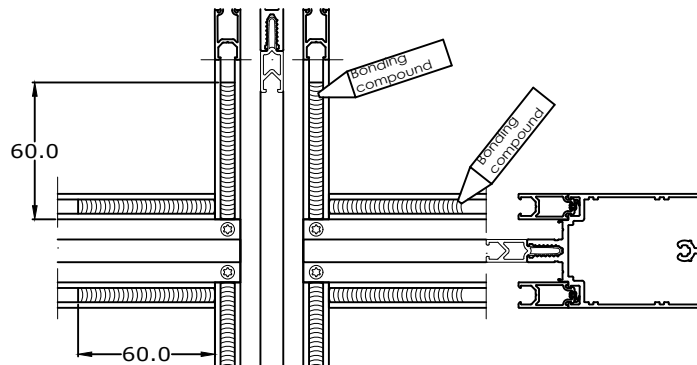

Install moulded gasket corners

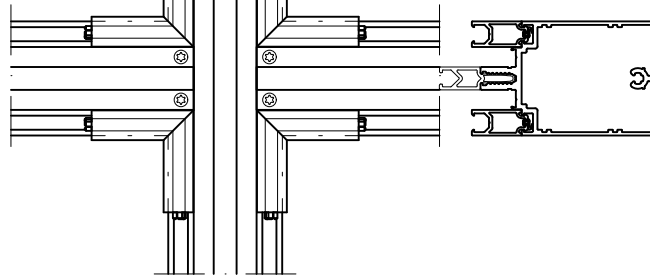

Cut EPDM glazing gasket to required length between corner mouldings $\pm 5\%$ to ensure compression of the gaskets

Bond corner to gasket joints using EPDM bonding compound or a MS Polymer based sealant

Slide gasket into position and clean off excess sealant

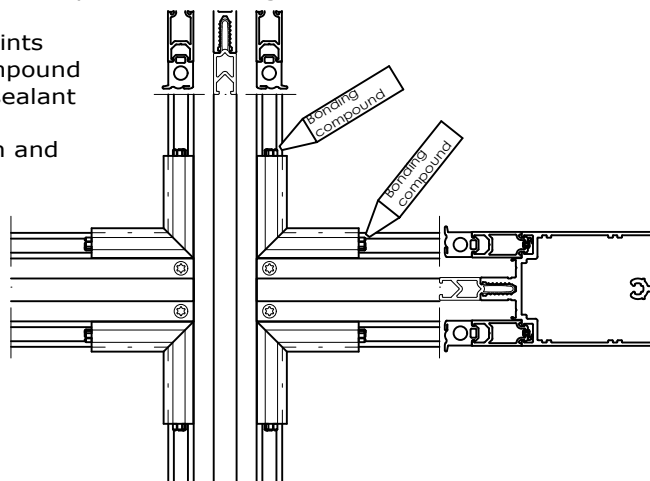

Installation

7

Comar 6EFT

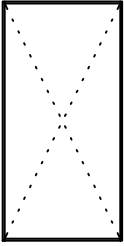

7.48

Location of glass setting blocks & temporary glazing aids

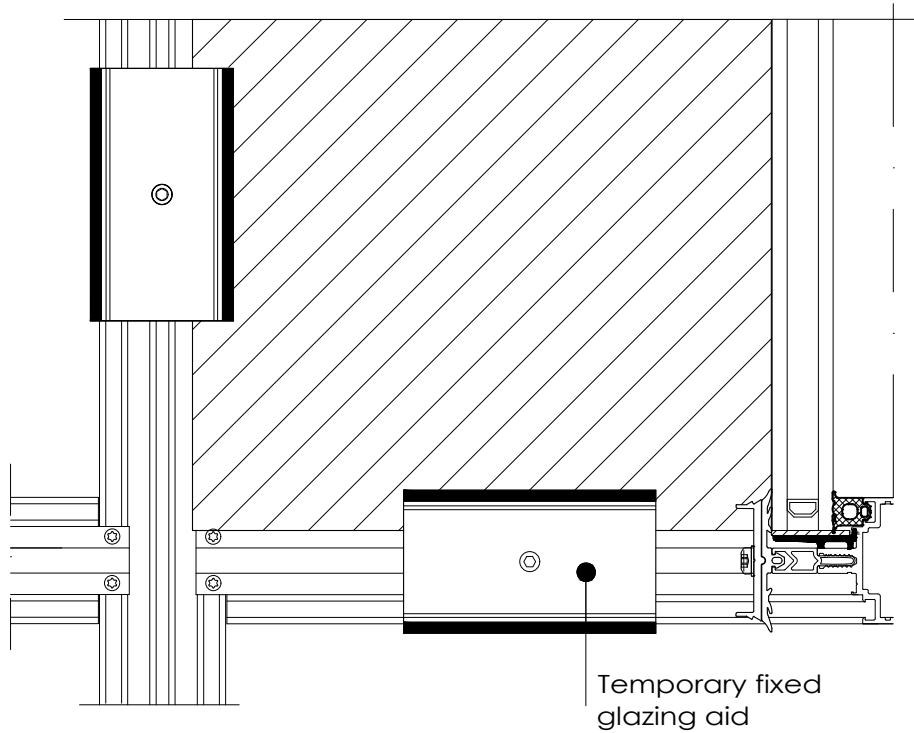
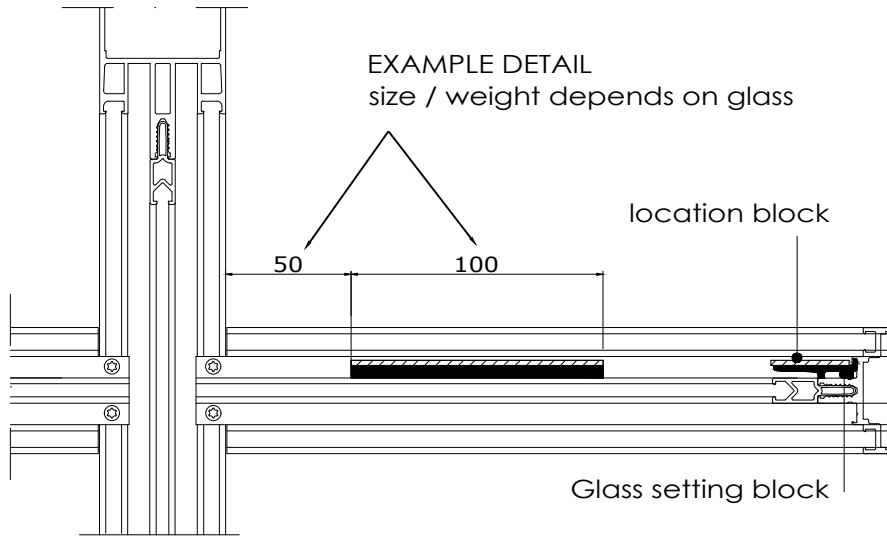

Copyright and ownership of this drawing is vested in EFT, Euro Facade Systems Ltd, whose prior written consent is required for its use, reproduction or for publication to any third party. All other rights reserved. Subject to modifications.

Fixing glazing insert and fixing clamp

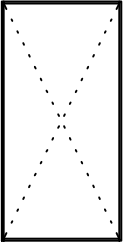

7.49

Copyright and ownership of this drawing is vested in EFT, Euro Facade Systems Ltd, whose prior written consent is required for its use, reproduction or for publication to any third party. All other rights reserved. Subject to modifications.

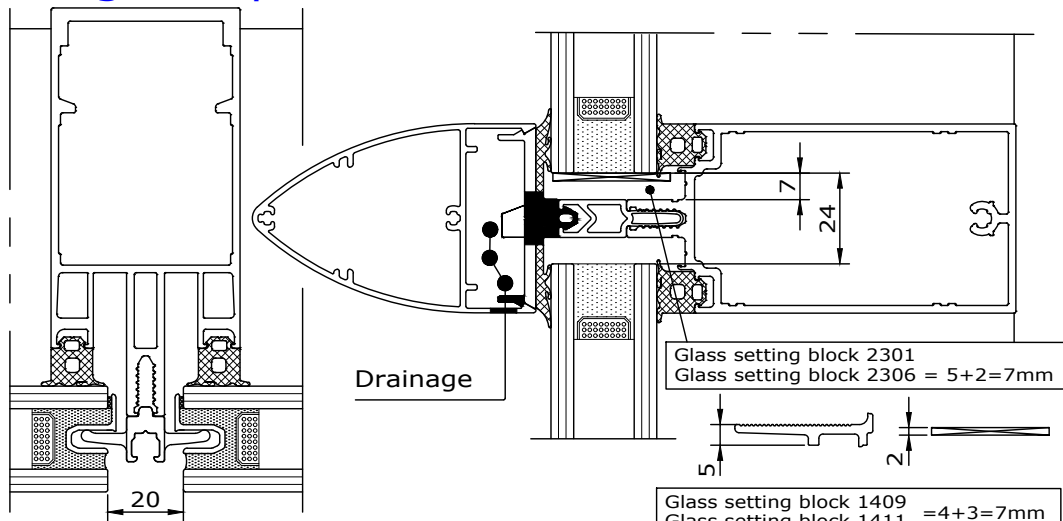

Glass setting block 2301
Glass setting block 2306 = 5+2=7mm

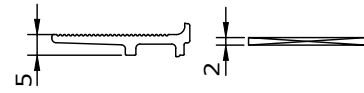

Glass setting block 1409
Glass setting block 1411 = 4+3=7mm

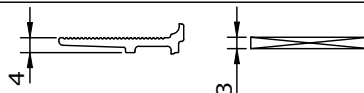

Glass setting block 1407
Glass setting block 1406
Glass setting block 1405
Glass setting block 1404 = 4+3=7mm
Glass setting block 1402
Glass setting block 1401
Glass setting block 1400

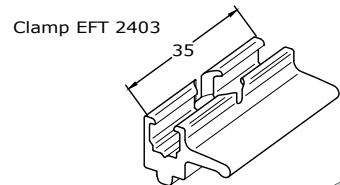
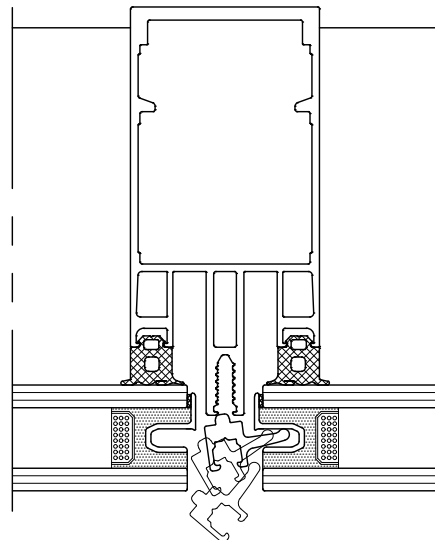
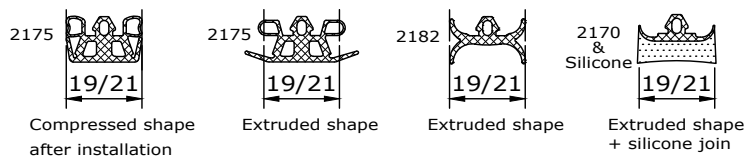
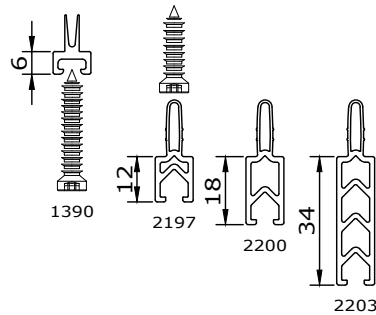
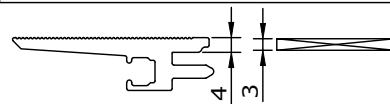

Changes reserved
Sous reserve de modifications
Änderungen vorbehalten

Issue: 05
Date: 10-16

Installation

7

Comar 6EFT

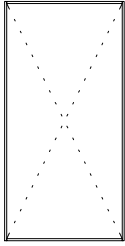

7.50

Location of glazing inserts,
fixing clamps and
glass setting block

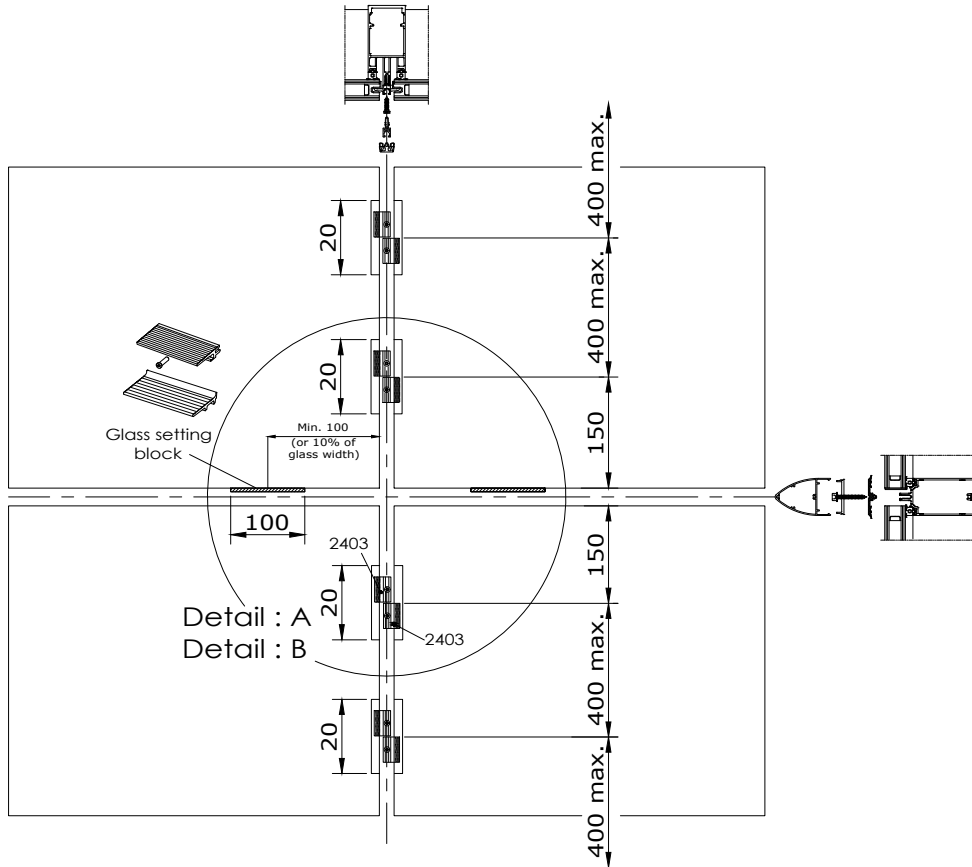

Location glazing insert and fixing clamps 2sided SGH (Two Sided Structural Glazed Horizontal cover cap)

1 Glazing inserts (EFT 2401, 2402, 2405, 2416, 2418, 2420)

Left & right edges of glass: Glazing inserts to be located 150mm edge of glass to center of glazing insert at either end. Inserts then spaced at 400mm max. center to center towards the center of the glass unit.

If the center of the glass unit is reached and there is more than a 400mm space between center of inserts, you may go up to a max. of 450mm C.T.C. between those inserts.

Left & right edges of glass: Dependant on wind load, building height and local situation, the glass manufacturer may approve that less inserts can be used. Transom C.T.C <700mm no clamps, C.T.C 700-1000mm 1 clamp, C.T.C 1000-1300mm 2 clamps, C.T.C 1300-1600mm 3 clamps etc.

2 Fixing clamp (EFT 2403)

To be fixed (with screw 5.5 x 23 - 3029 or 5.5x29- 3030)

3 Glass setting block (140x - series)

To be fixed (with screws 5.5 x 23 , 3029)

Location and spacing of glazing inserts & glass setting blocks to be approved by glass manufacturer.

Copyright and ownership of this drawing is vested in EFT,
Euro Facade Systems Ltd, whose prior written consent is required
for its use, reproduction or for publication to any third party.
Subject to modifications. All other rights reserved.

7

Installation

Comar 6EFT

Location of glazing inserts fixing damp and glass setting block

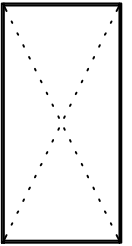

7.51

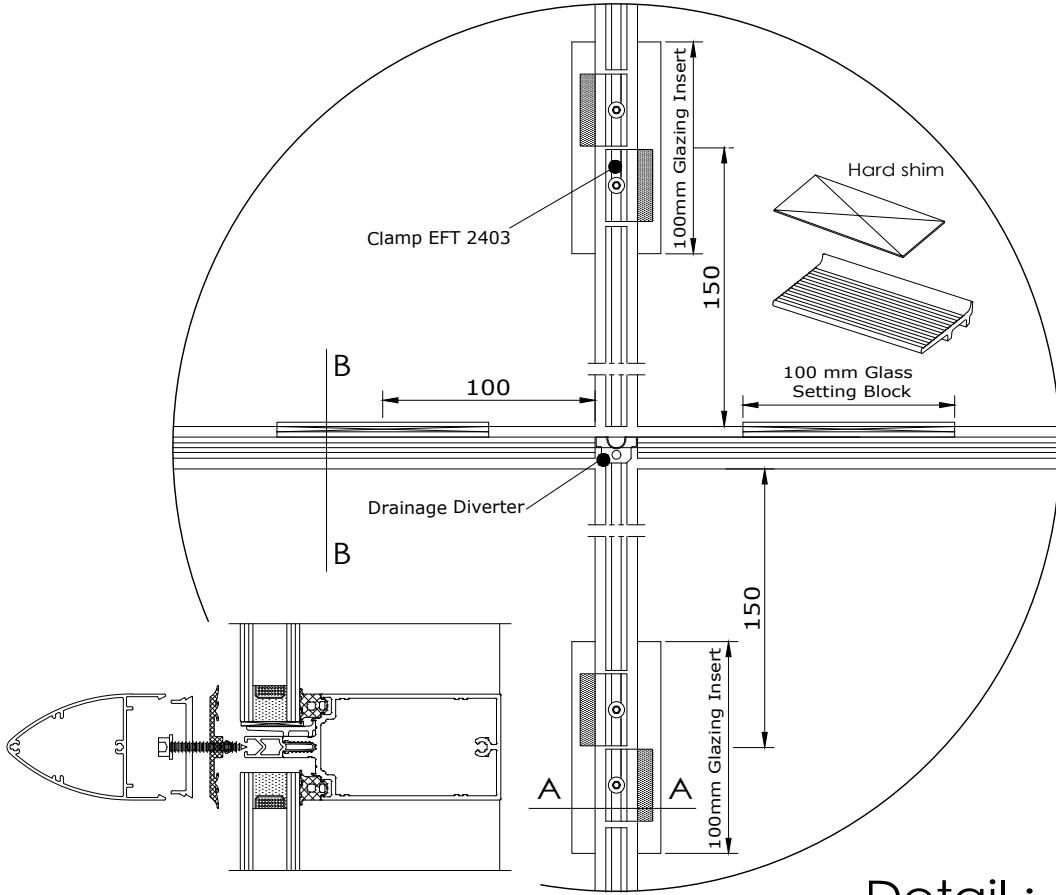

B - B

Detail : A

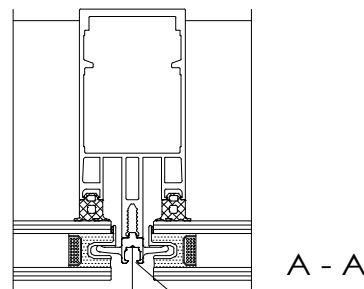
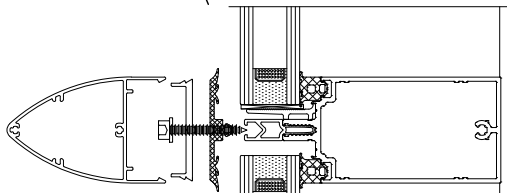

Screw 5.5 x 23 , 3029

Thermal break 12mm EFT 2197

(EPDM) Joint gasket 20 mm EFT 2175

(EPDM) Joint gasket 20 mm EFT 2182

Optional: Silicone Joint with (EPDM) gasket 20 mm EFT 2170 - use bond breaker tape at gasket / silicon joint

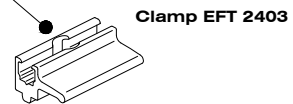

Clamp EFT 2403

Copyright and ownership of this drawing is vested in EFT, Euro Facade Systems Ltd, whose prior written consent is required for its use, reproduction or for publication to any third party. All other rights reserved.

Changes reserved
 Sous reserve de modifications
 Änderungen vorbehalten

Issue: 05
 Date: 10-16

Installation

7

Comar 6EFT

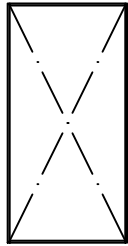

7.52

Location of glazing insert, fixing clamps and glass setting block

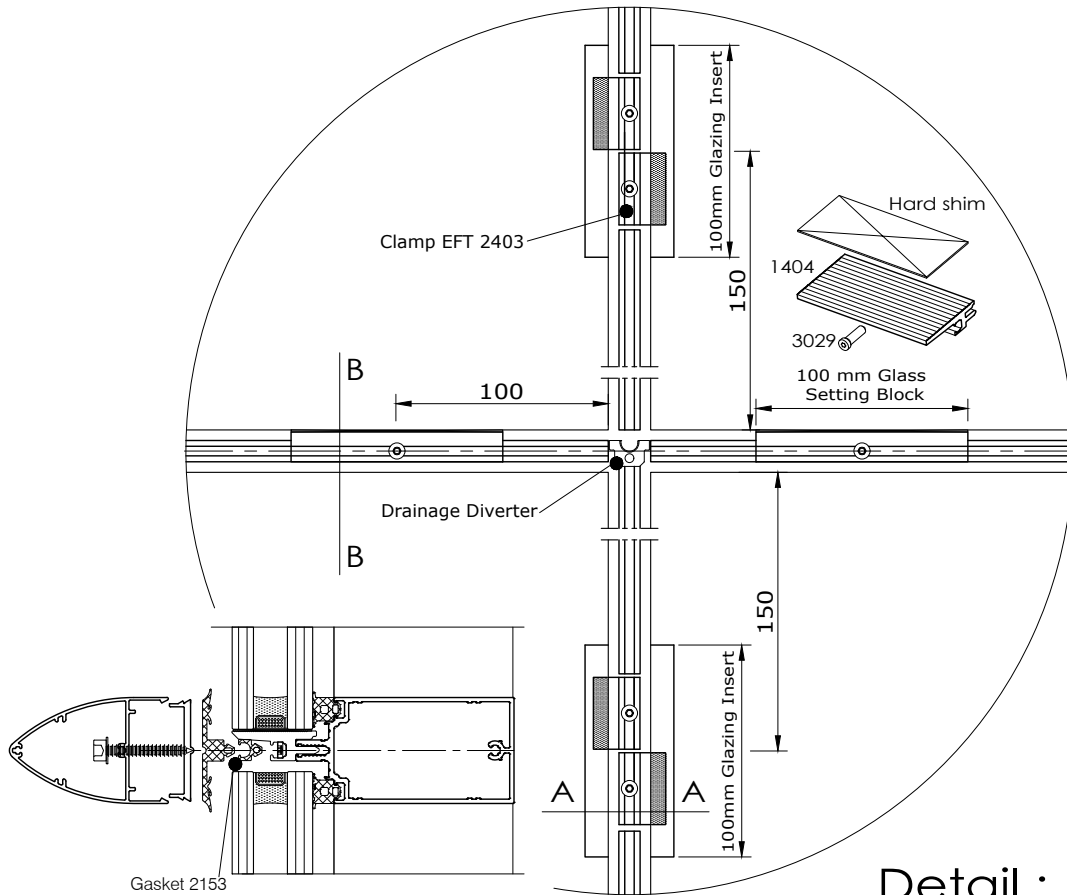

B - B

Detail : B

Gasket 2153
6mm thick, 100 mm length
2200 thermal break beyond

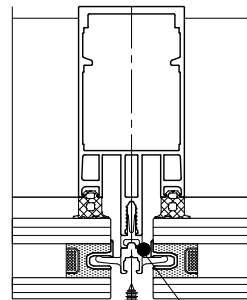

A - A

- Screw 5.5 x 29 , 3030
- Gasket 6mm , 2186
- Thermal break 18mm EFT 2200
- (EPDM) Joint gasket 20 mm EFT 2175
- (EPDM) Joint gasket 20 mm EFT 2182
- Optional: Silicone Joint with (EPDM) gasket 20 mm EFT 2170
- use bond breaker tape at gasket / silicon joint

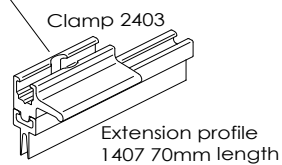

Clamp 2403

Extension profile
1407 70mm length

Copyright and ownership of this drawing is vested in EFT, Euro Facade Systems Ltd, whose prior written consent is required for its use, reproduction or for publication to any third party. All other rights reserved. Subject to modifications.

Fabricators Guide



comar
ARCHITECTURAL ALUMINIUM SYSTEMS

Changes reserved
Sous reserve de modifications
Änderungen vorbehalten

Issue: 05
Date: 10-16

Copyright and ownership of this drawing is vested in EFT, Euro Facade Systems Ltd, whose prior written consent is required for its use, reproduction or for publication to any third party. All other rights reserved.

7 Installation

Spacing of inserts and clamps

Comar 6EFT

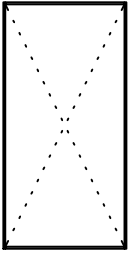

7.53

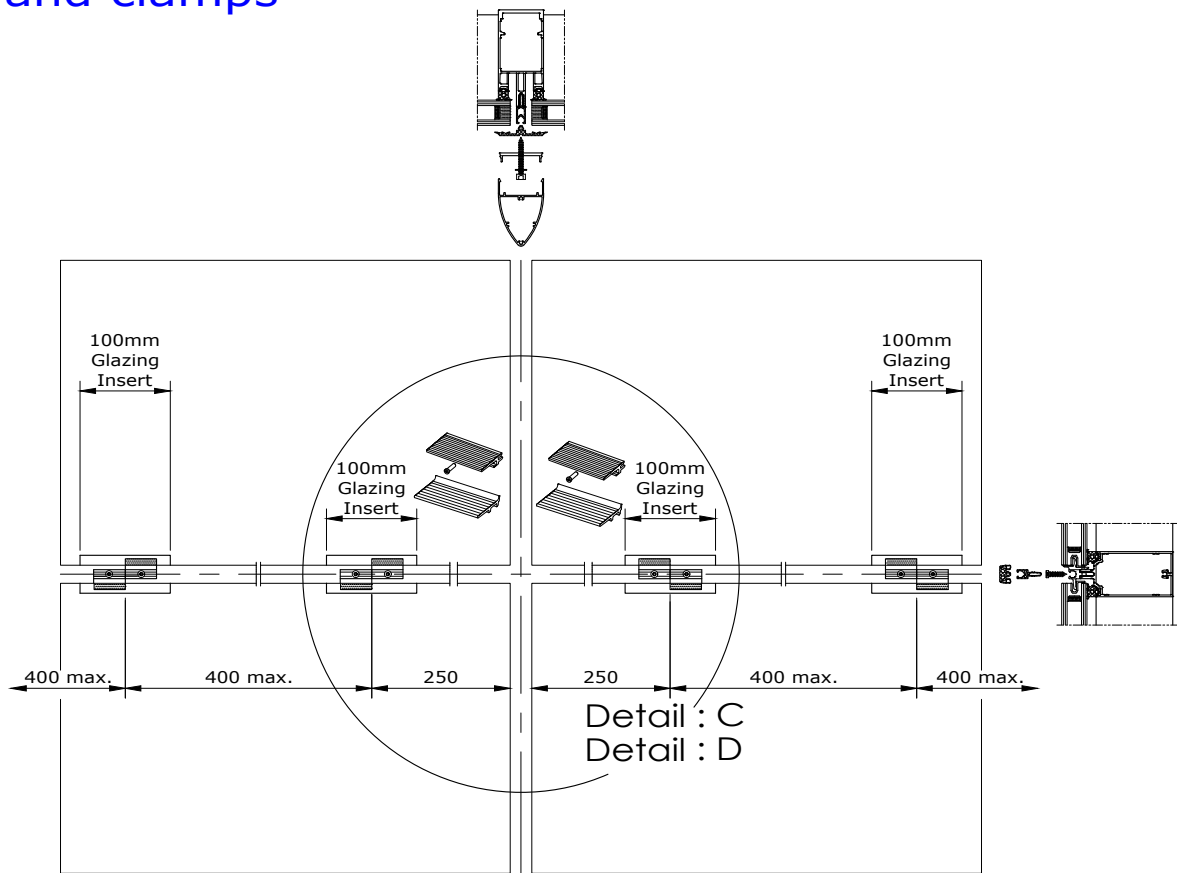

Location of glazing inserts and fixing clamps 2sided SGV (Two Sided Structural Glazed, vertical cover cap)

1 Glazing inserts (EFT 2401, 2402, 2405, 2416, 2418, 2420)

Top and bottom edge of glass: Glazing inserts to be located 250mm edge of glass to center of glazing insert at either end. Inserts then spaced at 400mm max. center to center towards the center of the glass unit.

If the center of the glass unit is reached and there is more than a 400mm space between center of inserts, you may go up to a max. of 450mm C.T.C. between those inserts.

Transom C.T.C < 700mm no clamps, C.T.C 700-1000mm 1 clamp, C.T.C 1000-1300mm 2 clamps, C.T.C 1300-1600mm 3 clamps etc.

Dependant on wind load, building height and local situation, the glass manufacturer may approve that less or more inserts can be used.

2 Fixing clamp (EFT 2403)

Clamps to be fixed (with screw 5.5x 23 - 3029 or 5.5x29- 3030)

3 Glass setting block (140x - series)

To be fixed (with screws 5.5 x 23 , 3029)

Location and spacing of glazing inserts & glass setting blocks to be approved by glass manufacturer.

Changes reserved
Sous reserve de modifications
Änderungen vorbehalten

Issue: 05
Date: 10-16

Installation

7

Comar 6EFT

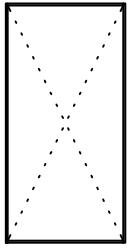

Location of glazing inserts, fixing clamps and glass setting block

7.54

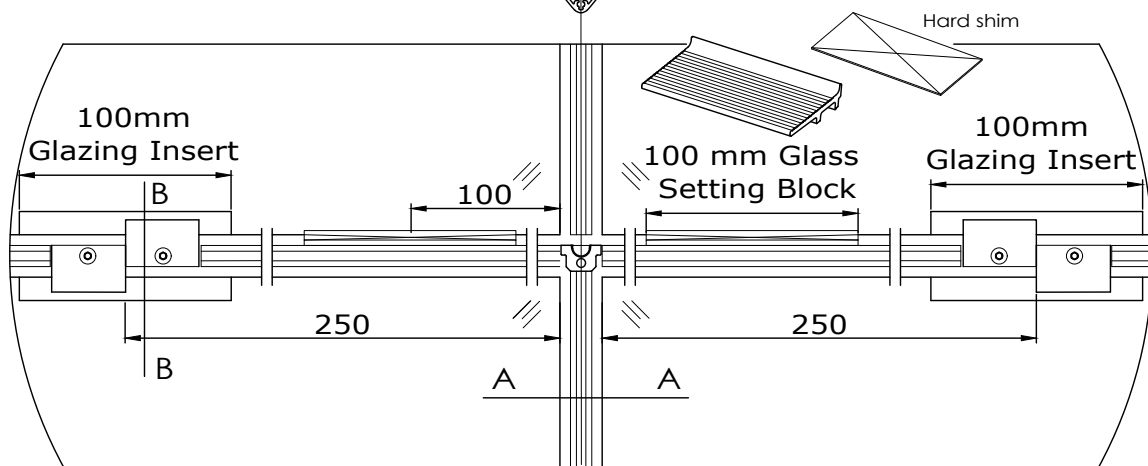
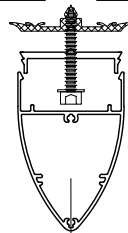
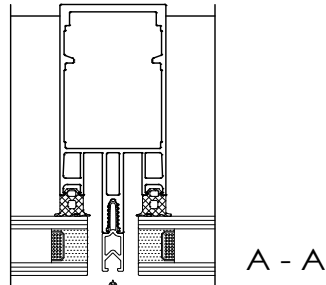

Copyright and ownership of this drawing is vested in EFT, Euro Facade Systems Ltd, whose prior written consent is required for its use, reproduction or for publication to any third party. All other rights reserved. Subject to modifications.

Fabricators Guide

Detail : C

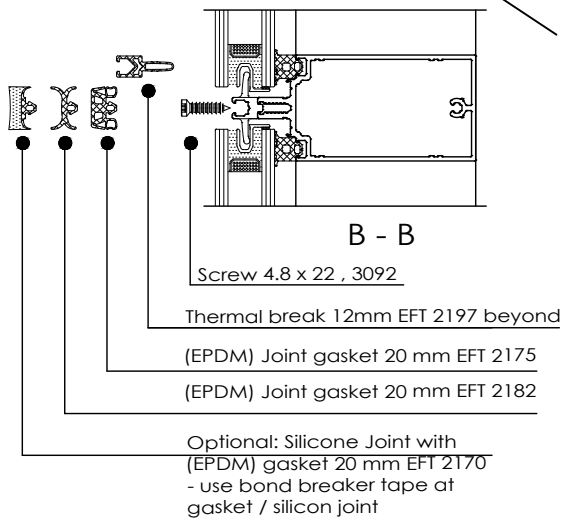

Copyright and ownership of this drawing is vested in EFT, Euro Facade Systems Ltd, whose prior written consent is required for its use, reproduction or for publication to any third party. All other rights reserved. Subject to modifications.

7

Installation

Comar 6EFT

Location of glazing insert fixing damp and glass setting block

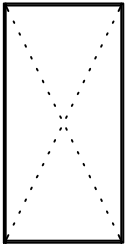

7.55

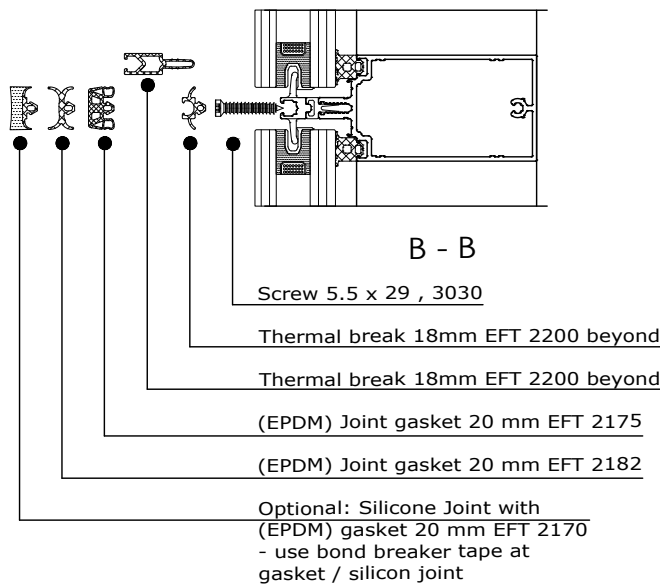
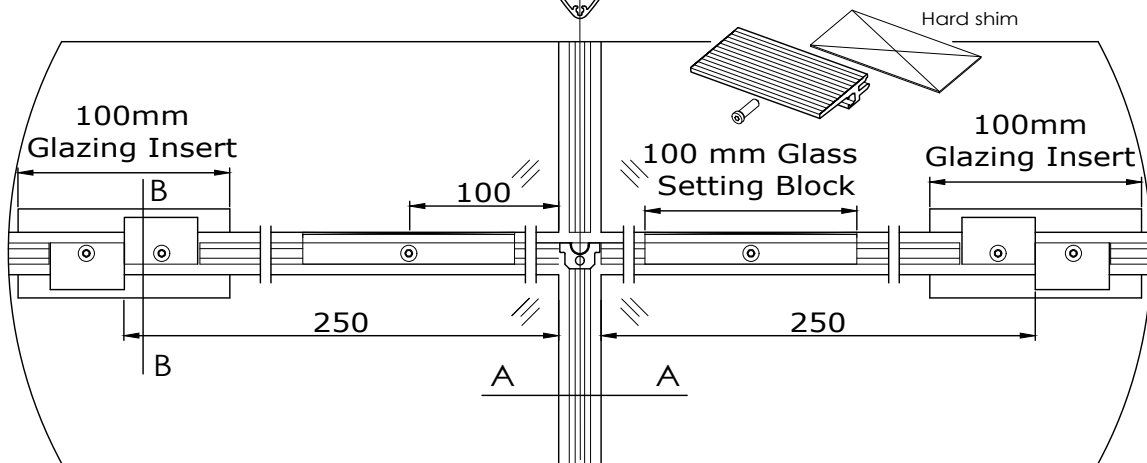
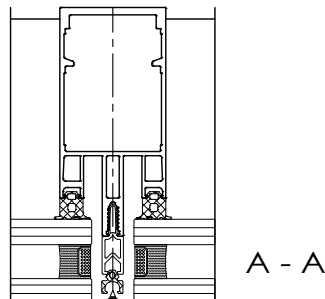

Detail : D

Fabricators Guide

Changes reserved
 Sous reserve de modifications
 Änderungen vorbehalten

Issue: 05
 Date: 10-16



Installation

7

Comar 6EFT

Spacing of insert, dampers and glass setting blocks

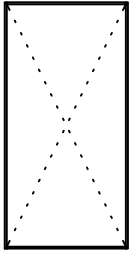

7.56

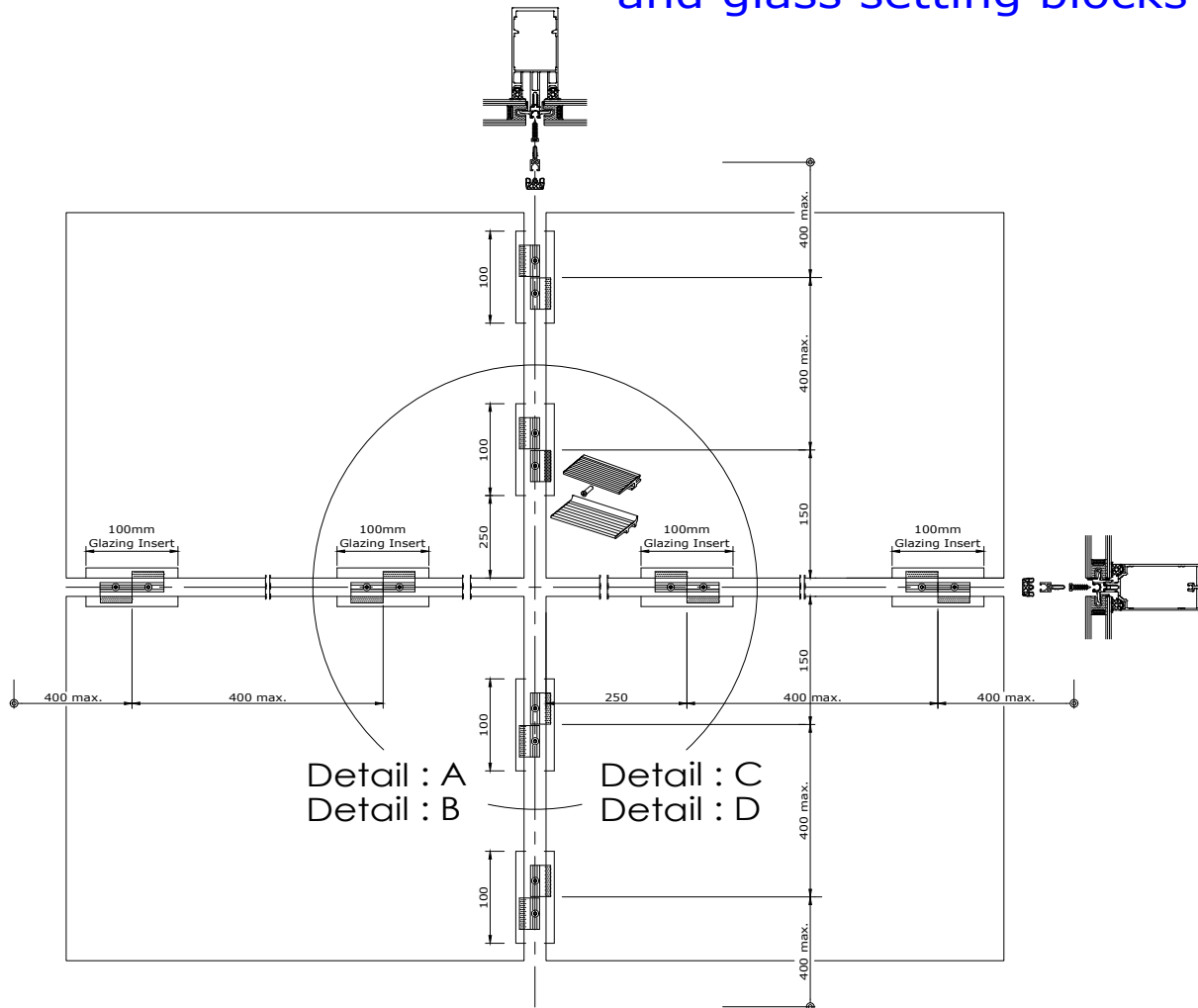

Copyright and ownership of this drawing is vested in EFT, Euro Facade Systems Ltd, whose prior written consent is required for its use, reproduction or for publication to any third party. All other rights reserved. Subject to modifications.

Fabricators Guide

Location glazing insert and fixing clamps - 4 sided Structural Glazing

1 Glazing inserts (EFT 2401, 2402, 2405, 2416, 2418, 2420)

Top and bottom edge of glass: Glazing inserts to be located 250mm edge of glass to center of glazing insert at either end. Inserts then spaced at 400mm max. center to center towards the center of the glass unit.

Left & right edges of glass: Glazing inserts to be located 150mm edge of glass to center of glazing insert at either end. Inserts then spaced at 400mm max. center to center towards the center of the glass unit.

If the center of the glass unit is reached and there is more than a 400mm space between center of inserts, you may go up to a max of 450mm C.T.C. between those inserts.

2 Fixing clamp (EFT 2403)

Clamps to be fixed (with screw 5.5 x 23 - 3029 or 5.5 x 29 - 3030)

3 Glass setting block (140 x - series)

To be fixed (with screws 5.5 x 23 , 3029)

Location and spacing of glazing inserts & glass setting blocks to be approved by glass manufacturer.



Thermal break installation

Comar 6EFT

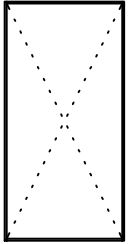

For correct isolator/thermal break, refer to glazing charts in section 3.

2 or 4 sided structural glazing

The thermal break must be cut to length between glass setting blocks and clamps.

7.57

Isolator/thermal break to be sealed as shown below in all configurations.

Where a drainage diverter is installed

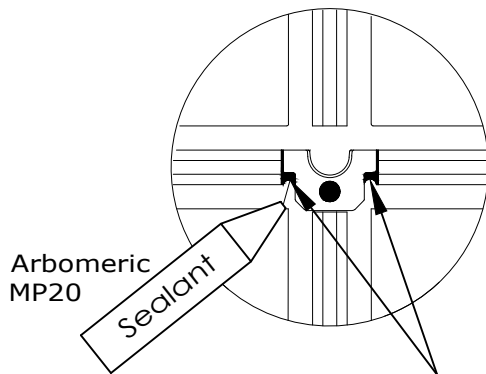

Apply sealant at both edges of transom-thermal break

Where no drainage diverter is installed

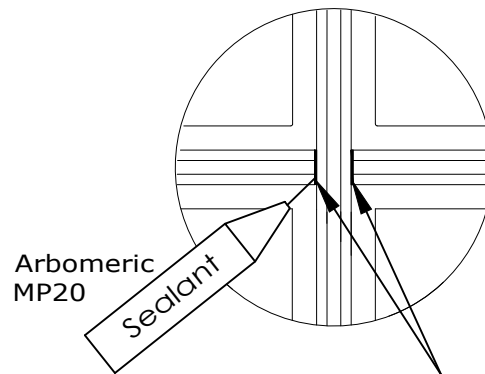

Apply sealant at both edges of transom-thermal break

Installation

7

Comar 6EFT

Drainage diverter Installation

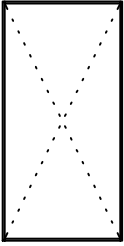

Drainage diverters are to be installed:

- On each mullion at the transom joint nearest the ground.
- Upside down at the highest mullion-transom joint.
- Each mullion for the cruciform above each mullion joint.
- The mullion-transom joint above any doors.

Notes:

7.58

- A drainage diverter at every cruciform for zone drainage is optional.
- For 4 sided structural jobs, spout of drainage diverter to be cut back to 3mm long. Refer to page 7.41.
- For correct drainage diverter, refer to glazing charts in section 3.

Locate drainage diverter ensuring it is pushed back flush with the mullion

Inject sealant into hole in drainage diverter and ensure sealant covers all sides

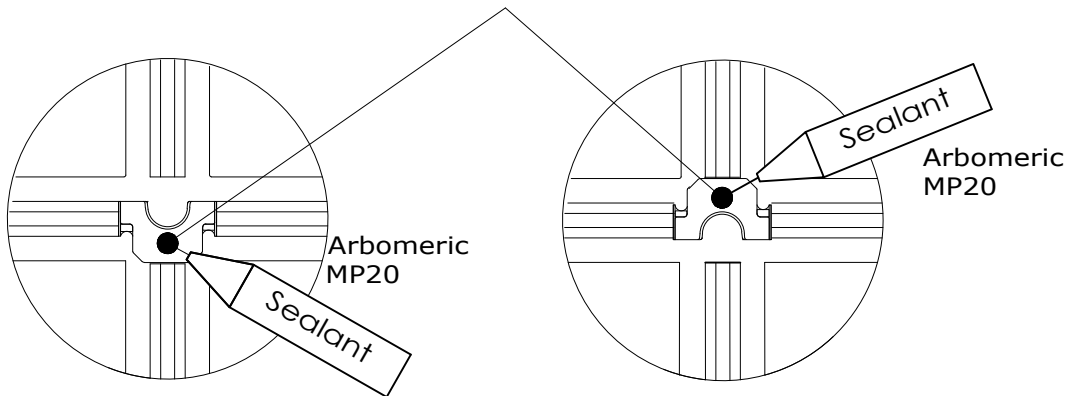

- Lowest mullion-transom joint
- Cruciform above each mullion joint
- At mullion-transom connection above doors
- Installed upside down at highest mullion-transom > 3m in height (for pressure equalisation)

Connection Drainage diverters XX2023 (50mm) & Extension drainage diverter (35mm) XX2032

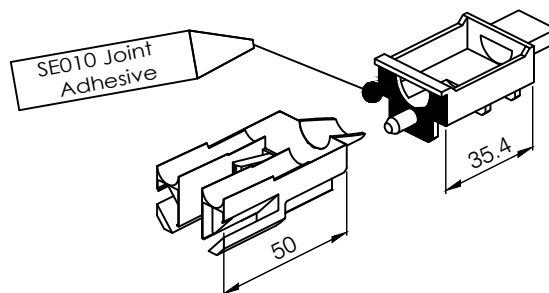

Copyright and ownership of this drawing is vested in EFT, Euro Facade Systems Ltd, whose prior written consent is required for its use, reproduction or for publication to any third party. All other rights reserved. Subject to modifications.

7

Installation

Comar 6EFT

4sided SG drainage & ventilation detail

TOP
DETAIL

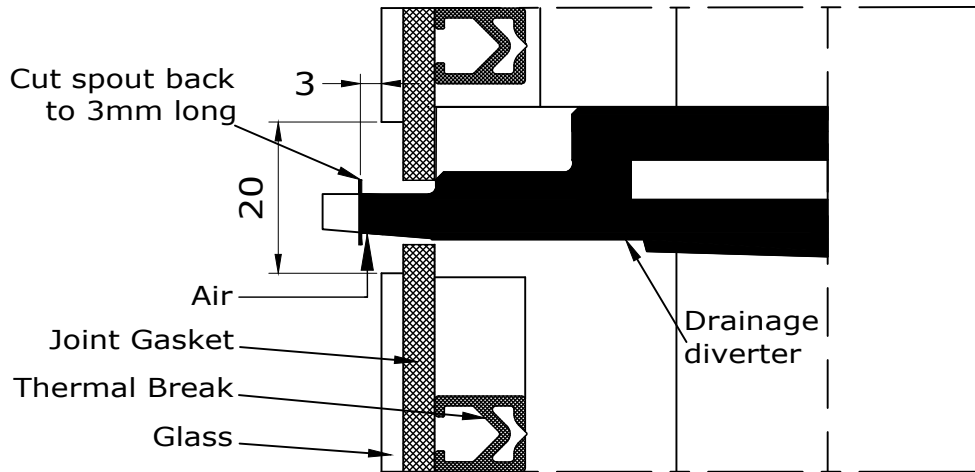

7.59

INTERMEDIATE
& BOTTOM
DETAIL

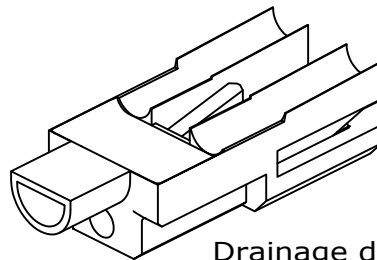
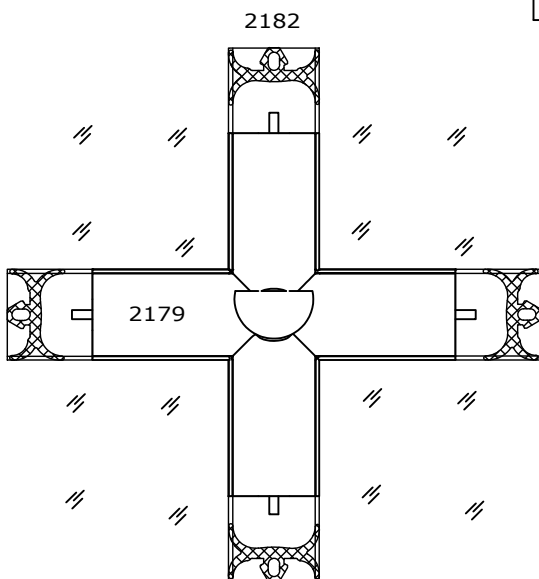
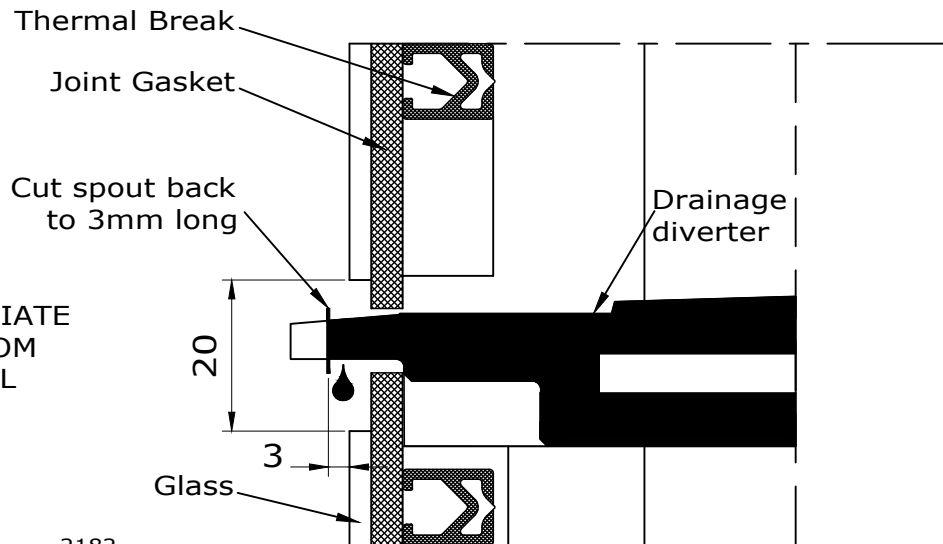

- Drainage diverter:
- 2021 50mm
 - 2019 54mm
 - 2020 56mm
 - 2026 64mm
 - 2027 72mm

Fabricators Guide

Changes reserved
Sous reserve de modifications
Änderungen vorbehalten

Issue: 05
Date: 10-16

Instalation

7

Comar 6EFT

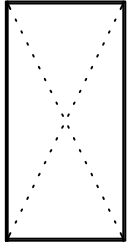

7.60

Drainage & Ventilation by Individual Window

Fabricators Guide

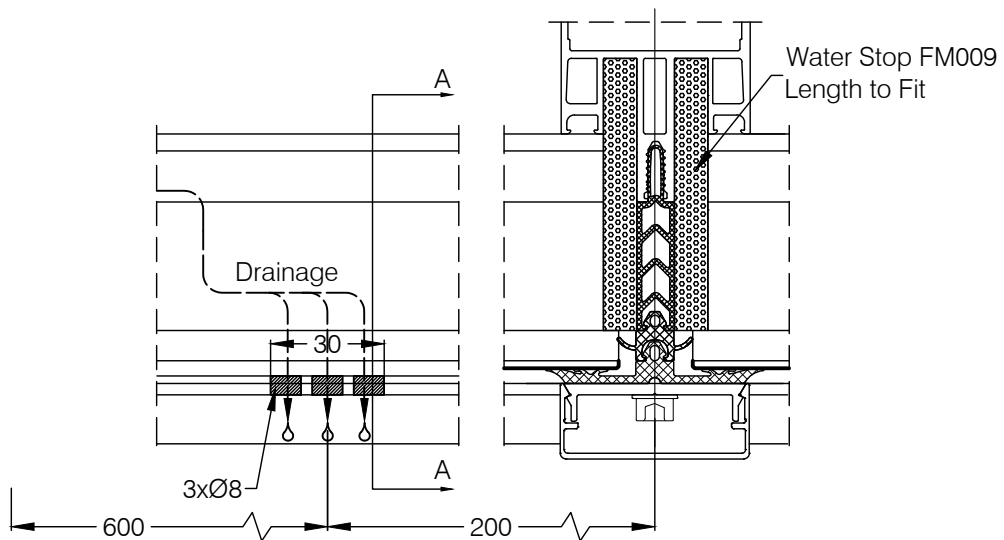
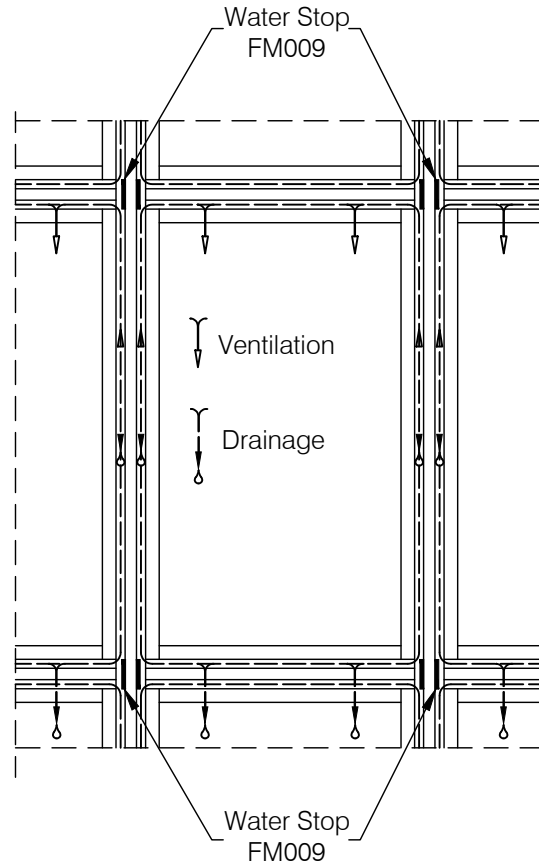
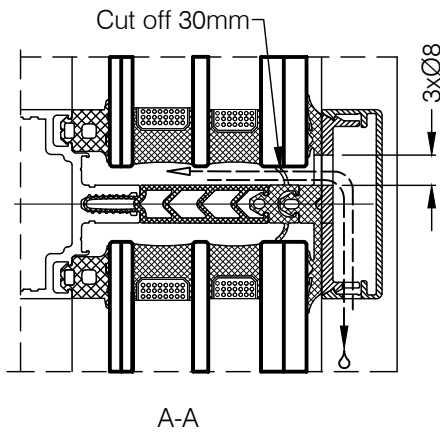
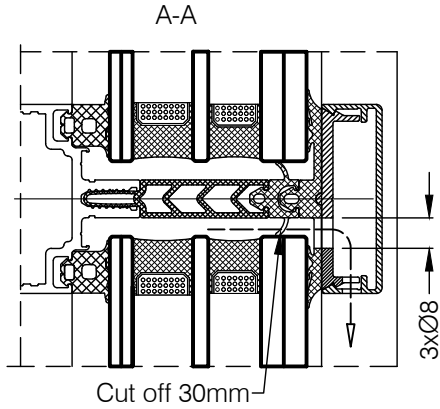

Copyright and ownership of this drawing is vested in EFT, Euro Facade Systems Ltd, whose prior written consent is required for its use, reproduction or for publication to any third party. All other rights reserved. Subject to modifications.



comar
ARCHITECTURAL ALUMINIUM SYSTEMS

Changes reserved
Sous reserve de modifications
Änderungen vorbehalten

Issue: 05
Date: 10-16

Sealing

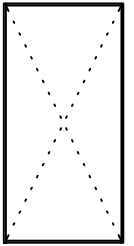

7.61

Copyright and ownership of this drawing is vested in EFT, Euro Facade Systems Ltd, whose prior written consent is required for its use, reproduction or for publication to any third party. All other rights reserved. Subject to modifications.

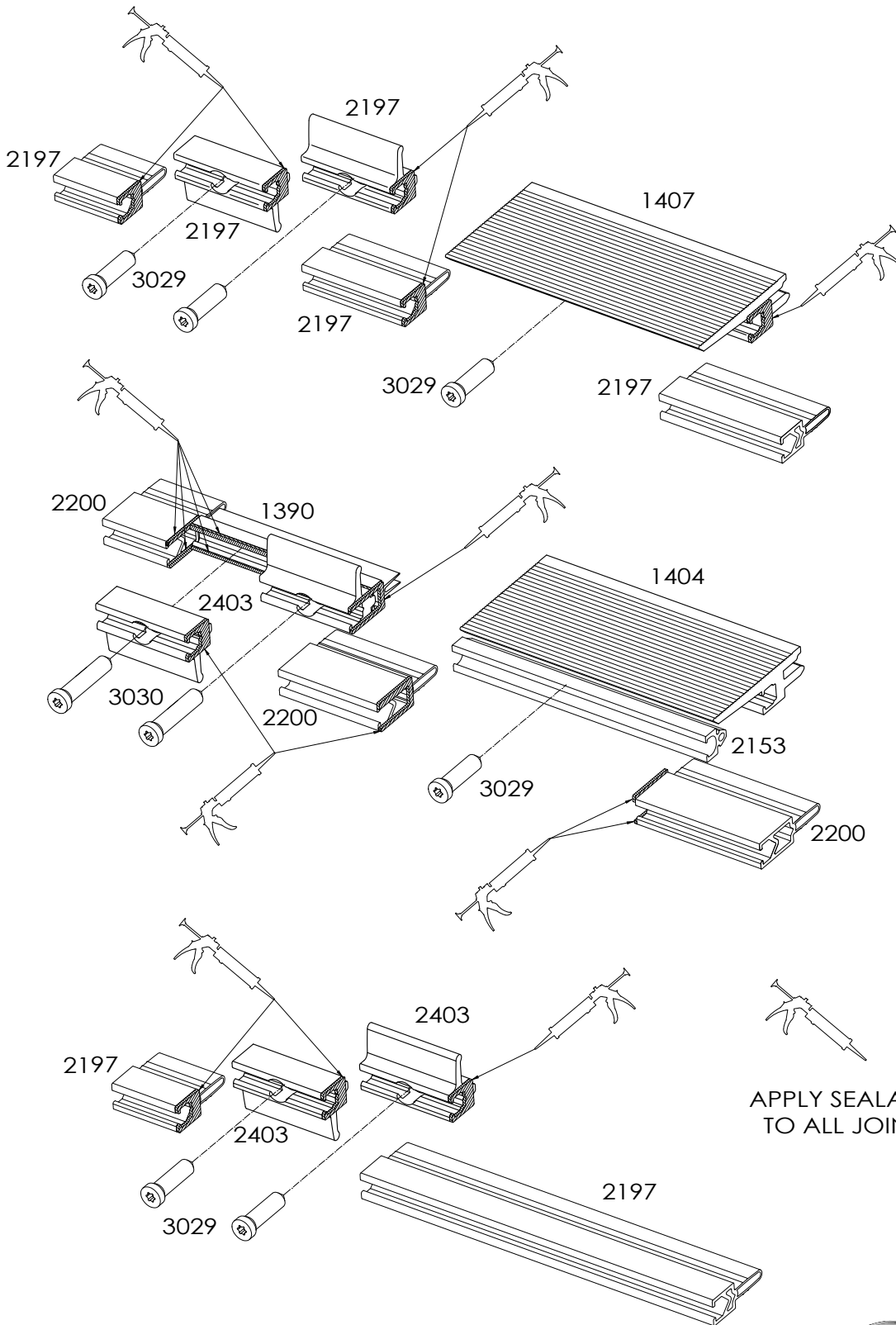

APPLY SEALANT
TO ALL JOINT

Changes reserved
Sous reserve de modifications
Änderungen vorbehalten

Issue: 05
Date: 10-16

Installation

7

Comar 6EFT

Transom drainage diverter

Transom drainage diverter 2025 to be used on 4 sided SG faceted screens and any 4sided SG corners.

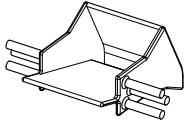
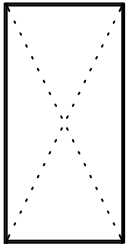

2025

7.62

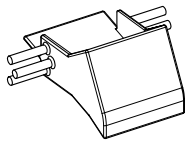

Fabricators Guide

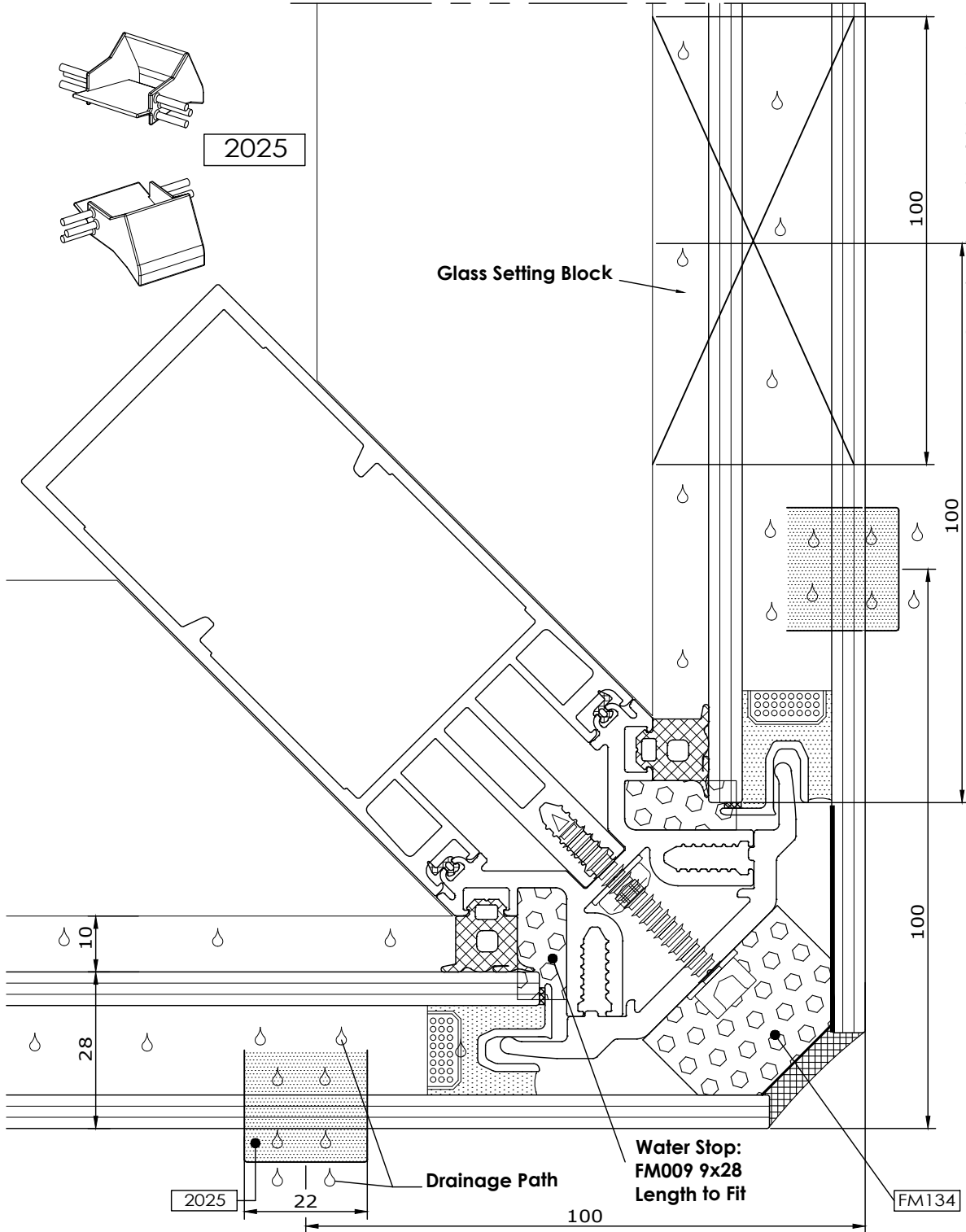

Copyright and ownership of this drawing is vested in EFT, Euro Facade Systems Ltd, whose prior written consent is required for its use, reproduction or for publication to any third party. All other rights reserved. Subject to modifications.



comar
ARCHITECTURAL ALUMINIUM SYSTEMS

Changes reserved
Sous reserve de modifications
Änderungen vorbehalten

Issue: 05
Date: 10-16

Transom drainage diverter

Transom drainage diverter 2025 to be used on 4sided SG faceted screens and any 4 sided SG corners.

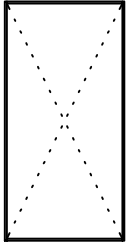

7.63

Copyright and ownership of this drawing is vested in EFT, Euro Facade Systems Ltd, whose prior written consent is required for its use, reproduction or for publication to any third party. All other rights reserved. Subject to modifications.

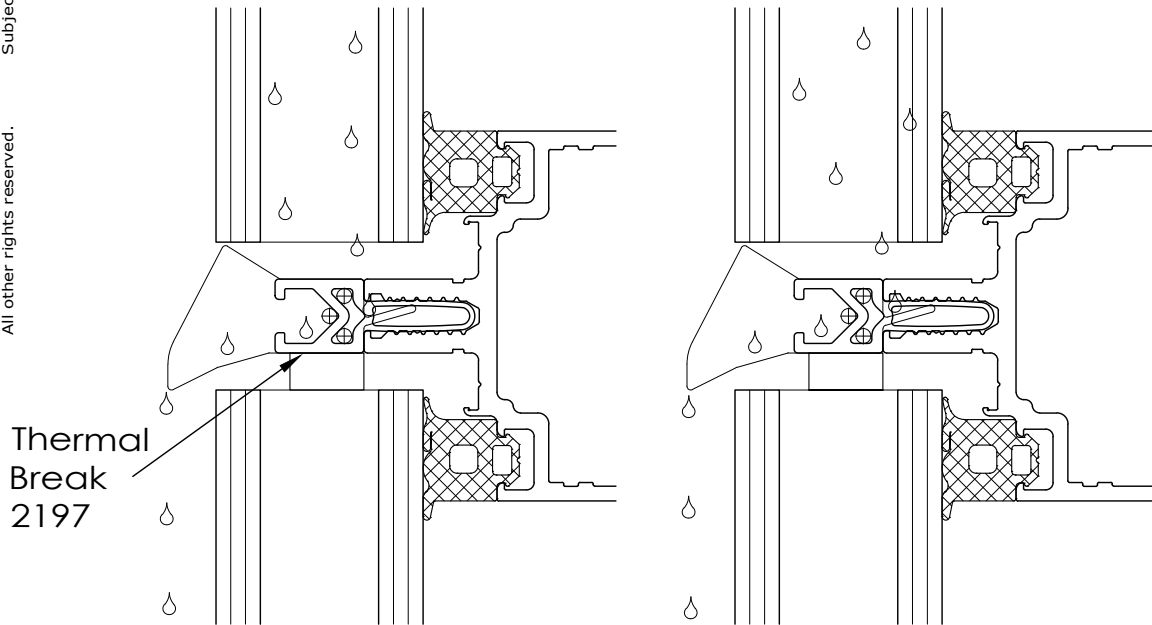

Thermal Break 2197

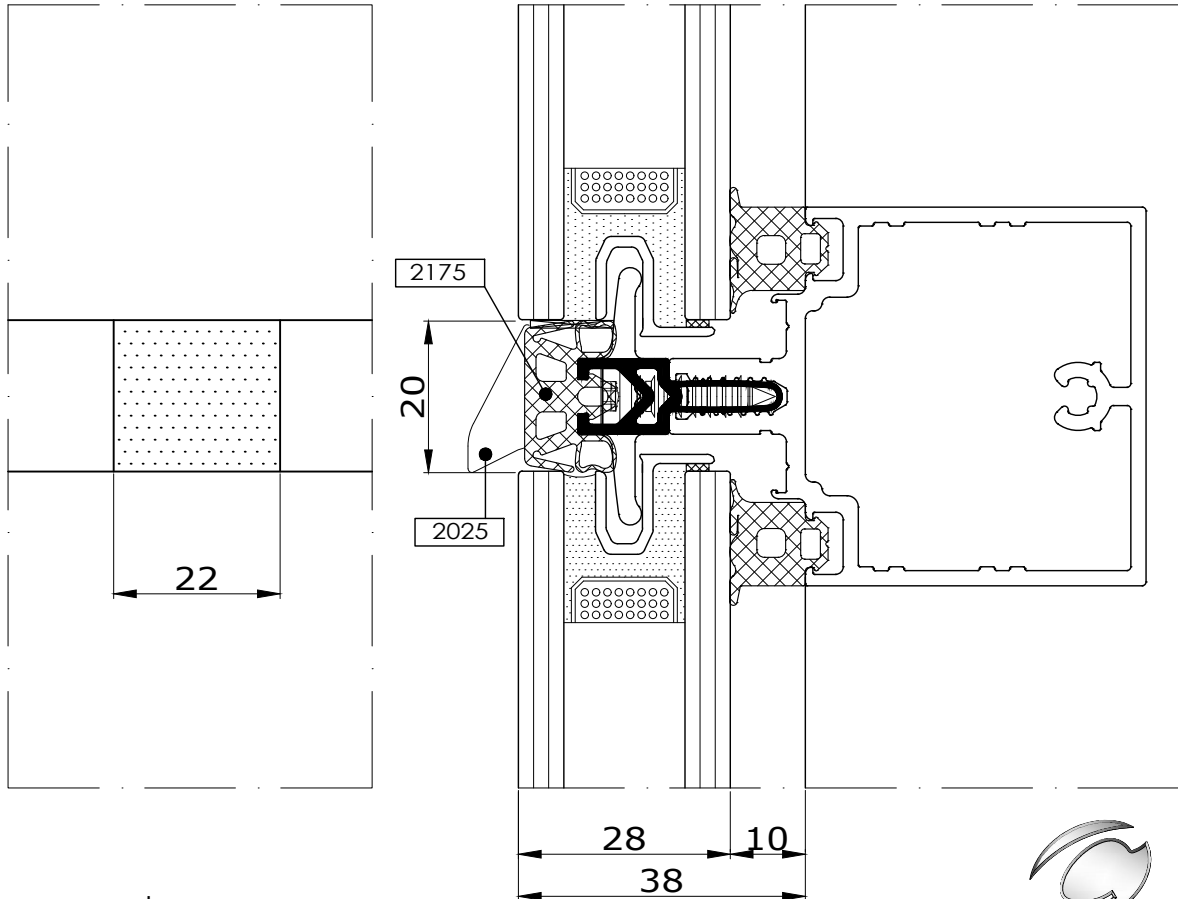

Fabricators Guide

Changes reserved
 Sous reserve de modifications
 Änderungen vorbehalten

Issue: 05
 Date : 10-16

Installation

7

Comar 6EFT

Butyl tape application

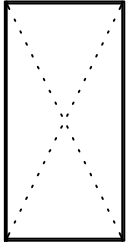

7.64

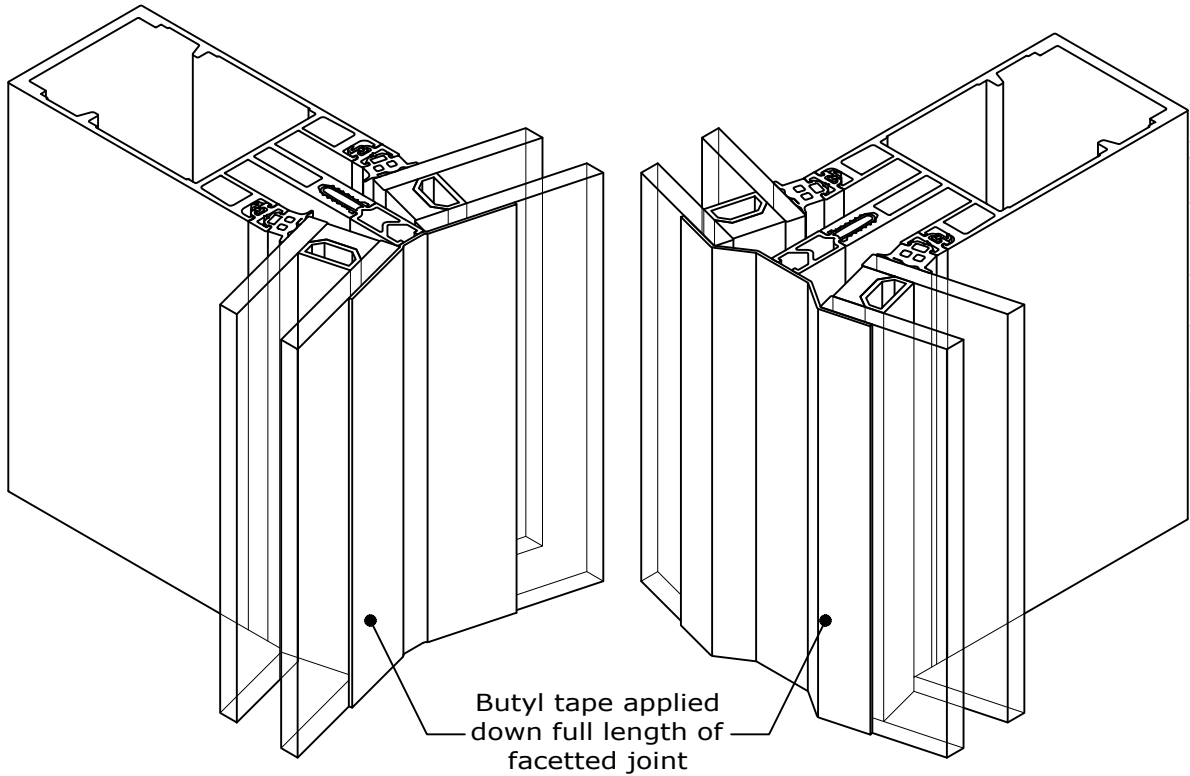

Butyl tape 6001 or 6002 to be installed full height of the mullion down any faceted angle joint to be covered by a pressure plate & cover cap.

Punched & drilled holes for pressure plate screws, drainage diverters and pressure equalization.

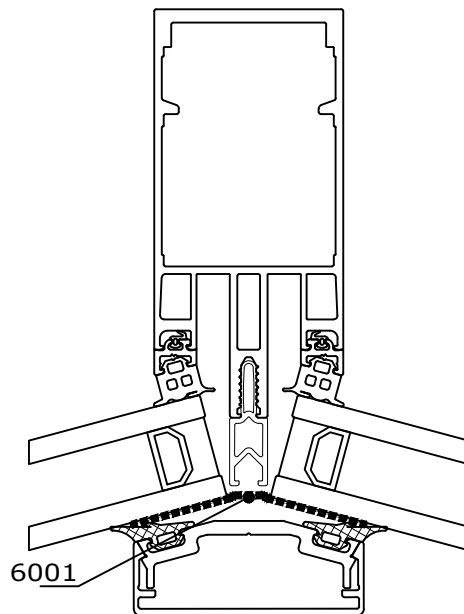
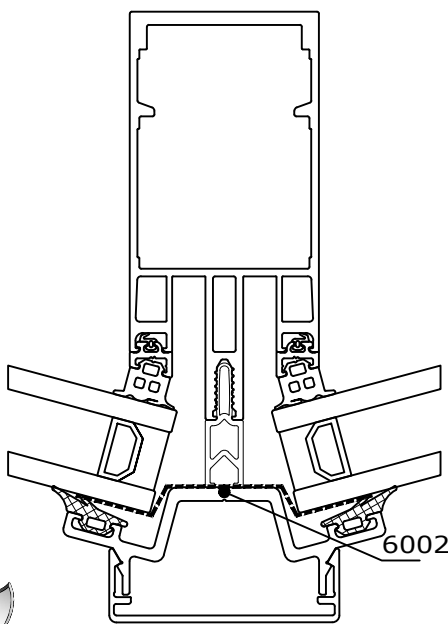

comar
ARCHITECTURAL ALUMINIUM SYSTEMS

Changes reserved
Sous reserve de modifications
Änderungen vorbehalten

Issue: 05
Date: 10-16

Copyright and ownership of this drawing is vested in EFT, Euro Facade Systems Ltd, whose prior written consent is required for its use, reproduction or for publication to any third party. All other rights reserved. Subject to modifications.

Copyright and ownership of this drawing is vested in EFT, Euro Facade Systems Ltd, whose prior written consent is required for its use, reproduction or for publication to any third party. All other rights reserved. Subject to modifications.

Single gasket installation

7

Installation Comar 6EFT

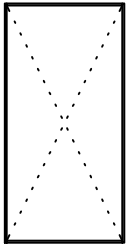

7.65

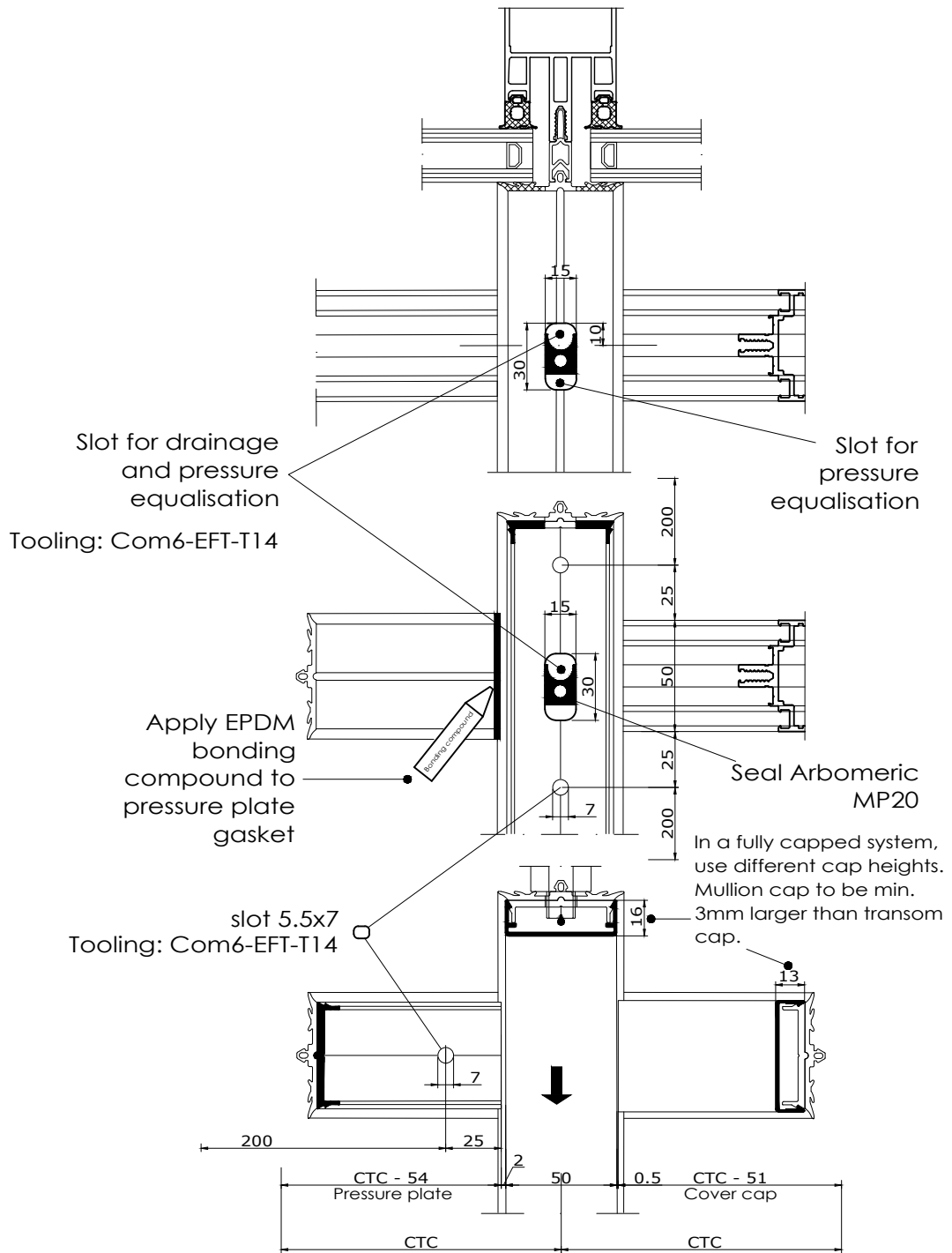

↓
= thermal expansion

Changes reserved
Sous reserve de modifications
Änderungen vorbehalten

Issue: 05
Date: 10-16

Installation

7

Comar 6EFT

Draining horizontal

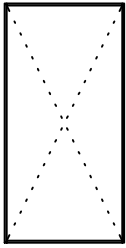

7.66

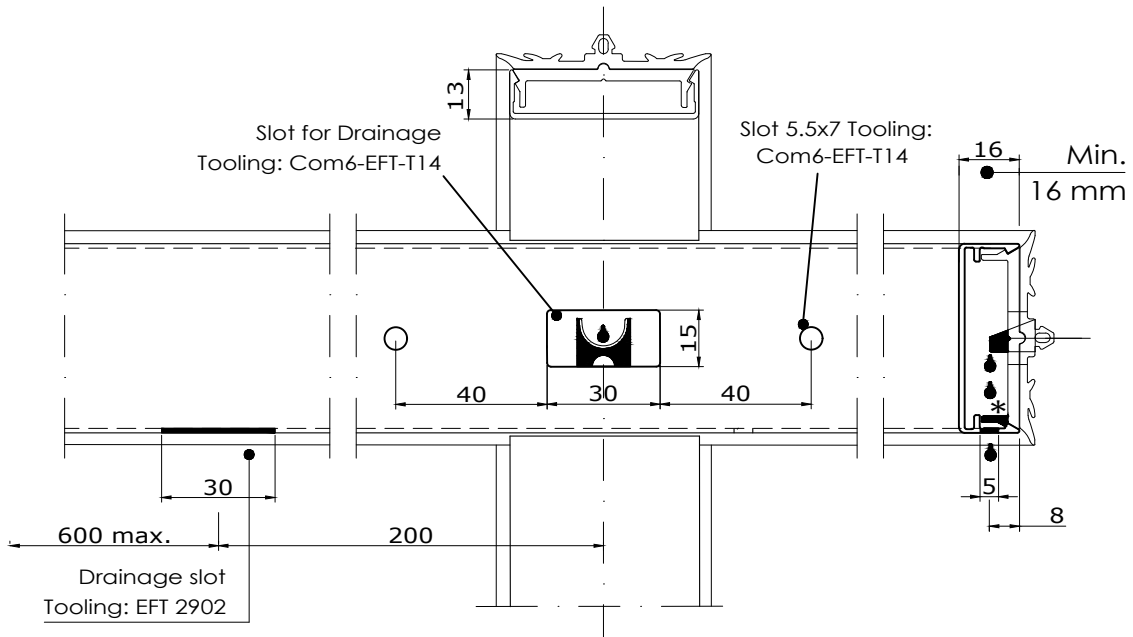

Copyright and ownership of this drawing is vested in EFT, Euro Facade Systems Ltd, whose prior written consent is required for its use, reproduction or for publication to any third party. All other rights reserved. Subject to modifications.

Fabricators Guide

FIXING LARGE COVER CAPS

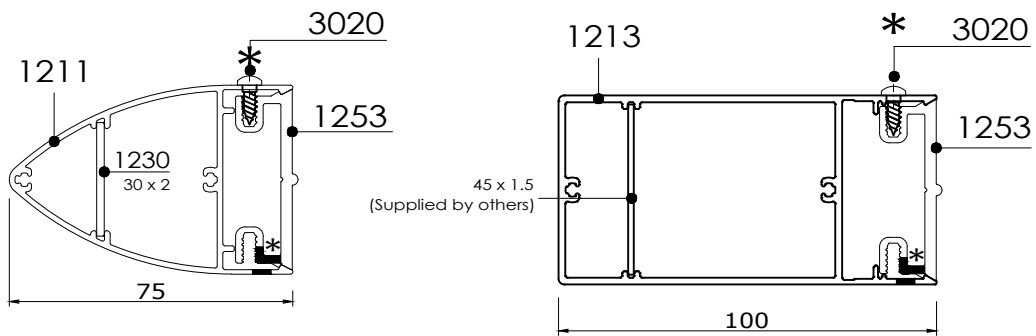

* Secure large sized cover caps with pan head screw 3020 (3.5x9) e.g. underneath the vertical cover cap. C.T.C 1500mm max.

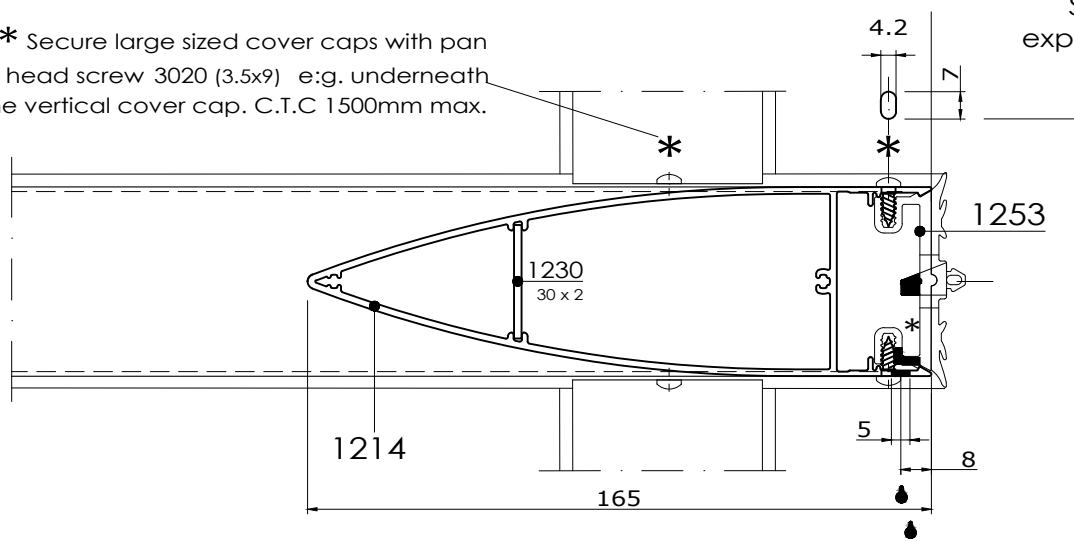

comar
ARCHITECTURAL ALUMINIUM SYSTEMS

Changes reserved
Sous reserve de modifications
Änderungen vorbehalten

Issue: 05
Date: 10-16

Copyright and ownership of this drawing is vested in EFT, Euro Facade Systems Ltd, whose prior written consent is required for its use, reproduction or for publication to any third party. All other rights reserved. Subject to modifications.

7

Installation

Comar 6EFT

Draining large heights
Fixing vertical cover caps

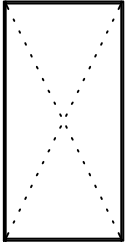

7.67

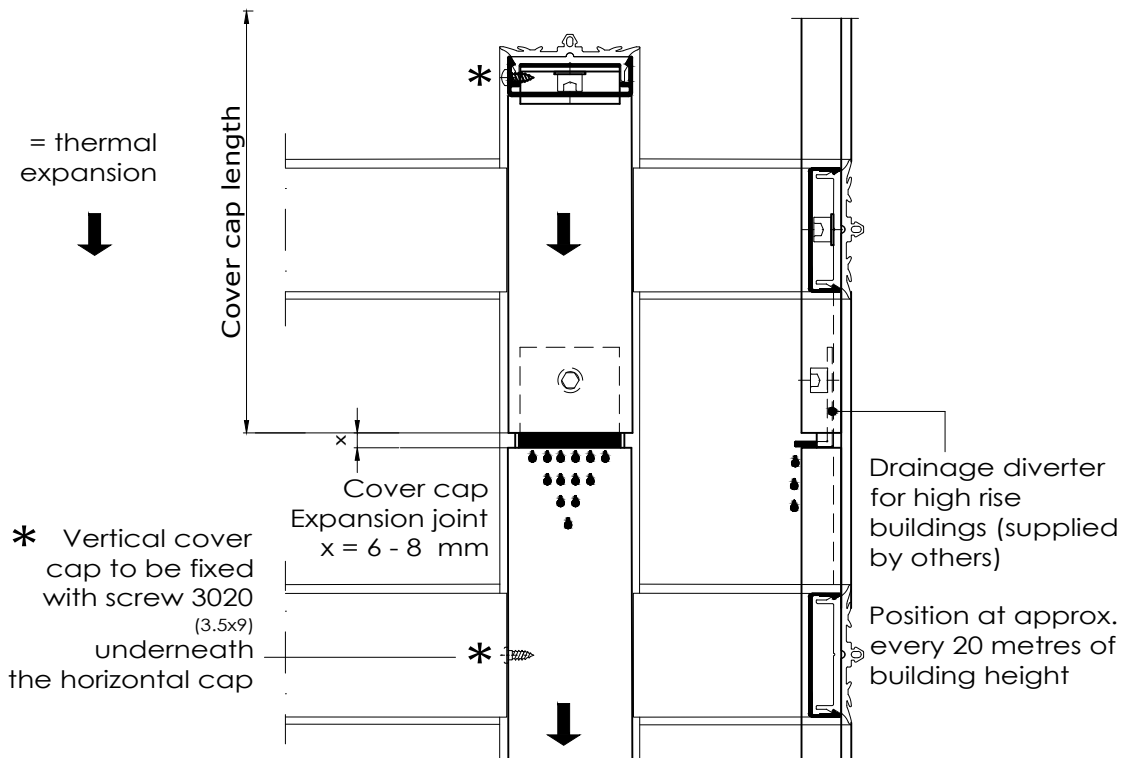
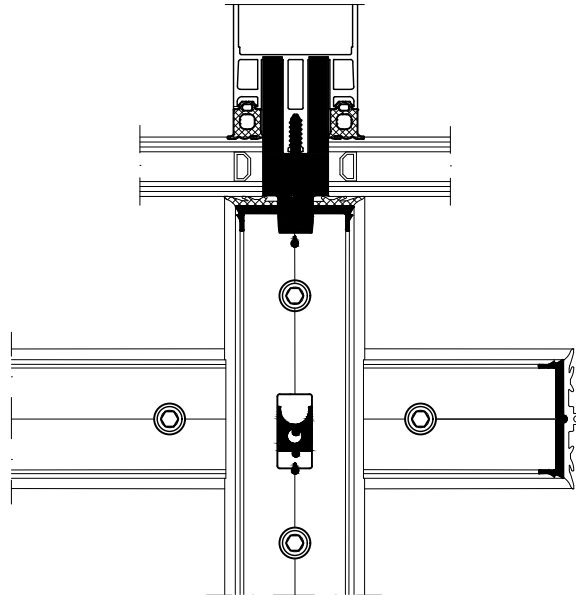

Changes reserved
Sous reserve de modifications
Änderungen vorbehalten

Issue: 05
Date: 10-16

Installation

7

Comar 6EFT

Silicone seal & bond breaker tape application

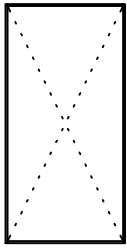

7.68

Fabricators Guide

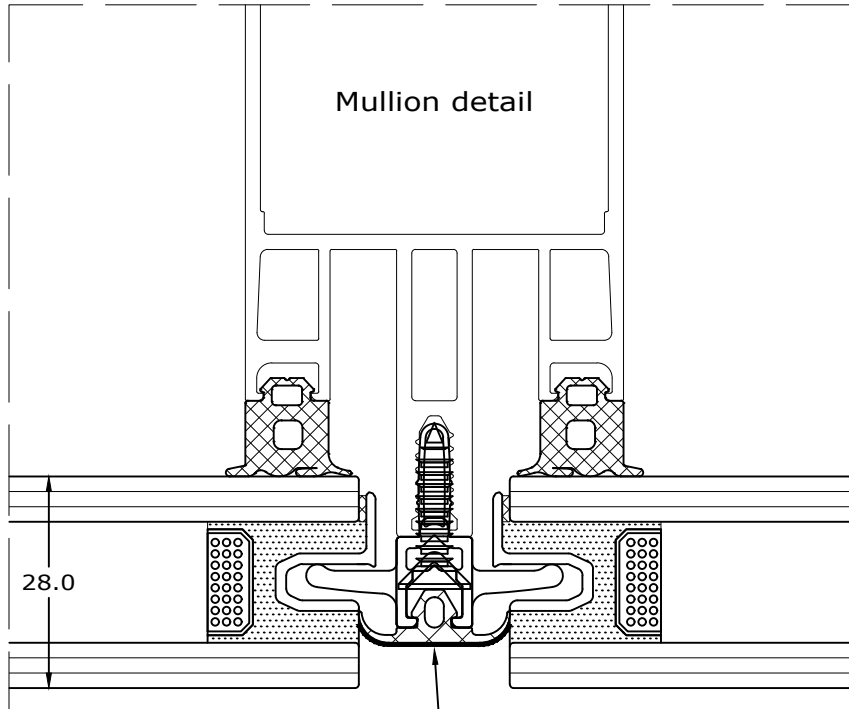

Any edge of gasket that will be exposed to external silicone seal must have bond breaker tape applied to its surface to prevent a three way seal

It is the silicone installers responsibility to supply and apply a suitable bond breaker tape and silicone seal.

A warranty on the silicone seal should be obtained from the silicone installer company.

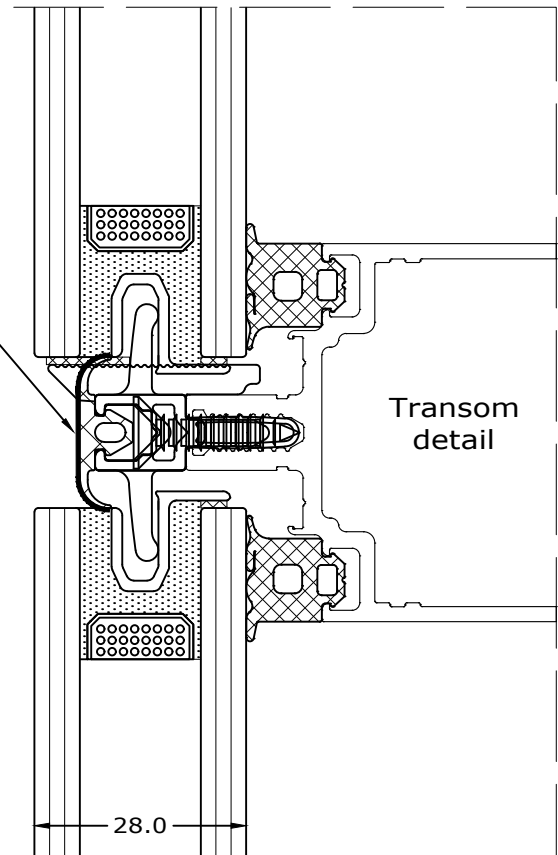

Copyright and ownership of this drawing is vested in EFT, Euro Facade Systems Ltd, whose prior written consent is required for its use, reproduction or for publication to any third party. All other rights reserved. Subject to modifications.



comar
ARCHITECTURAL ALUMINIUM SYSTEMS

Changes reserved
Sous reserve de modifications
Änderungen vorbehalten

Issue: 05
Date: 10-16