

Copyright and ownership of this drawing is vested in EFT,
Euro Facade Systems Ltd, whose prior written consent is required
for its use, reproduction or for publication to any third party.
All other rights reserved. Subject to modifications.

2sided SGH

2

Typical details

Comar 6EFT

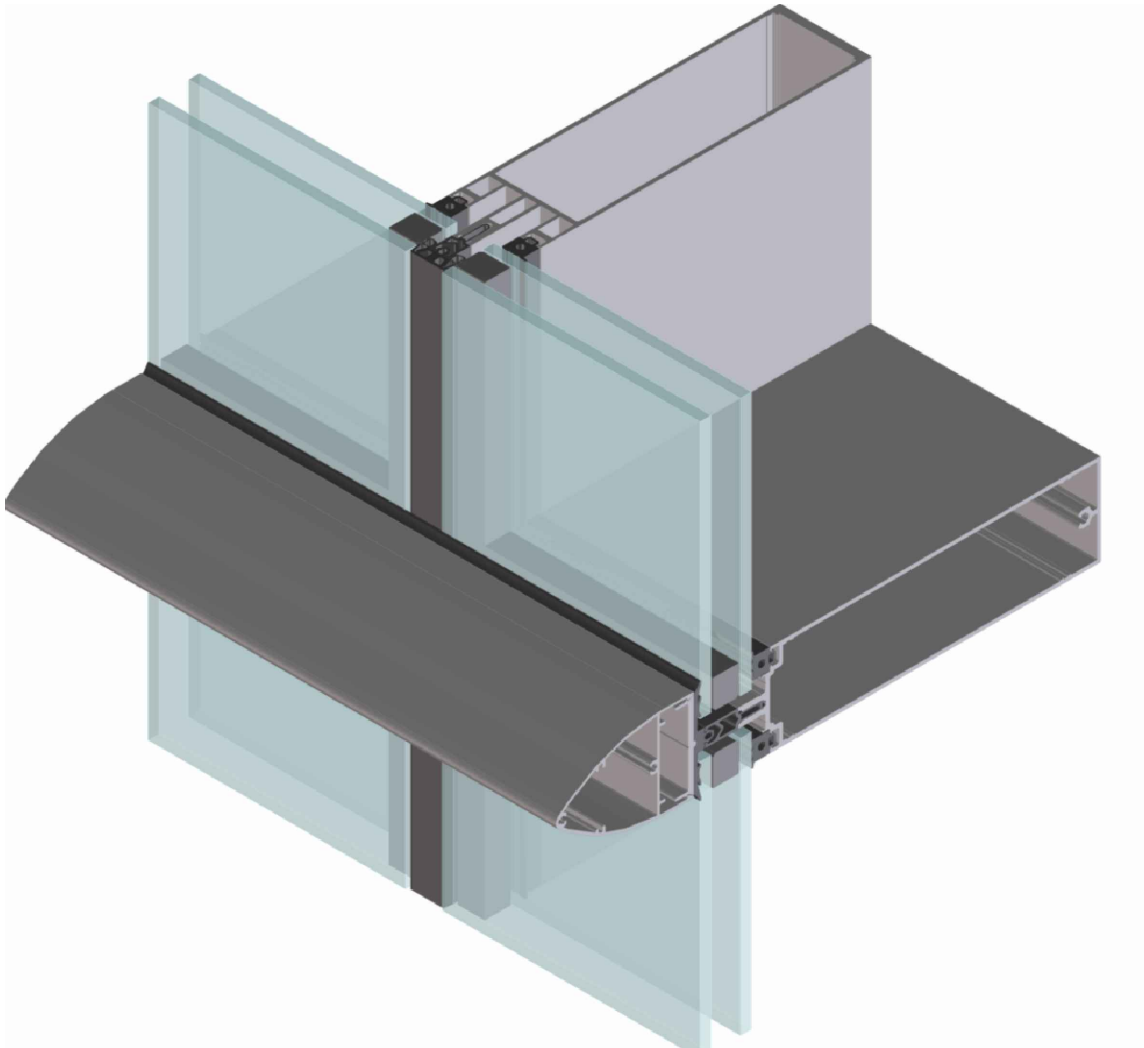
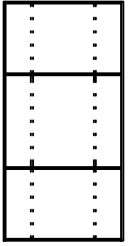

Fabricators Guide

Changes reserved
Sous reserve de modifications
Änderungen vorbehalten

Issue: 05
Date: 10 -16

Introduction

Comar 6EFT 2Sided SGH

Comar 6EFT 2Sided Horizontal Curtain Wall System

enables the construction of attractive 2sided structural glazed curtain walling, with the benefits of slim vertical sightlines or, by using different horizontal cover cap design features.

This thermally insulated system consists of standard 50mm profiles, bespoke profiles are available upon request.

Specification Summary

Comar 6EFT 2Sided Horizontal Curtain Walling is a mullion drained, thermally broken curtain wall system, which consists of 50mm mullions and transoms suitable for facades.

The external vertical sightline (joint seal) is 20mm. The joint seal can be made from EPDM, compatible with most silicone sealants or this can be made out of silicone sealant.

Various cover caps are available for this system. The smallest sightline can be achieved using a 50 mm wide double chamfered cap to provide a visible front face of 16mm

Glazing

The system is externally glazed. Glazing should conform to the requirements of BS 6262 for thickness, type, wind resistance, safety and security.

Drainage

The system is mullion drained, achieved by meeting the requirements of "ventilated and drained glazing system" as specified in BS 6262

Thermal Insulation

Class 2.1 in accordance with DIN 4108 (2.0-2.8 W/m²K) or EN ISO 10077 - 1

The thermal transmittance (Uf) W/m²K, is depending on the insulator strip, calculated as per EN ISO 10077 - 1.

Comparable with class 2.1 DIN 4108 - 4 Table 3

Sound Insulation

Dependant on the glass specification, generally the curtain wall framing reduces the figure by 2dB (A).

Materials

The system is constructed from extruded aluminium profiles, using alloy 6063 complying to the requirements of BS 1474.

The thermal barrier system is achieved by means of PVC/PP extrusion

Construction

Any instructions regarding the manufacture and installation of the system must be strictly adhered to.

Weathering

Glazing vision strips are made of EPDM conforming to BS 4255 Part 1

Performance / exposure category

The system will achieve the following criteria when manufactured, installed and glazed to EFT recommended procedures, in accordance with CWCT approved testing methods.

Classification

Air permeability: BS EN 12152 - Class AE 750

Water tightness: BS EN 12154 - Class RE 750

Wind resistance: BS EN 13116 -
2400 Pa design - 3600 Pa safety

2400Pa (Pascal's) is dependant upon correct mullion and transom selection to suit span and spacing by project.

Size limitations

The size limitations of the system depends mainly on the mullion/transom members used to suit the span, spacing and wind/dead loads, which are specific for each individual project. Please refer to Comar's Technical Office for advise.



Typical details

2

Comar 6EFT

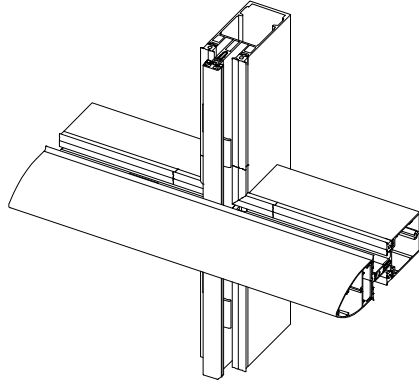
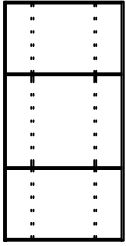

Typical Exploded Detail Horizontal cover cap (2sided SGH)

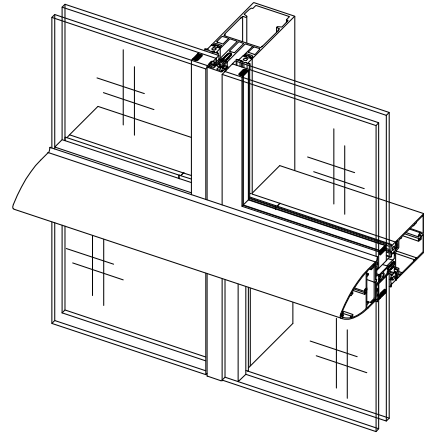

Details:

1. One substructure for all curtain wall types, Fully Capped, 2sided SGH, 2sided SGV & 4sided SG.
2. Controlled drainage system (mullion drained) drainage diverter/cover.
3. Thermally broken.
4. Mullion-Transom step-cut & sealed by EPDM moulding.
5. Ladder (unit) construction or stick build.
6. Moulded EPDM corners available.
7. Continuous pressure plate gasket.
8. Glazing clamping system into DG unit.
9. Continuous pressure plate gasket.

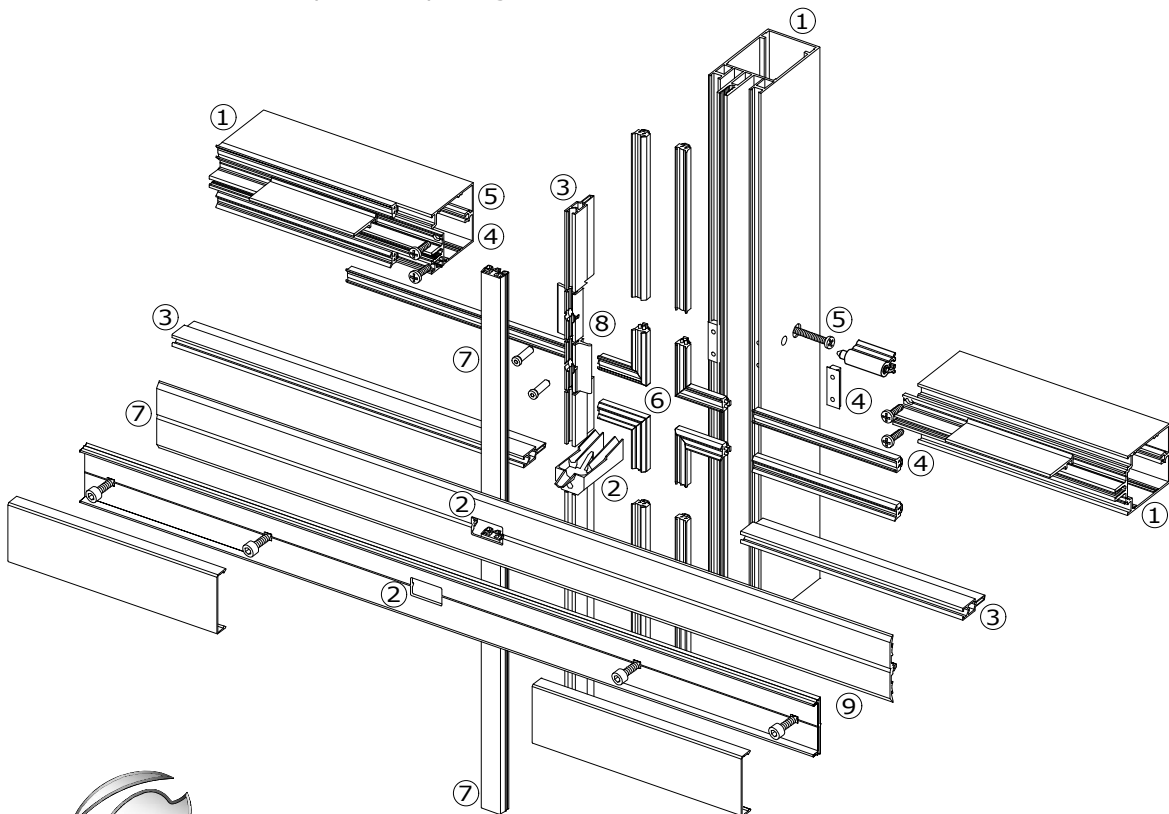

Fabrications Guide

Copyright and ownership of this drawing is vested in EFT, Euro Facade Systems Ltd, whose prior written consent is required for its use, reproduction or for publication to any third party. All other rights reserved. Subject to modifications.



comar
ARCHITECTURAL ALUMINIUM SYSTEMS

Changes reserved
Sous reserve de modifications
Änderungen vorbehalten

Issue: 05
Date: 10 -16

Copyright and ownership of this drawing is vested in EFT, Euro Facade Systems Ltd, whose prior written consent is required for its use, reproduction or for publication to any third party. All other rights reserved.

2sided SGH

2

Typical details

Comar 6EFT

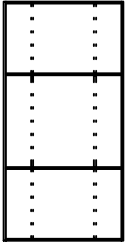

Horizontal cover cap / Vertical EPDM gasket or silicone sealant

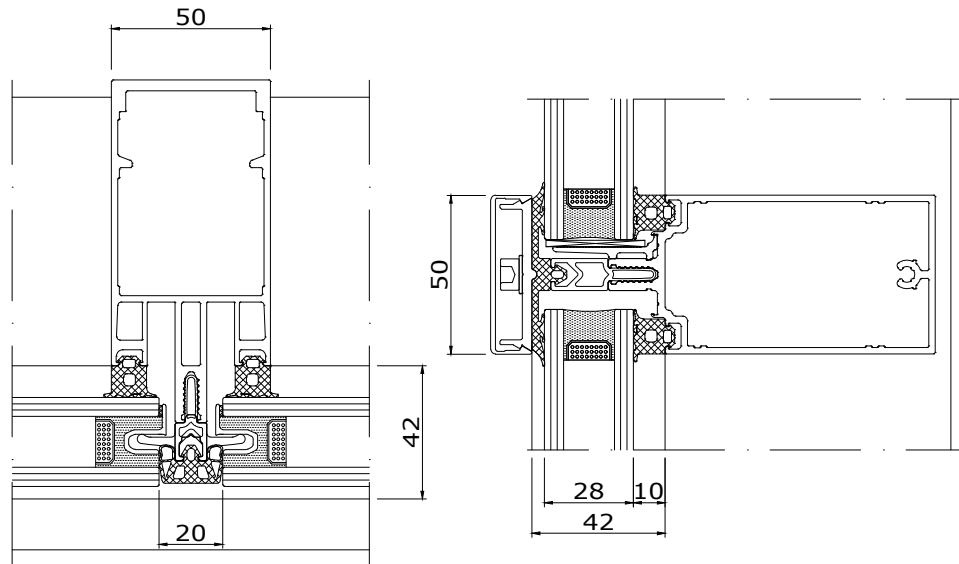

2.36

Including Comar 6EFT Concealed Vent

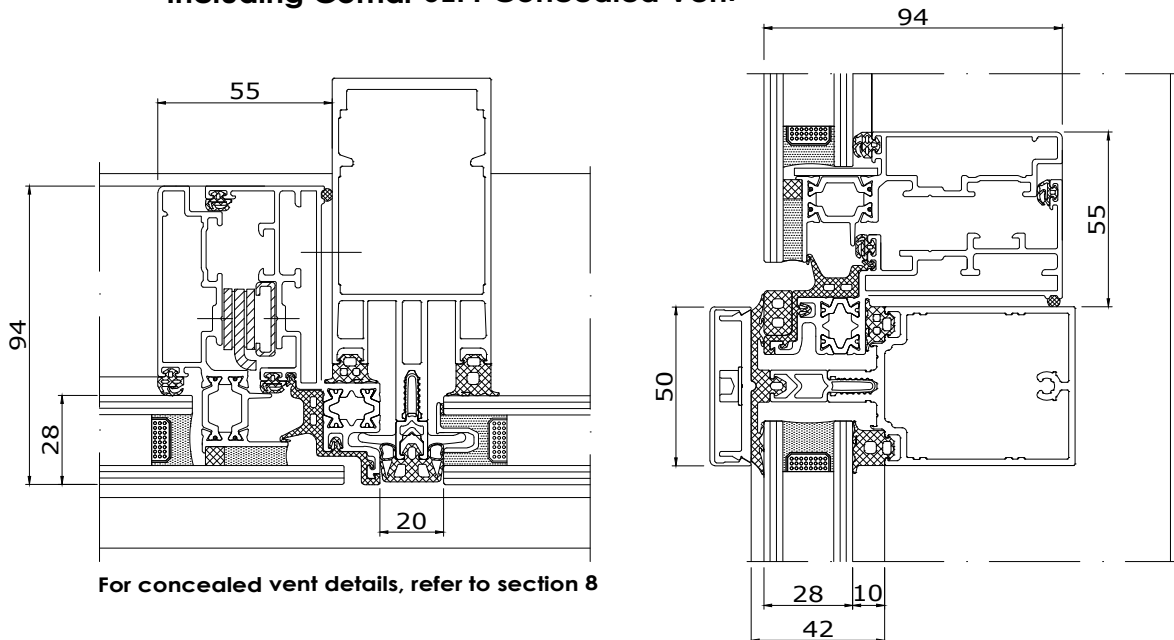

For concealed vent details, refer to section 8

Fabricators Guide

Changes reserved
 Sous reserve de modifications
 Änderungen vorbehalten

Issue: 05
 Date: 10 -16

Typical details

2

Comar 6EFT

Mullion detail Gasket seal

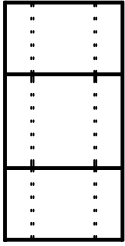

2.37

Fabricators Guide

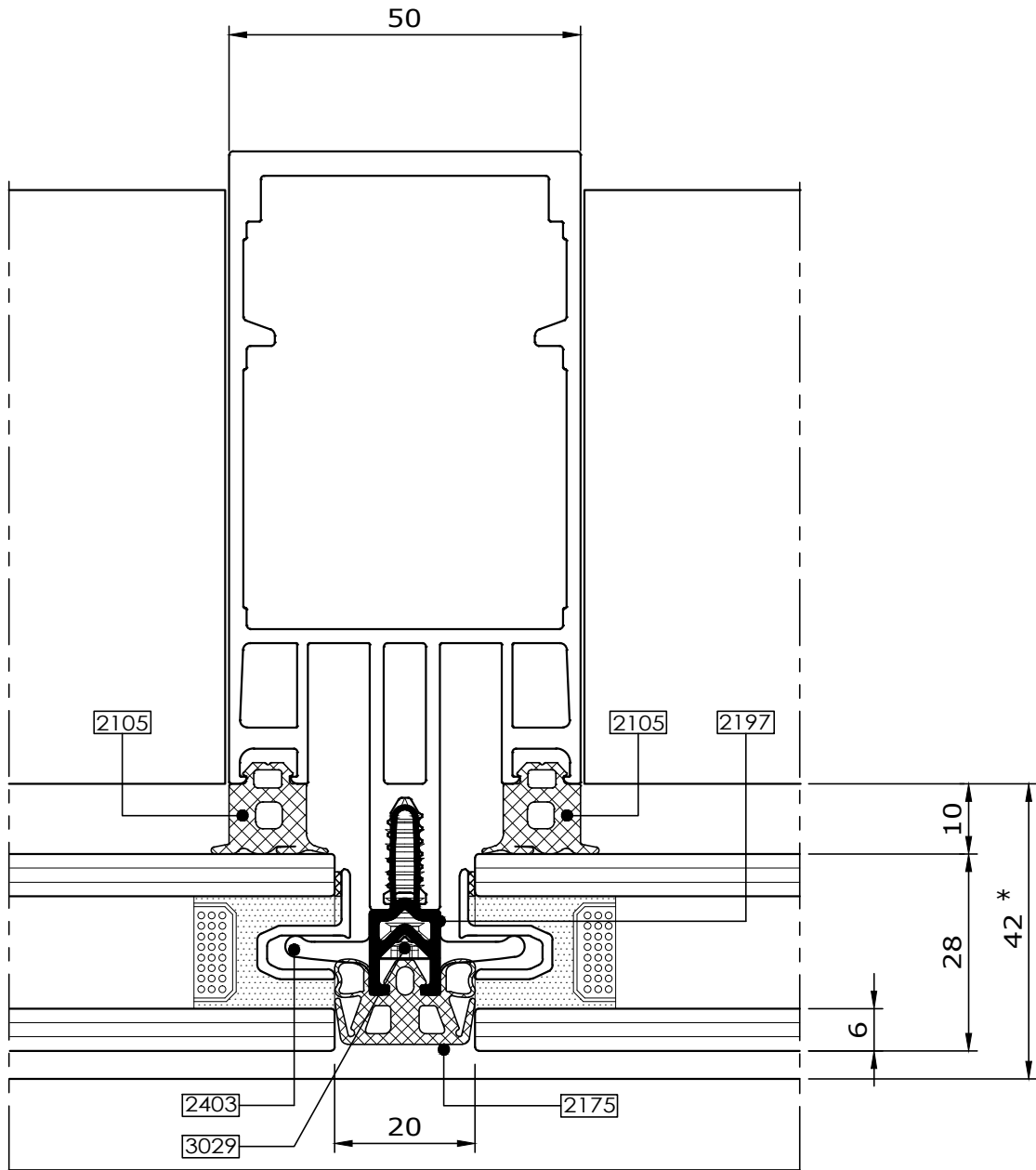

* Refer to Glazing Chart for glazing options

2

Typical details

Comar 6EFT

Transom detail

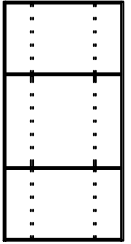

Copyright and ownership of this drawing is vested in EFT, Euro Facade Systems Ltd, whose prior written consent is required for its use, reproduction or for publication to any third party. All other rights reserved. Subject to modifications.

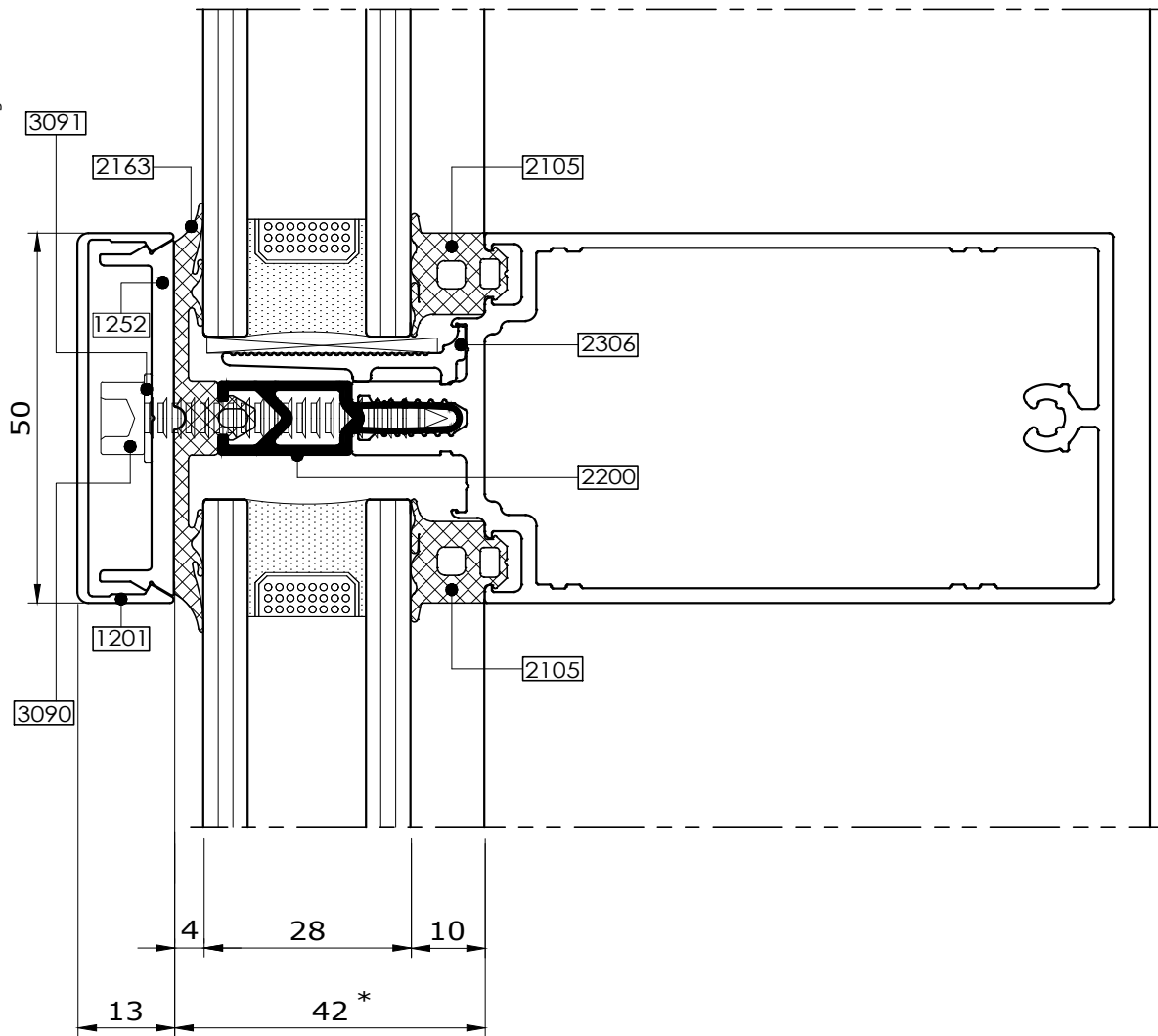

* Refer to Glazing Chart for glazing options

Changes reserved
Sous reserve de modifications
Änderungen vorbehalten

Issue: 05
Date: 10 -16

Typical details

2

Comar 6EFT

Mullion Detail Gasket seal

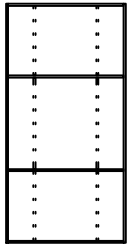

2.38.1

Fabricators Guide

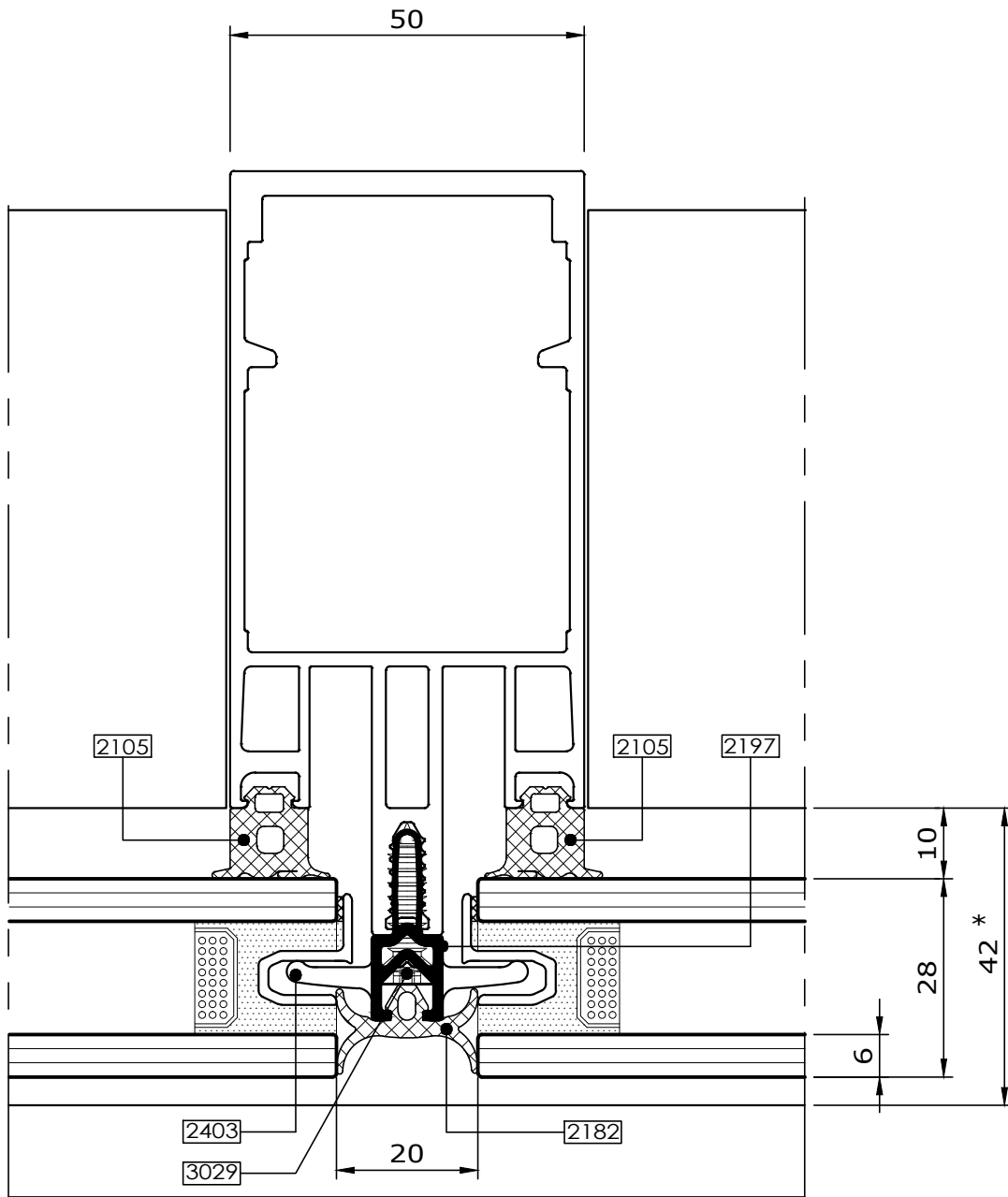

* Refer to Glazing Chart for glazing options

Copyright and ownership of this drawing is vested in EFT, Euro Facade Systems Ltd, whose prior written consent is required for its use, reproduction or for publication to any third party. All other rights reserved. Subject to modifications.

Copyright and ownership of this drawing is vested in EFT, Euro Facade Systems Ltd, whose prior written consent is required for its use, reproduction or for publication to any third party. All other rights reserved.

Mullion detail Silicone seal

2

Typical details

Comar 6EFT

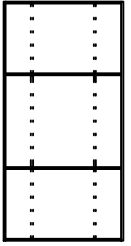

2.39

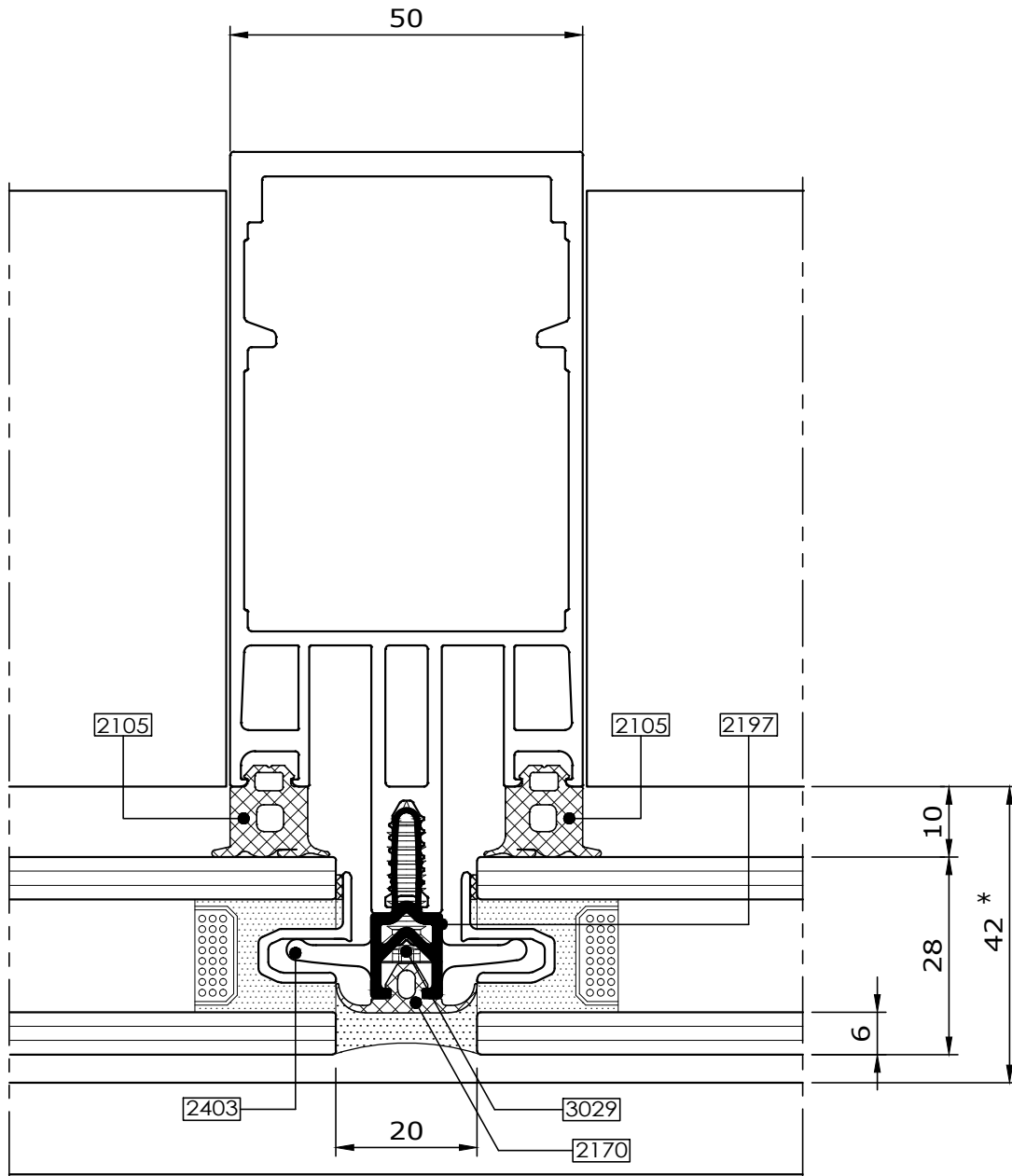

Fabrications Guide

* Refer to Glazing Chart for glazing options

Changes reserved
Sous reserve de modifications
Änderungen vorbehalten

Issue: 05
Date: 10 -16

Typical details

2

Comar 6EFT

Transom detail

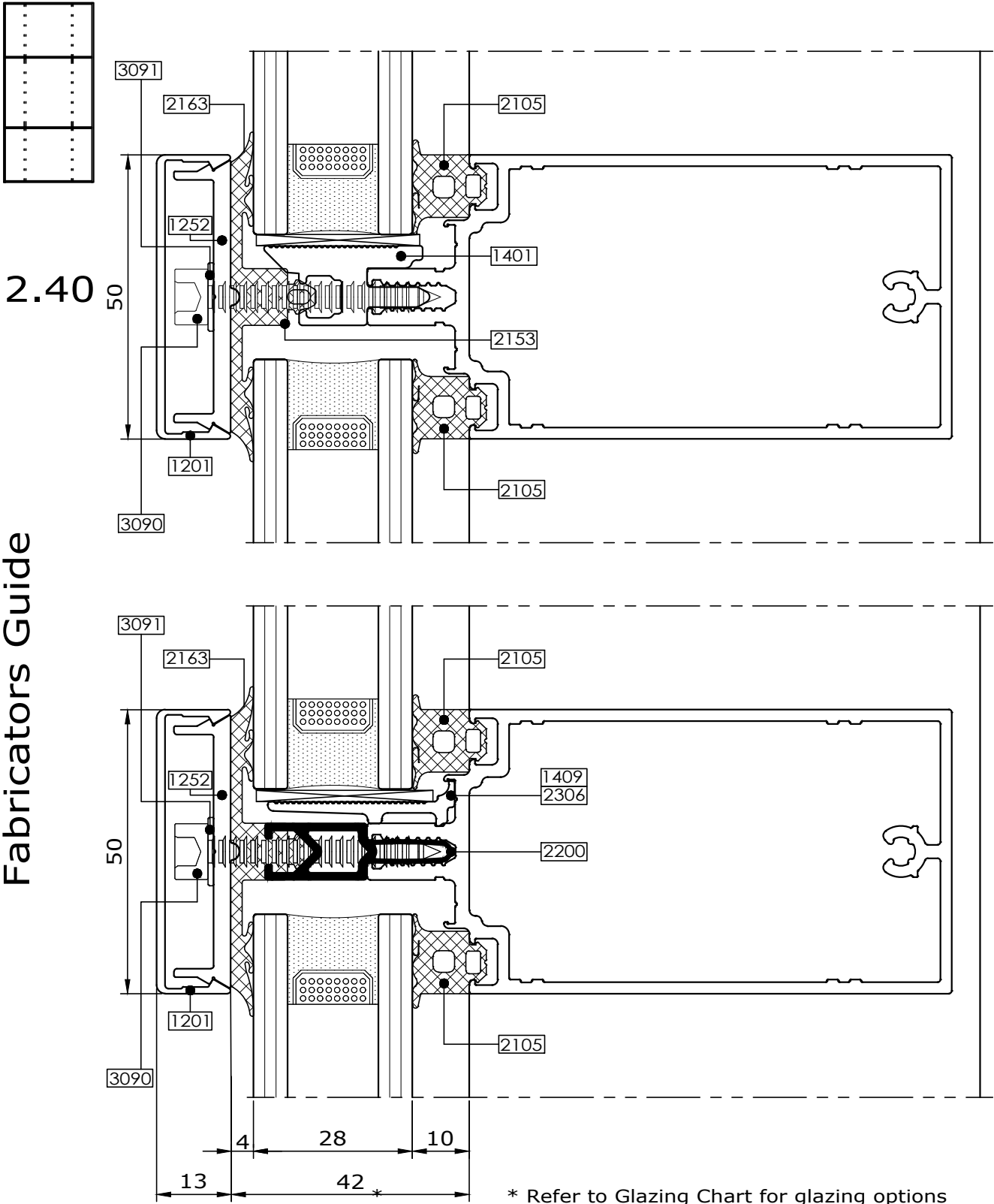

Copyright and ownership of this drawing is vested in EFT, Euro Facade Systems Ltd, whose prior written consent is required for its use, reproduction or for publication to any third party. All other rights reserved. Subject to modifications.

Fabricators Guide

2

Typical details

Mullion corner detail

Comar 6EFT

2.41

Copyright and ownership of this drawing is vested in EFT, Euro Facade Systems Ltd, whose prior written consent is required for its use, reproduction or for publication to any third party. All other rights reserved. Subject to modifications.

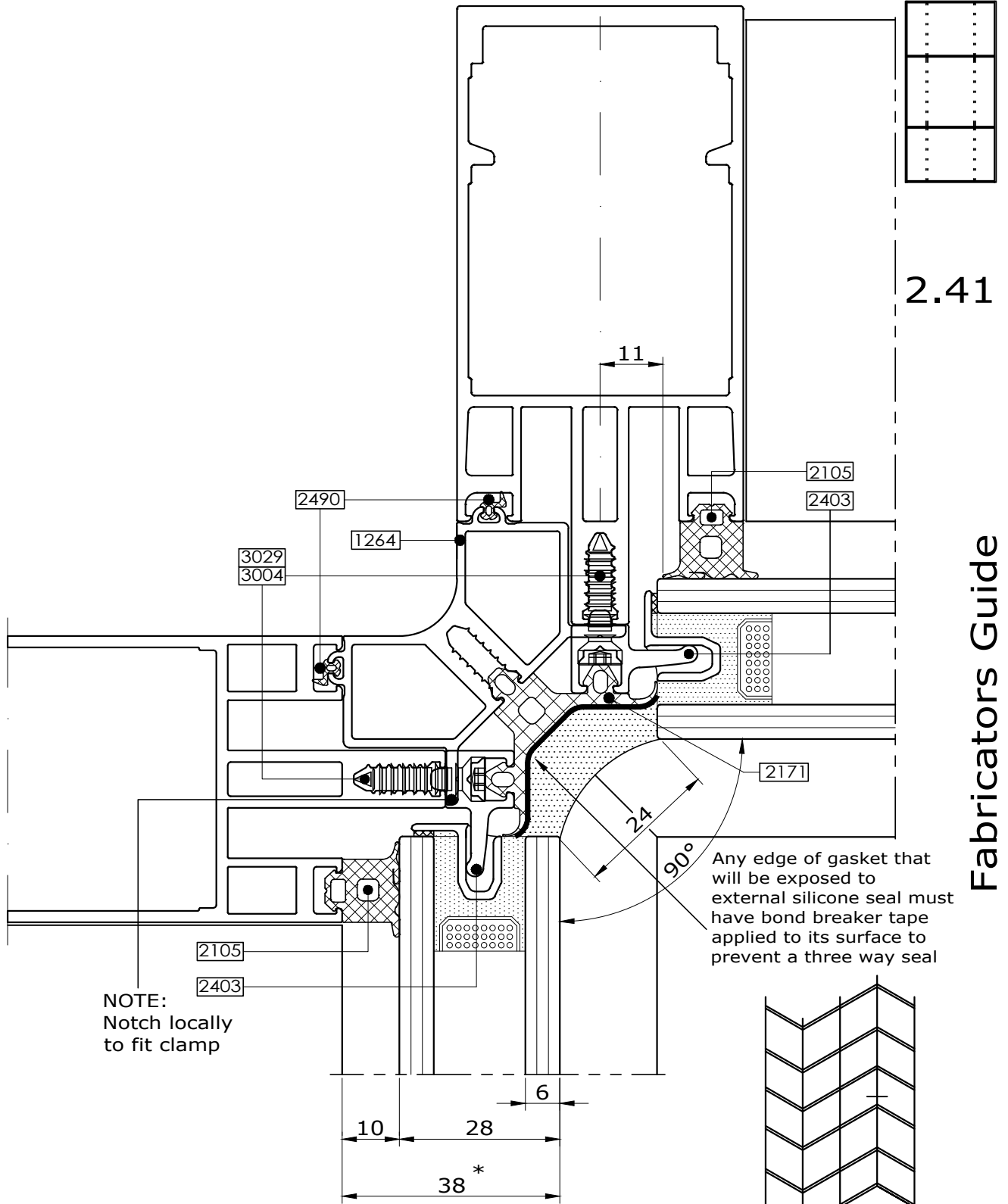

Any edge of gasket that will be exposed to external silicone seal must have bond breaker tape applied to its surface to prevent a three way seal

* Refer to Glazing Chart for glazing options

Fabricators Guide

Changes reserved
Sous reserve de modifications
Änderungen vorbehalten

Issue: 05
Date: 10 -16



45° mullion corner detail

Comar 6EFT

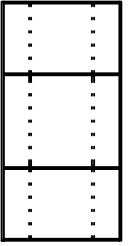

2.42

Copyright and ownership of this drawing is vested in EFT, Euro Facade Systems Ltd, whose prior written consent is required for its use, reproduction or for publication to any third party. All other rights reserved. Subject to modifications.

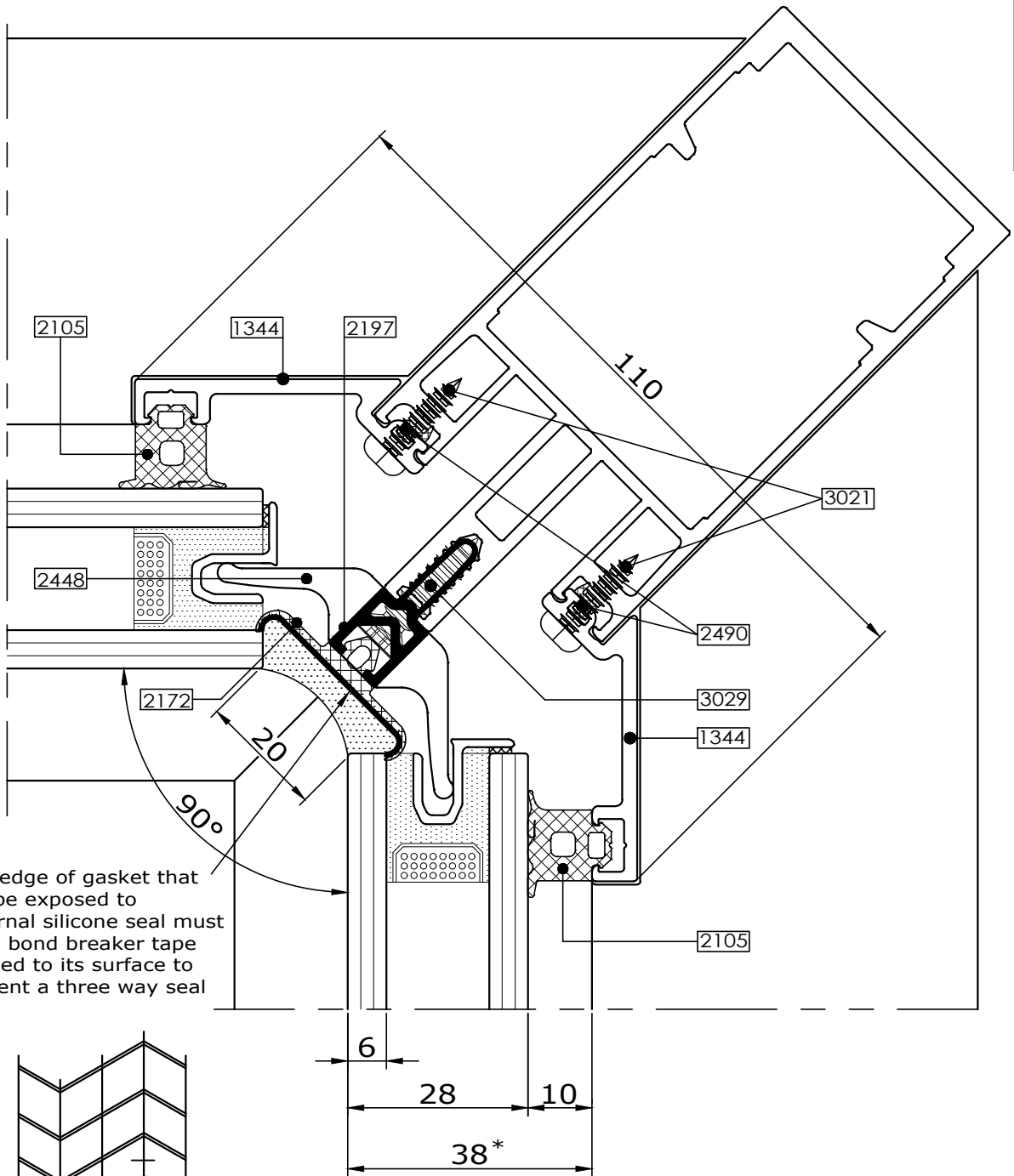

* Refer to Glazing Chart for glazing options

Changes reserved
 Sous reserve de modifications
 Änderungen vorbehalten

Issue: 05
 Date :10 -16

45° corner detail

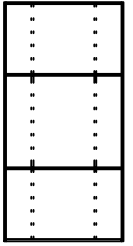

2.43

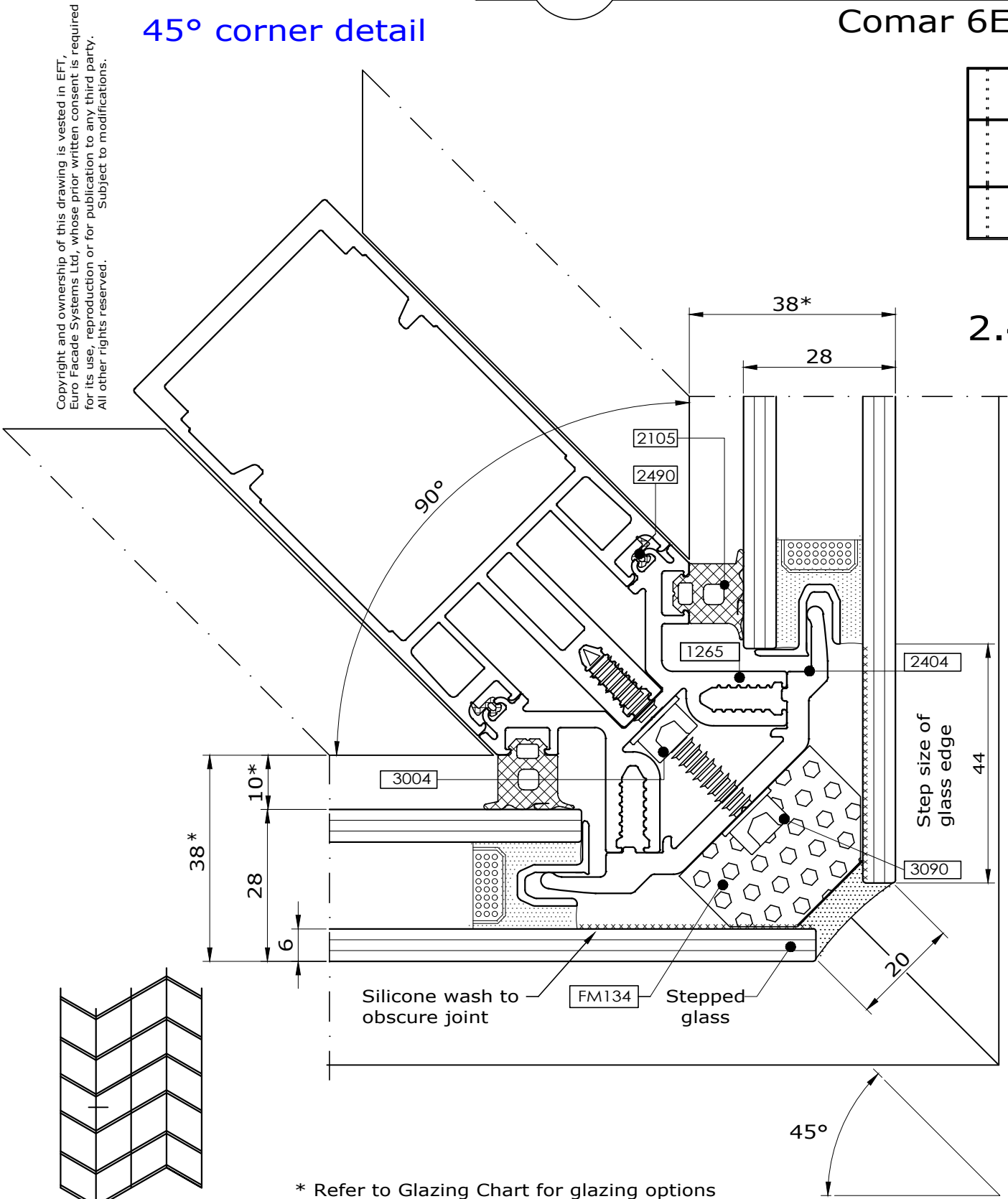

Copyright and ownership of this drawing is vested in EFT, Euro Facade Systems Ltd, whose prior written consent is required for its use, reproduction or for publication to any third party. All other rights reserved. Subject to modifications.

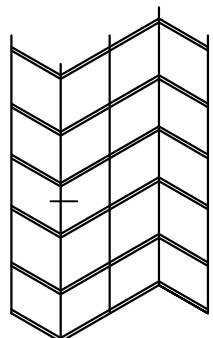

Changes reserved
 Sous reserve de modifications
 Änderungen vorbehalten

Issue: 05
 Date: 10 -16



comar
 ARCHITECTURAL ALUMINIUM SYSTEMS

Comar 6EFT

Future Additions

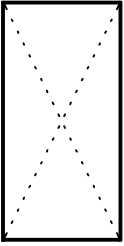

2.44

Fabricators Guide

FUTURE ADDITION

Copyright and ownership of this drawing is vested in EFT, Euro Facade Systems Ltd, whose prior written consent is required for its use, reproduction or for publication to any third party. All other rights reserved. Subject to modifications.

Copyright and ownership of this drawing is vested in EFT,
Euro Facade Systems Ltd, whose prior written consent is required
for its use, reproduction or for publication to any third party.
All other rights reserved. Subject to modifications.

Future Additions

2

Typical details

Comar 6EFT

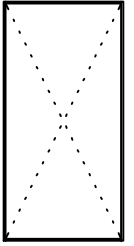

2.45

FUTURE
ADDITION

Fabrications Guide

Changes reserved
Sous reserve de modifications
Änderungen vorbehalten

Issue: 05
Date: 10 -16