

Technical Datasheet

NEW PROFILE CS627 – CLIP-ON COVER DRIP



This profile is designed to mimic the timber eye level cill of the Scola system used on the schools. It works with the Comar 2 thermally broken framework system. It can be fitted once all other works are complete.

For information on fabrication and profile limitations please contact the Comar Technical Department by e-mail at Technical@parksidegrp.co.uk or telephone 020 8685 9685

ASSOCIATED PRODUCTS
CS632 Pressure Plate,
WS004XSLF Joining Pins

| | |
|----------------------------|-------------|
| CS627 | |
| STOCK LENGTH mm | 6450 |
| QUANTITY PER CARTON | 6 |
| GROSS WEIGHT KGS. | 51 |

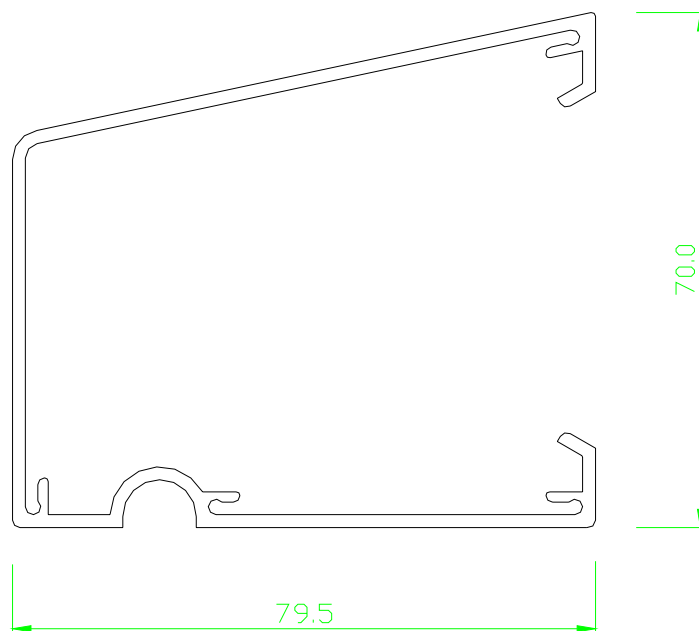

NOT TO SCALE

LIST PRICES PER UNIT LENGTH SHOWN IN £

| PROFILE REF. | MILL FINISH | NAT. SILVER ANODISED | BRZ /BLACK ANODISED | HIPCA WHITE P.P.C | RAL COLOUR P.P.C |
|--------------|-------------|----------------------|---------------------|-------------------|------------------|
| CS 627 | 72.67 | <i>101.11</i> | <i>140.15</i> | <i>97.88</i> | <i>110.42</i> |

NOTE: PRICES SHOWN IN ITALICS DENOTE FINISHES NOT ALWAYS HELD IN STOCK AND MAY BE SUBJECT TO SPECIAL PRICE AND/OR DELIVERY.



The Parkside Group Limited
Unit 5 The Willow Centre
17 Willow Lane
Mitcham Surrey CR4 4NX
Email
Technical@Parksidegrp.co.uk



| | |
|------------|----------------|
| SHEET | TD0016 |
| CHECKED BY | S.J.J. |
| DATE | 1-10-02 |