

CS351

OUTER FRAME/MULLION (SINGLE FIN)

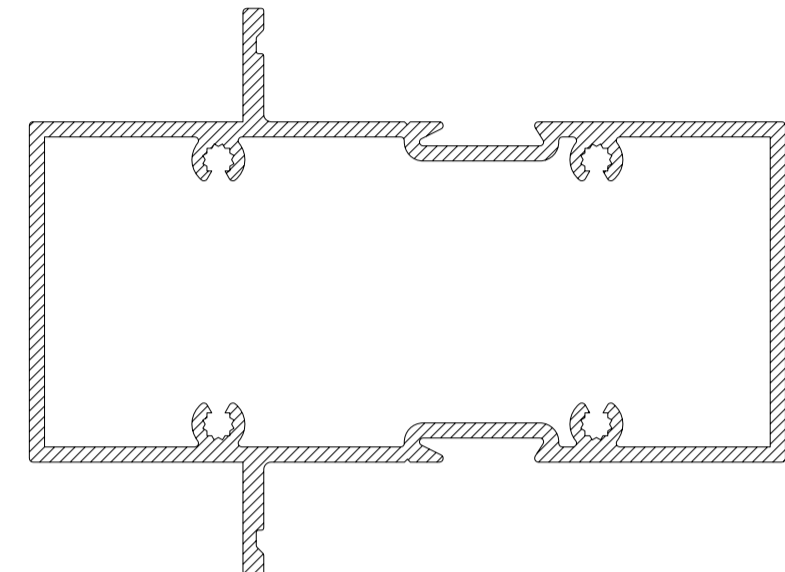

CS355

TRANSOM (DOUBLE FIN)

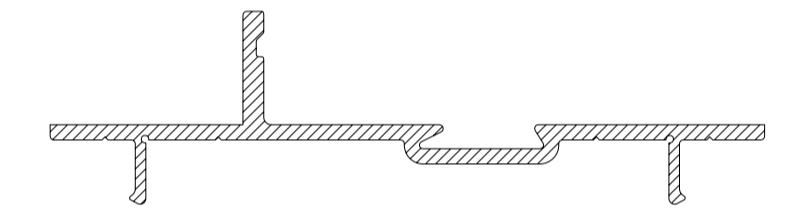

CS359

INFILL PLATE (SINGLE FIN)

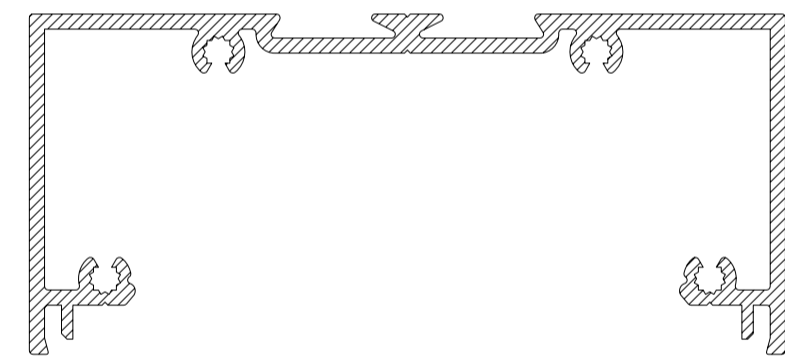

CS361

OUTER FRAME/MULLION (DOUBLE BEAD)

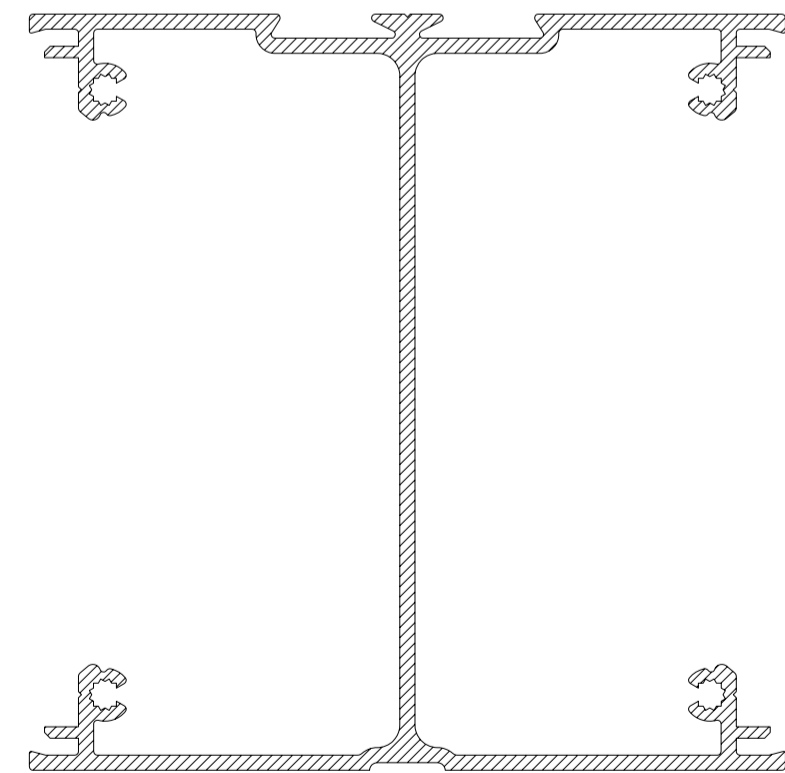

CS366

100mm x 100mm CORNER POST (DOUBLE BEAD RETURN)



CS369

INFILL PLATE (DOUBLE BEAD)

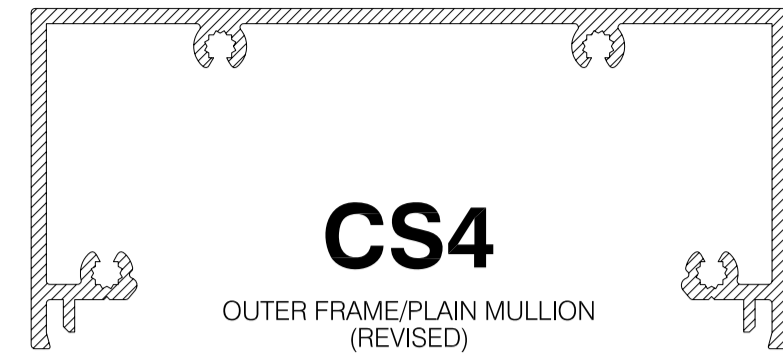

CS4

OUTER FRAME/PLAIN MULLION (REVISED)



CS12

100mm x 45mm RETURN POST

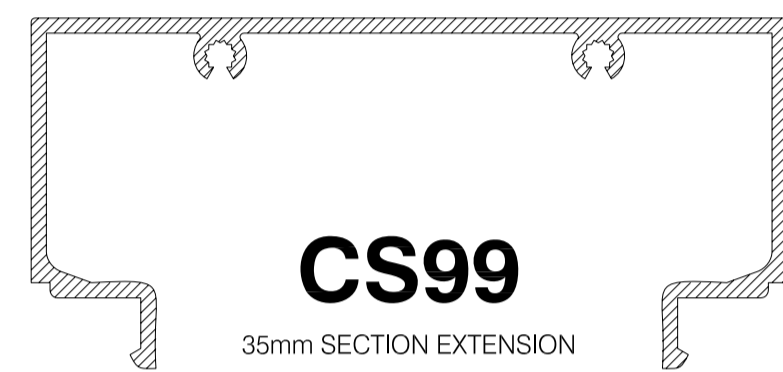

CS99

35mm SECTION EXTENSION

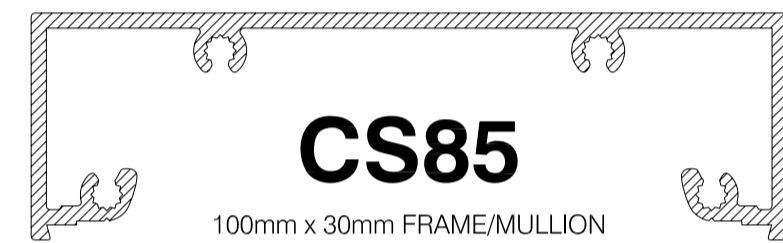

CS85

100mm x 30mm FRAME/MULLION

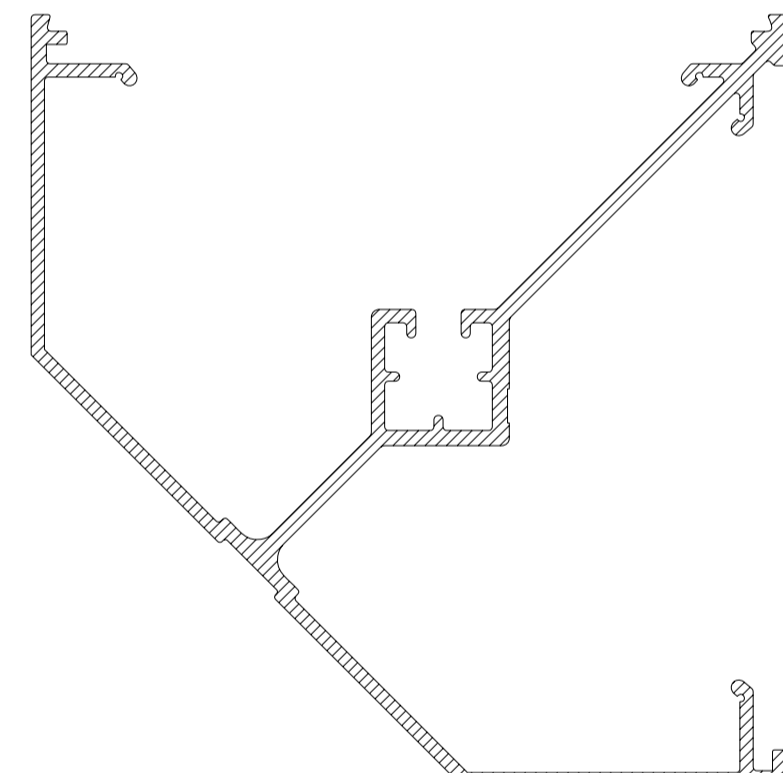

CS3

CORNER POST CANTED 90° (NOT THERMALLY BROKEN)



CS668

HEAVY DUTY ALTERNATIVE TO CS8
INFILL PLATE - PLAIN



CS8

INFILL PLATE - PLAIN

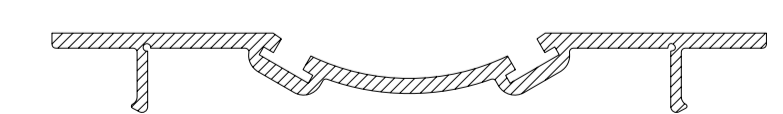

CS90

FINGER GUARD INSERT

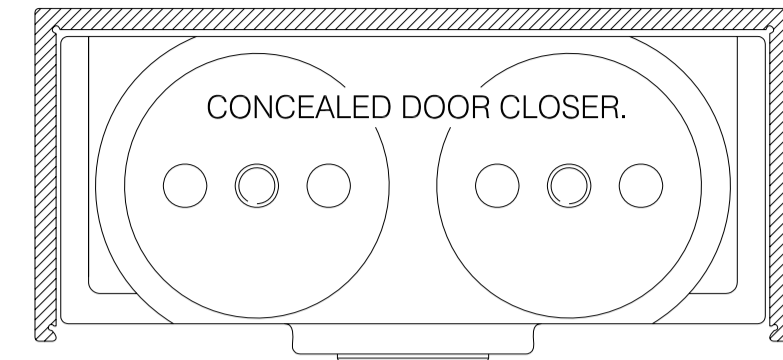

CS13

100mm x 45mm HEADER BAR

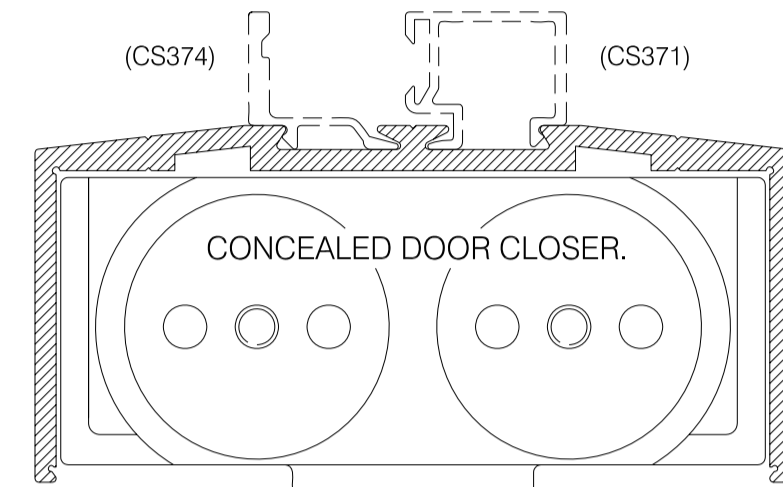

CS163

HEADER BAR (GLAZING ABOVE)

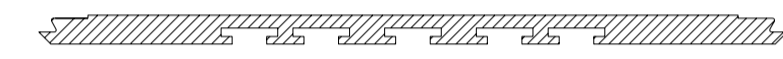

CS68

UNIVERSAL HEADER BAR PLATE

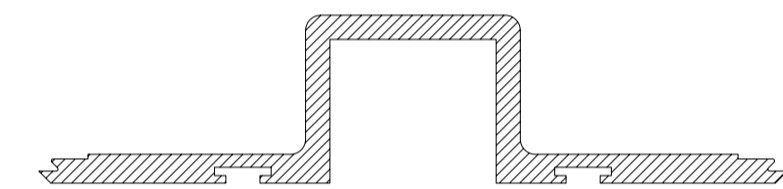

CS42

HEADER BAR PLATE (SLIDING/FOLDING DOORS)

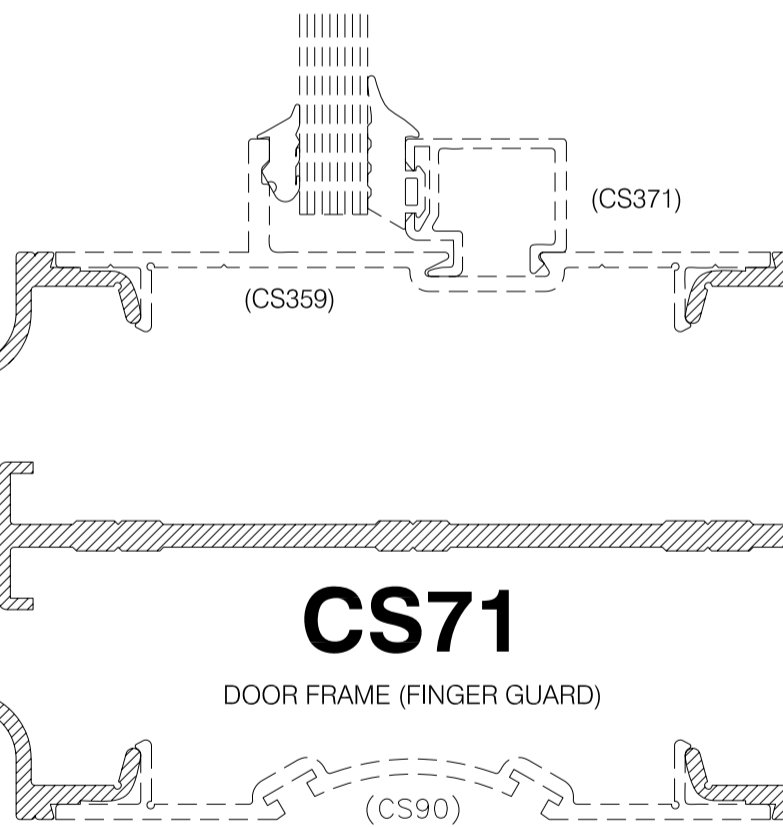

CS71

DOOR FRAME (FINGER GUARD)

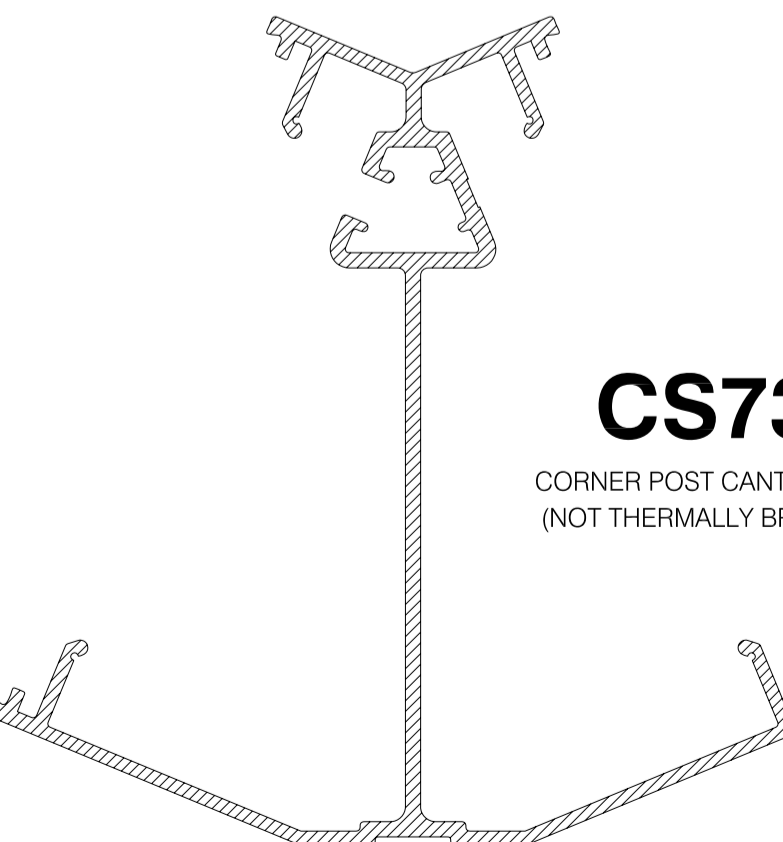

CS73

CORNER POST CANTED 135° (NOT THERMALLY BROKEN)

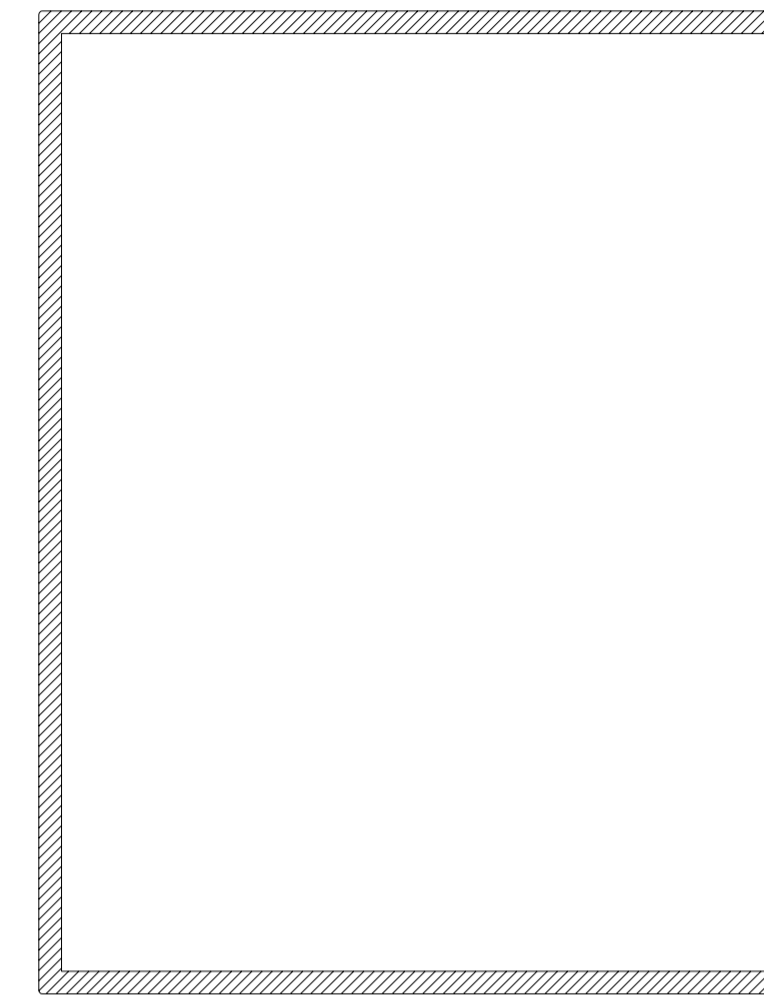

CS208

100mm x 130mm BOX/PORTAL/JAMB

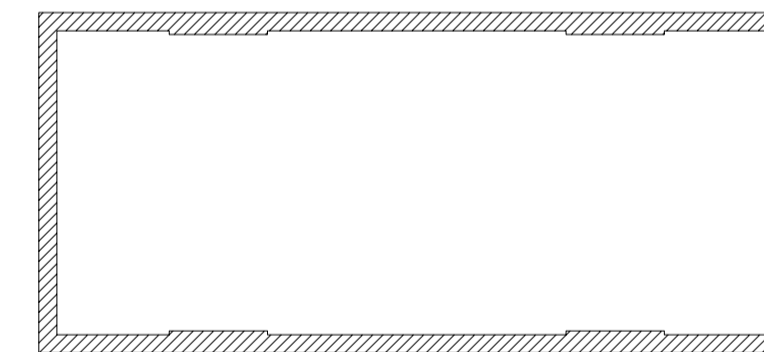

CS49

100mm x 45mm STD. BOX

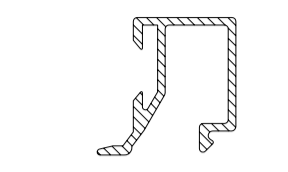

CS26

GLAZING BEAD (SINGLE/DOUBLE GLAZE)

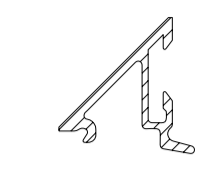

CS27

GLAZING BEAD (ANGLED)

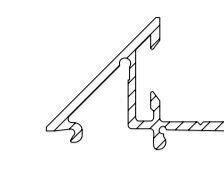

CS29

SECURITY BEAD (ANGLED)

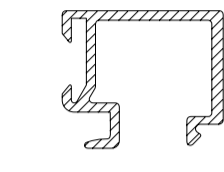

CS371

GLAZING BEAD (SINGLE GLAZE)

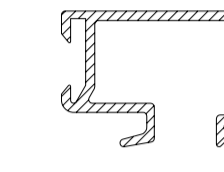

CS372

GLAZING BEAD (SINGLE GLAZE)

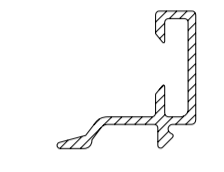

CS373

GLAZING BEAD (DOUBLE GLAZE)

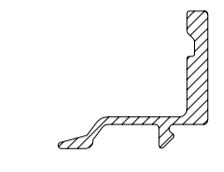

CS374

GLAZING BEAD (DOUBLE GLAZE)

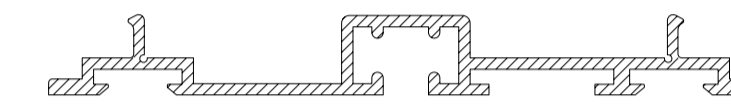

CS308

JAMB FIXING BACK PLATE



CS666

INFILL PLATE

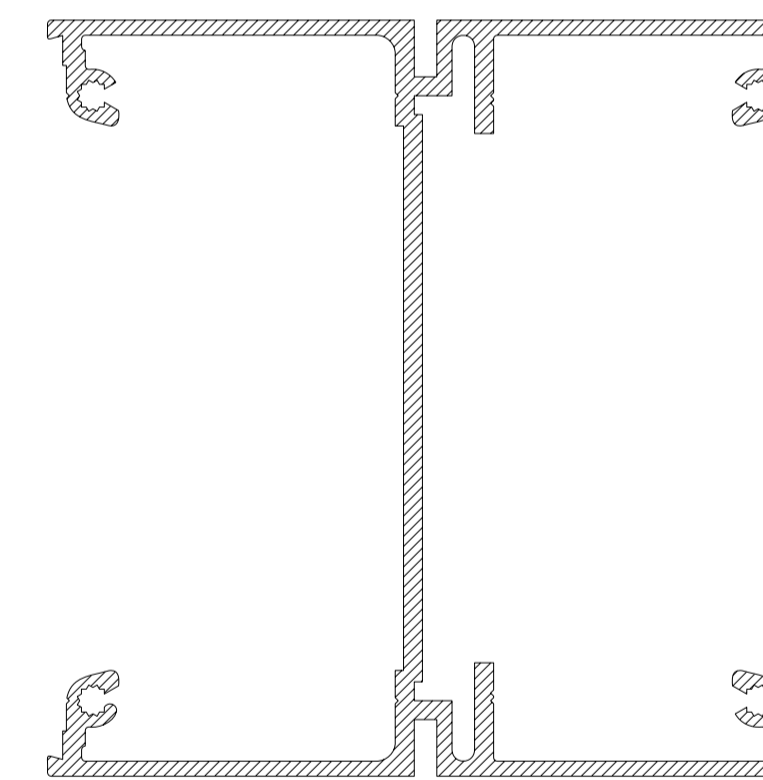

CS206

100mm x 100mm FRAME/MULLION

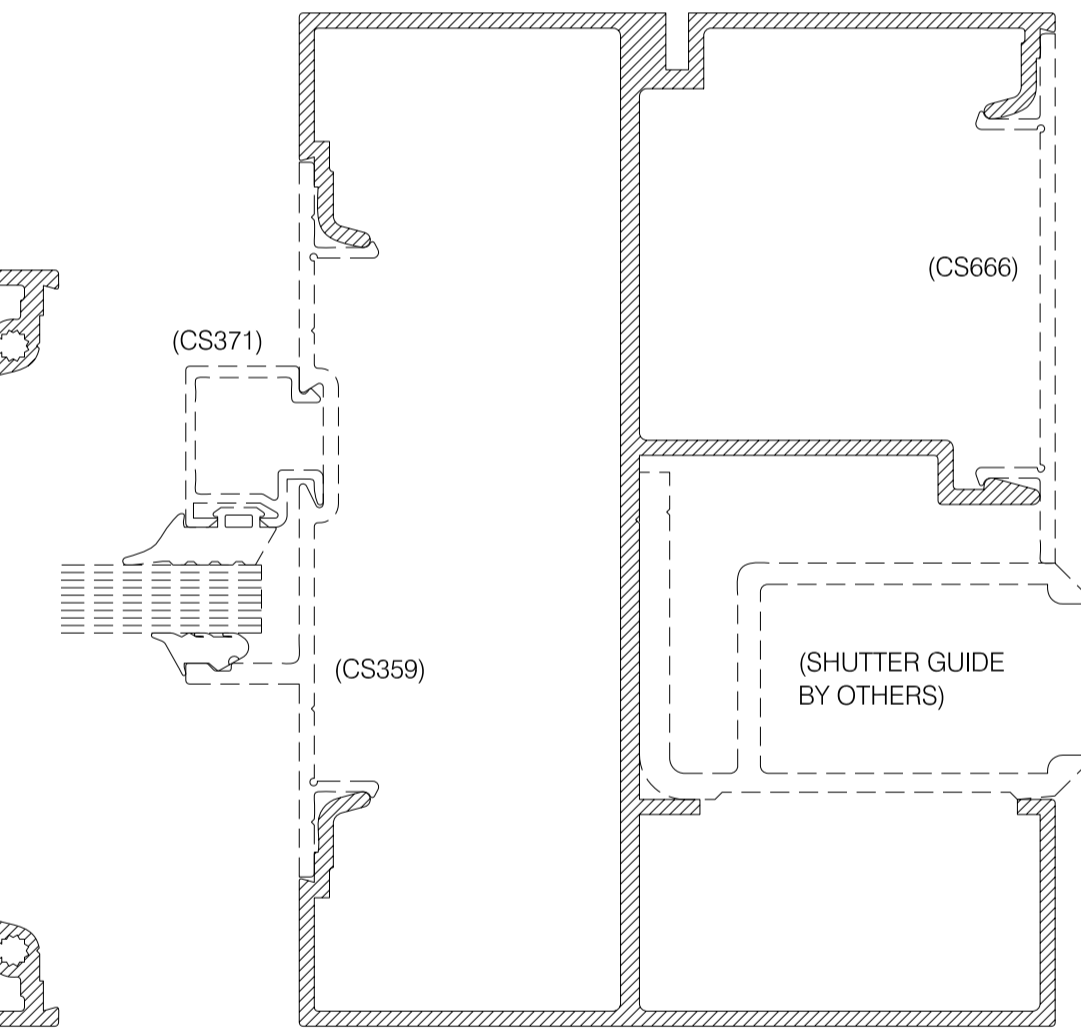

CS207

100mm x 134mm FRAME/MULLION



GK22

2mm INSERT
COLOUR CODE WHITE



GK23

3mm INSERT
COLOUR CODE YELLOW



GK24

4mm INSERT
COLOUR CODE BLUE

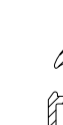

GK25

5mm INSERT
COLOUR CODE RED

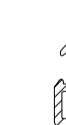

GK26

6mm INSERT
COLOUR CODE GREEN



GK32

2mm WEDGE
COLOUR CODE WHITE



GK33

3mm WEDGE
COLOUR CODE YELLOW



GK34

4mm WEDGE
COLOUR CODE BLUE



GK35

5mm WEDGE
COLOUR CODE RED



GK36

6mm WEDGE
COLOUR CODE GREEN

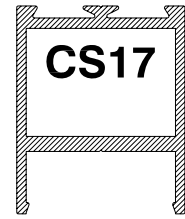

CS17

55mm DOOR/SASH RAIL

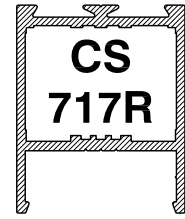

CS717R

75mm DOOR/SASH RAIL REVISED (ECONOMY)

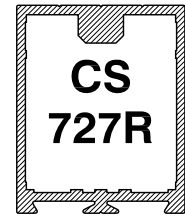

CS727R

55mm DOOR/SASH RAIL REVISED (ECONOMY)

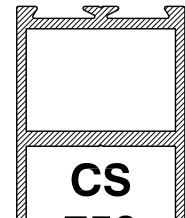

CS750

75mm DOOR/SASH RAIL

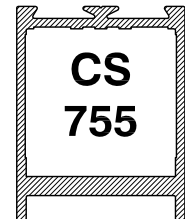

CS755

75mm DOOR/SASH RAIL

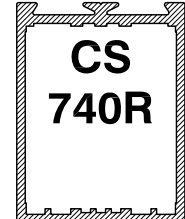

CS740R

75mm DOOR/SASH RAIL (REVISED)



CS721

10mm DOUBLE SIDED RAIL/BEAD CARRIER



CS21

10mm BEAD CARRIER

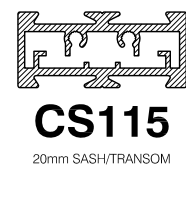

CS115

20mm SASH/TRANSOM

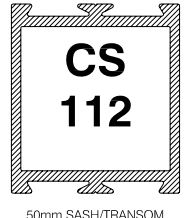

CS112

50mm SASH/TRANSOM

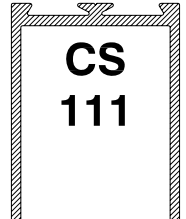

CS111

100mm SASH/TRANSOM

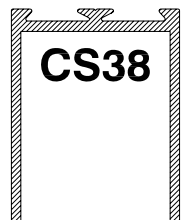

CS38

150mm SASH/TRANSOM

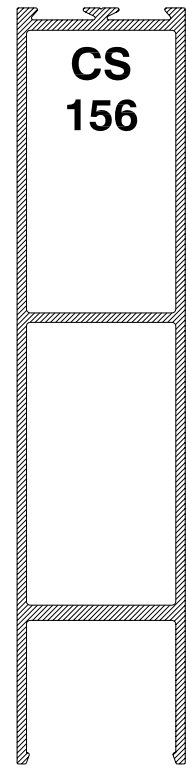

CS156

200mm SASH RAIL

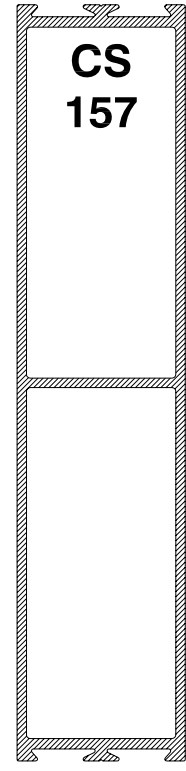

CS157

200mm SASH/TRANSOM

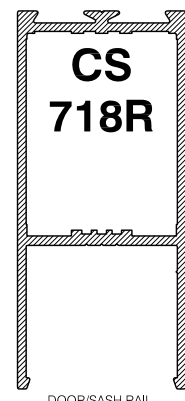

CS718R

DOOR/SASH RAIL REVISED (ECONOMY)

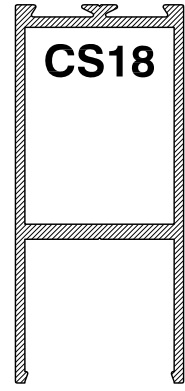

CS18

100mm SASH RAIL

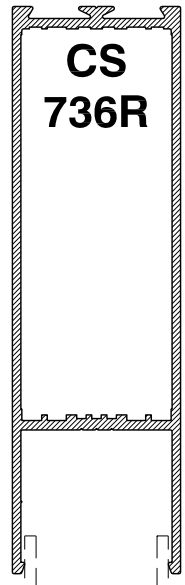

CS736R

150mm DOOR/SASH RAIL (REVISED)

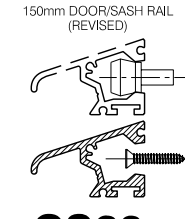

CS83

DRIP SECTION
FX046SLF STUD & FX045SLF FIXING,
FX047SLF PROFILE RIVET



CS30

SCREW OR CLIP BEAD /DRAUGHT STRIP
FX046SLF STUD & FX045SLF FIXING,
FX047SLF PROFILE RIVET

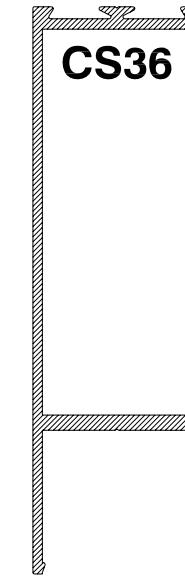

CS36

150mm SASH RAIL

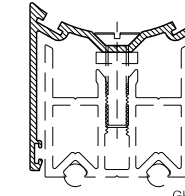

CS790

ADJUSTABLE FINGER GUARD

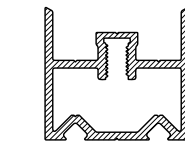

CS791

ADJUSTABLE FINGER GUARD
FIXING CHANNEL
(NEW DESIGN)



CS583

DRIP SECTION
FX048SLF (RIVET)

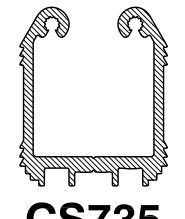

CS735

DOOR / SASH, SCREW /
TIE-ROD CLEAT
(BAR LENGTH ONLY
AVAILABLE)

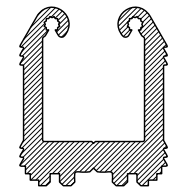

CS35R

DOOR / SASH SCREW CLEAT - DOOR
(BAR LENGTH ONLY
AVAILABLE)

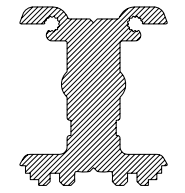

CS34

DOOR/SASH, WELDING/
SCREW CLEAT



CS191

38 x 25mm x 4 MTS CHANNEL

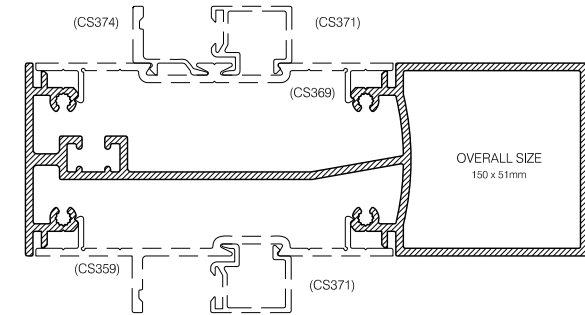

CS178

HIGH SPAN MULLION
(NOT THERMALLY BROKEN)

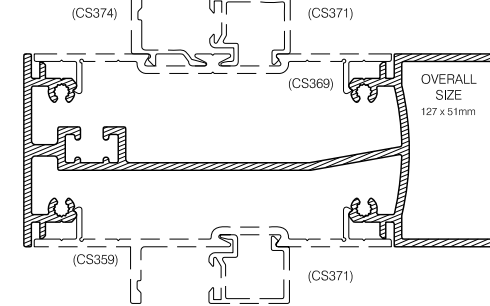

CS148

HIGH SPAN MULLION
(NOT THERMALLY BROKEN)

CS585

FRAMEWORK SUB SILL (T.B)

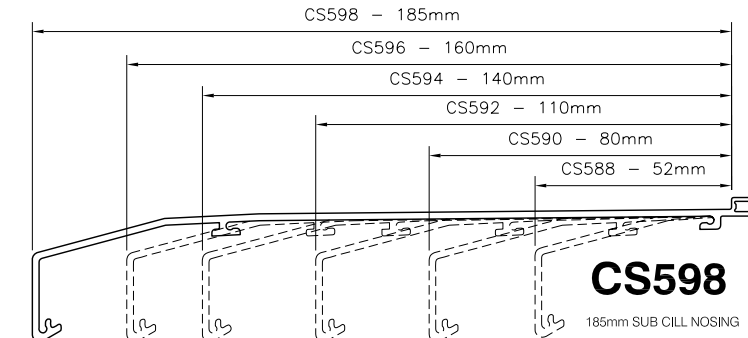

CS598

185mm SUB CILL NOSING

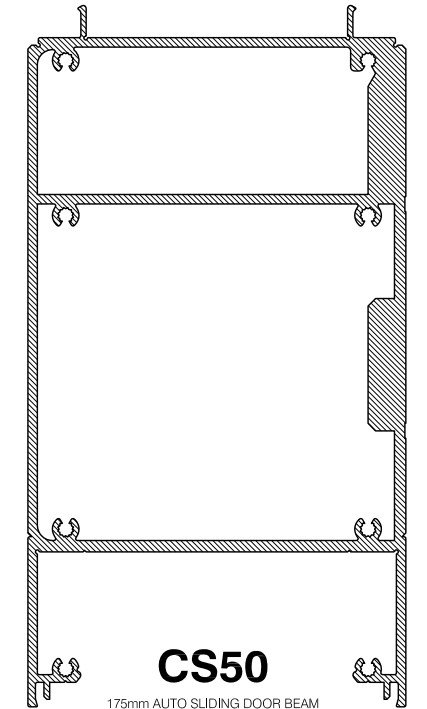

CS50

175mm AUTO SLIDING DOOR BEAM

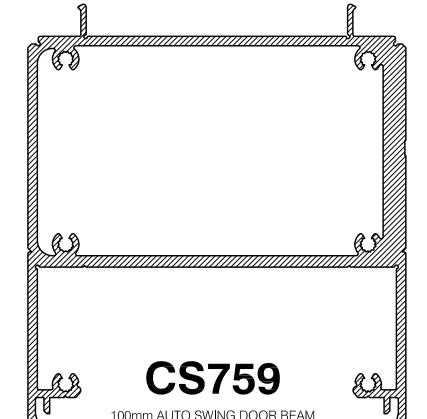

CS759

100mm AUTO SWING DOOR BEAM



CS744

45mm AUTO SLIDING/DOOR SWING
DOOR BEAM EXTENSION

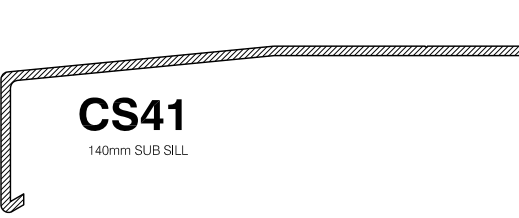

CS41

140mm SUB SILL

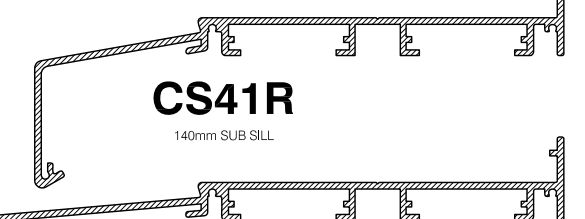

CS41R

140mm SUB SILL

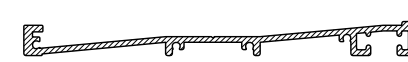

CS72

DRAINAGE TRAY
(NOT THERMALLY BROKEN)



CS95

200mm SUB SILL