

1. Position PN track as shown, 5.5mm from rebate and fix with No.8 CSK screws.

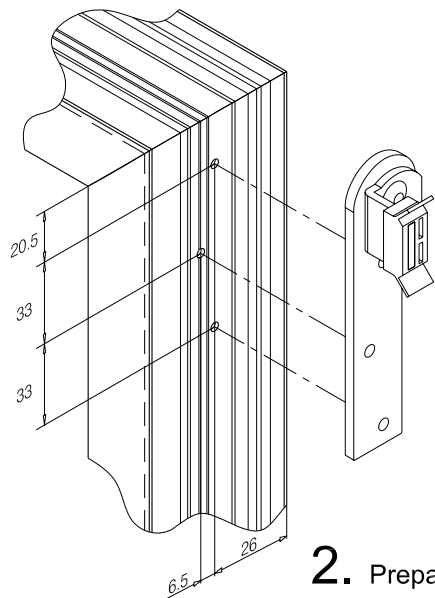

2. Preparing top corners of sash to receive Top glider PN No. 3875.

Outer frame and vent shown from the inside to illustrate fitting of window hardware.

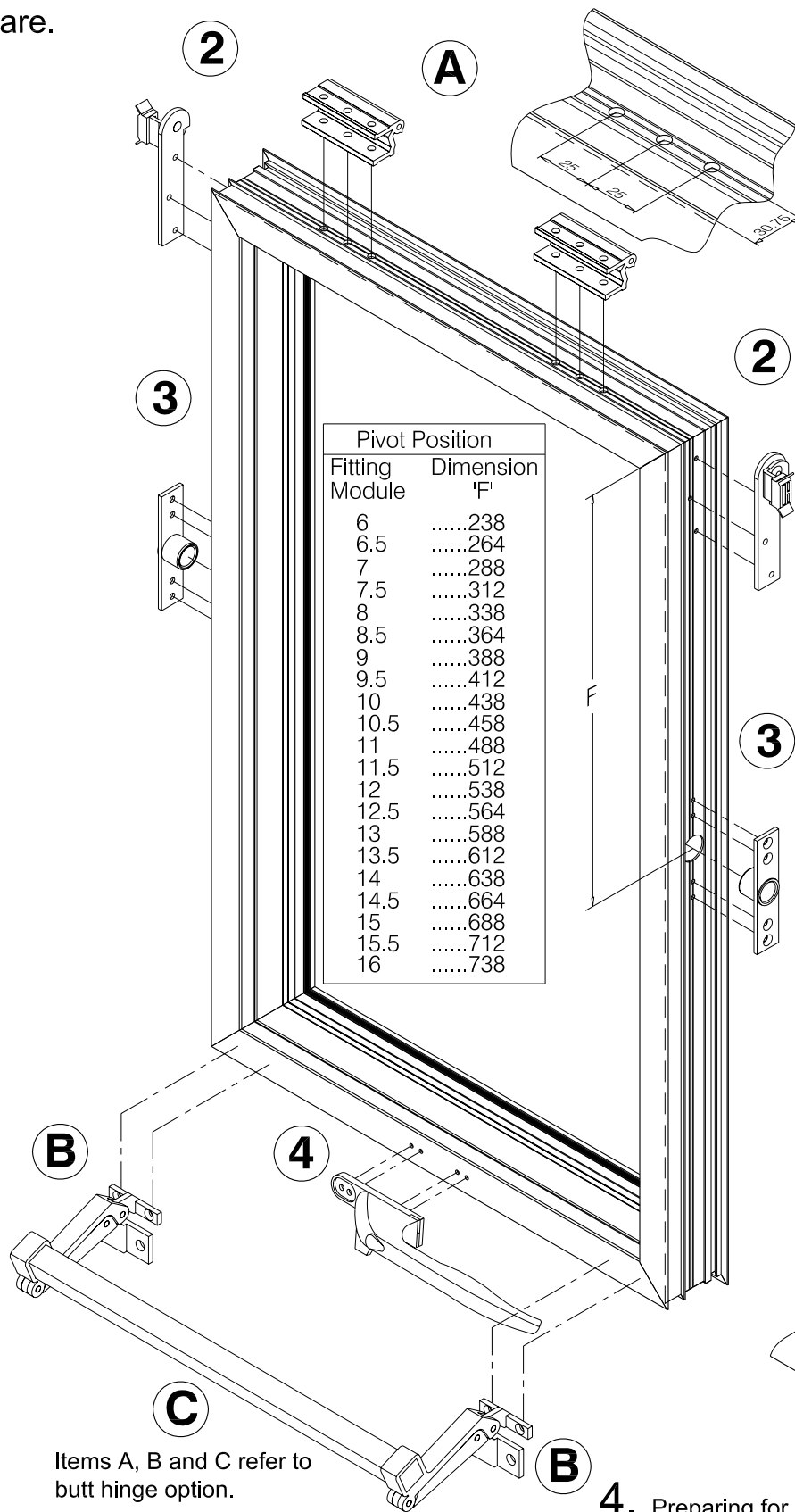
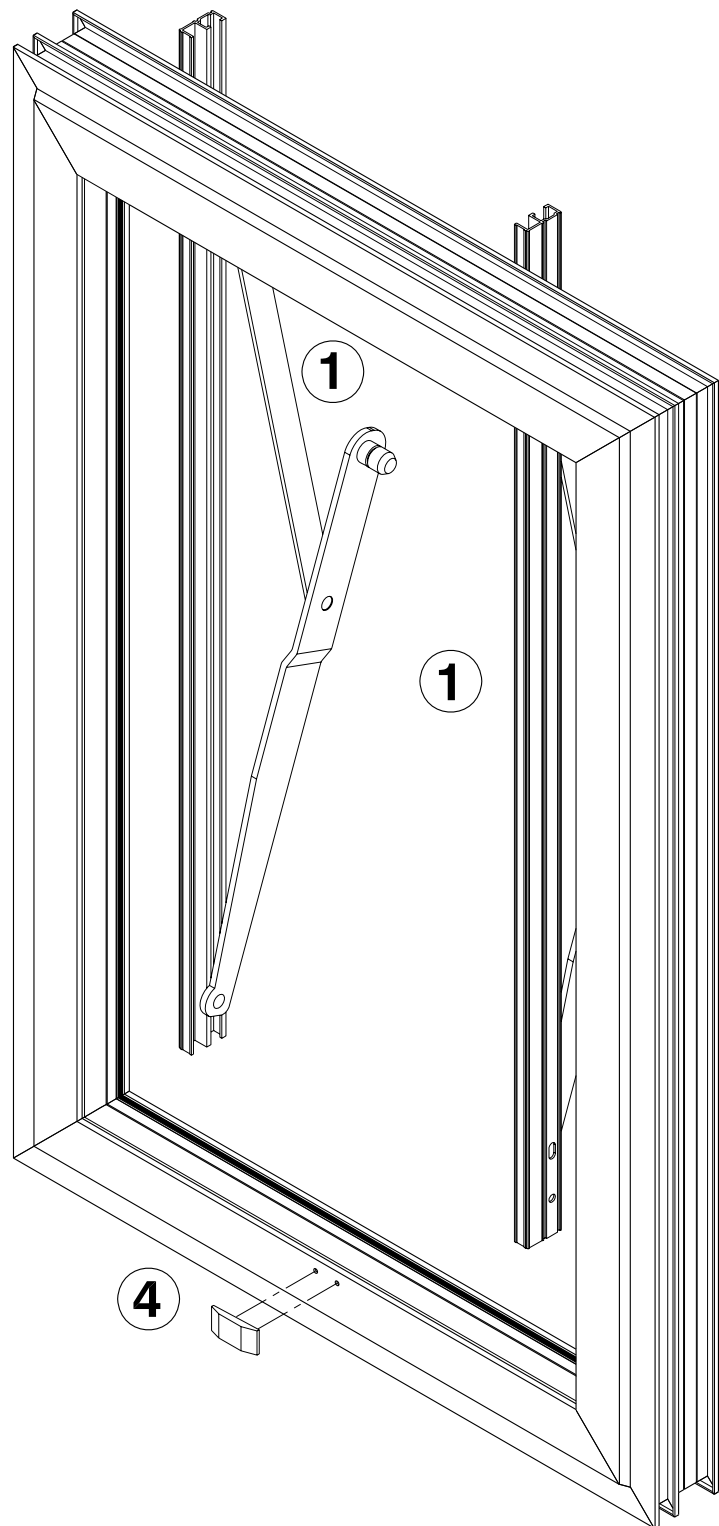

Items A, B and C refer to butt hinge option.

3. Preparing sash to receive PN pivot bracket.
Tooling Ref: COM5 T15

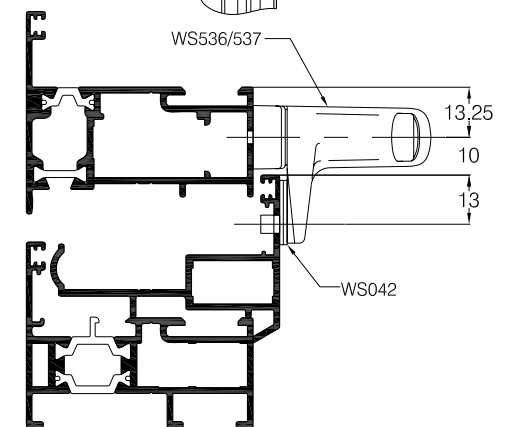
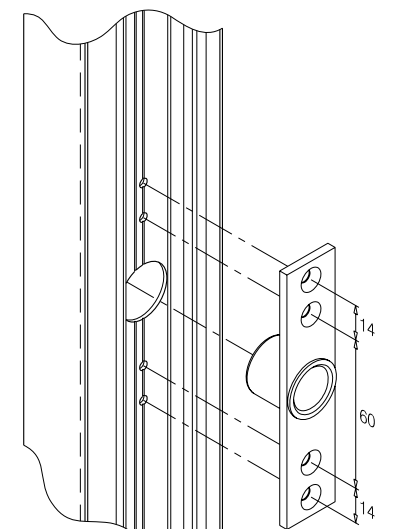

4. Preparing for Comar handle ref: WS536 (LH); WS537 (RH) and wedge WS042.

