

CS416

60mm CORNER POST

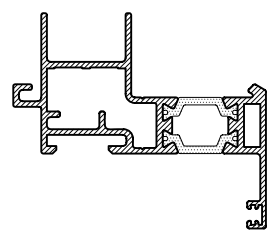

CS413

OPEN OUT VENT CURTAIN WALL WINDOW INSERT

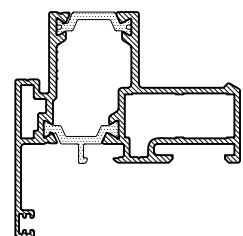

CS412

TILT&TURN / PIVOT CURTAIN WALL WINDOW INSERT

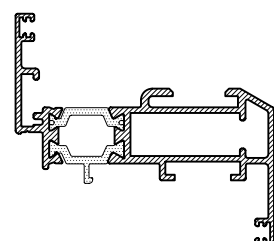

CS433

TILT & TURN SASH

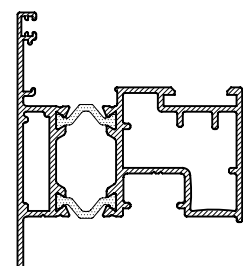

CS411

SECURITY RATED CASEMENT VENT



CS215

WINDOW DRIP



CS583

WINDOW DRIP FX048SLF (RIVET)

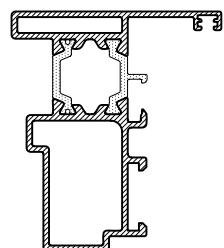

CS440

FRENCH CASEMENT TRANSFER MULLION

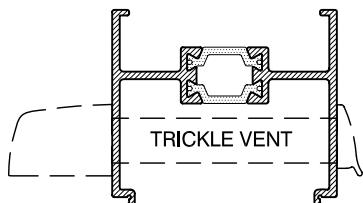

CS451

60mm OUTER FRAME EXTENSION

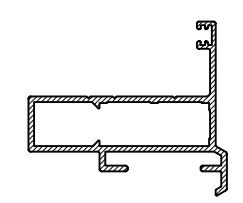

CS463

60mm WINDOW TRANSFER

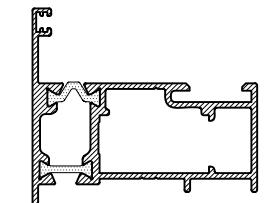

CS438

TOP SWING OR CASEMENT VENT

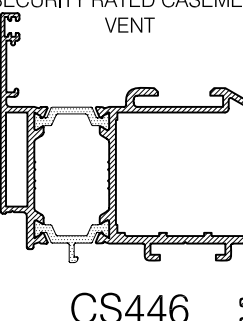

CS446

HEAVY DUTY TILT & TURN SASH

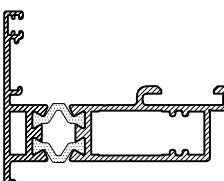

CS453

FIXED LIGHT TRANSFER PROFILE

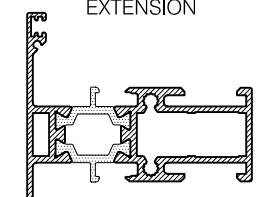

CS435

TRANSOM, MULLION OR SASH

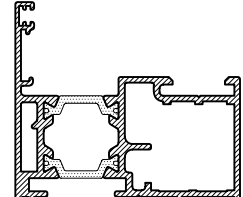

CS425

TOP/SIDE PROJECTED CASEMENT VENT

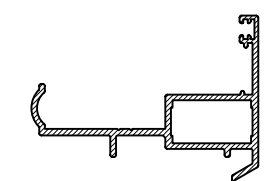

CS437

TOP SWING TRANSFER PROFILE

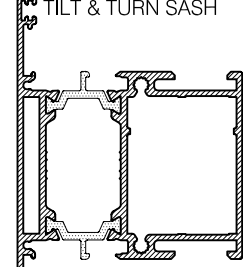

CS421

HEAVY DUTY INTERNAL BEAD TRANSOM

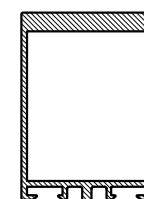

CS223

120mm COUPLING MULLION

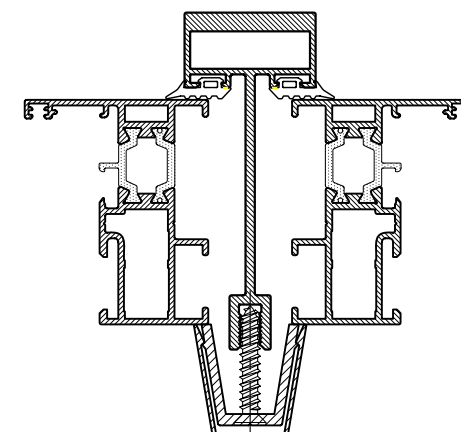

CS222

90mm COUPLING MULLION

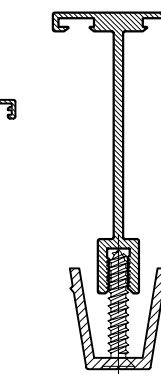

CS221

75mm COUPLING MULLION

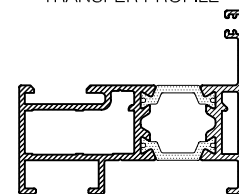

CS434

FIXED LIGHT OR OUTER FRAME

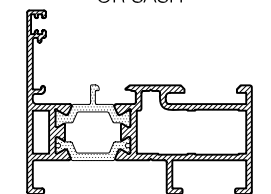

CS431

FIXED LIGHT OR OUTER FRAME

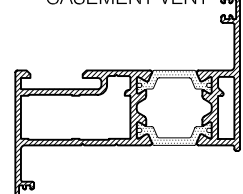

CS436

OPEN OUT SASH OR ODD LEG OUTER FRAME

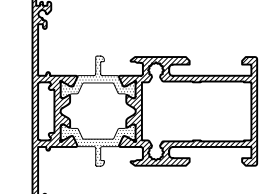

CS432

PIVOT VENT / MULLION OR TRANSOM

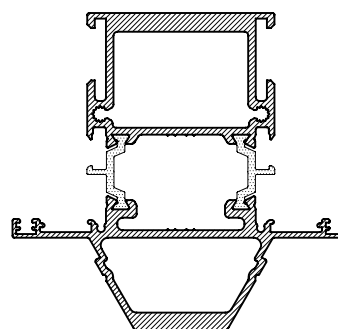

CS419

HEAVY DUTY INTERNAL BEAD MULLION

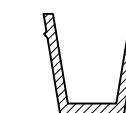

CS524

MULLION CLAMP

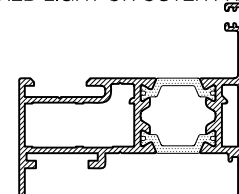

CS410

LONG LEG FIXED LIGHT OR OUTER FRAME

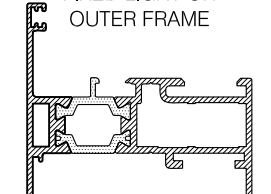

CS409

LONG LEG FIXED LIGHT OR OUTER FRAME

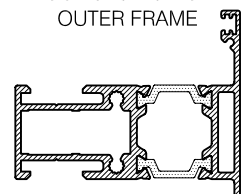

CS439

TRANSOM OR MULLION

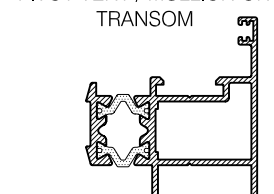

CS420

PIVOT TRANSFER

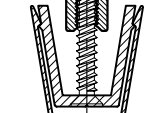

CS223

120mm COUPLING MULLION

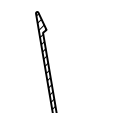

CS525

MULLION CLAMP COVER



CS416

60mm CORNER POST



CS413

OPEN OUT VENT CURTAIN WALL WINDOW INSERT

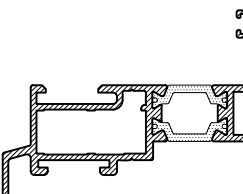

CS412

TILT&TURN / PIVOT CURTAIN WALL WINDOW INSERT

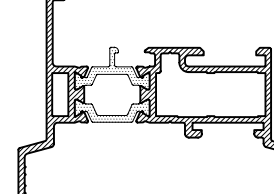

CS433

TILT & TURN SASH

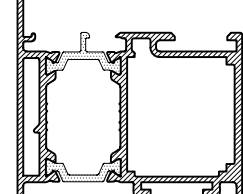

CS411

SECURITY RATED CASEMENT VENT



CS440

FRENCH CASEMENT TRANSFER MULLION

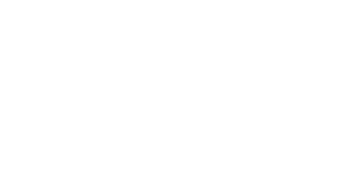

CS451

60mm OUTER FRAME EXTENSION



CS463

60mm WINDOW TRANSFER



CS438

TOP SWING OR CASEMENT VENT

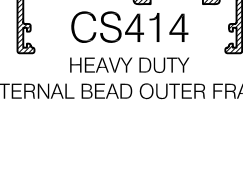

CS446

HEAVY DUTY TILT & TURN SASH



CS453

FIXED LIGHT TRANSFER PROFILE



CS435

TRANSOM, MULLION OR SASH

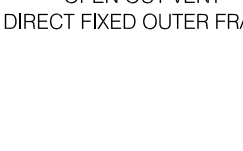

CS425

TOP/SIDE PROJECTED CASEMENT VENT

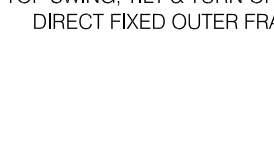

CS437

TOP SWING TRANSFER PROFILE

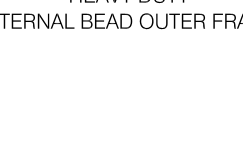

CS421

HEAVY DUTY INTERNAL BEAD TRANSOM

CS434

FIXED LIGHT OR OUTER FRAME

CS431

FIXED LIGHT OR OUTER FRAME

CS436

OPEN OUT SASH OR ODD LEG OUTER FRAME

CS432

PIVOT VENT / MULLION OR TRANSOM

CS419

HEAVY DUTY INTERNAL BEAD MULLION

CS410

LONG LEG FIXED LIGHT OR OUTER FRAME

CS409

LONG LEG FIXED LIGHT OR OUTER FRAME

CS439

TRANSOM OR MULLION

CS420

PIVOT TRANSFER

CS434

FIXED LIGHT OR OUTER FRAME

CS431

FIXED LIGHT OR OUTER FRAME

CS436

OPEN OUT SASH OR ODD LEG OUTER FRAME

CS432

PIVOT VENT / MULLION OR TRANSOM

CS419

HEAVY DUTY INTERNAL BEAD MULLION

CS410

LONG LEG FIXED LIGHT OR OUTER FRAME

CS409

LONG LEG FIXED LIGHT OR OUTER FRAME

CS439

TRANSOM OR MULLION

CS420

PIVOT TRANSFER

CS419

HEAVY DUTY INTERNAL BEAD MULLION



GK54
EURO GROOVE FILLER



GK23
3mm GLAZING
INSERT (YELLOW)



GK401
2mm GLAZING
WEDGE (GREY)



GK40
TILT & TURN CENTRE
SEAL

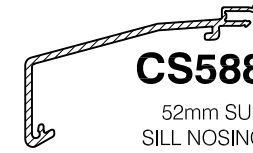

CS588
52mm SUB
SILL NOSING

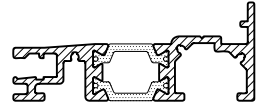

CS484
WINDOW SUB SILL (T.B)



GK35
5mm GLAZING
WEDGE (RED)



GK403
3mm GLAZING
WEDGE (WHITE)



GK41
PIVOT CENTRE
SEAL

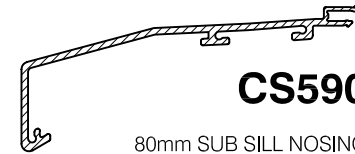

CS590
80mm SUB SILL NOSING

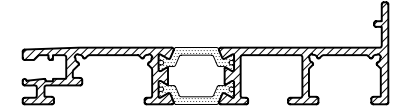

CS485
FRAMEWORK SUB SILL (T.B)

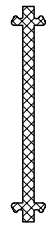

GK67
DIRECT COUPLING LOCATOR



GK422
2mm ARROW
HEAD GASKET



GK405
4mm GLAZING
WEDGE (GREEN)



GK48
PIVOT EXTERNAL
SEAL

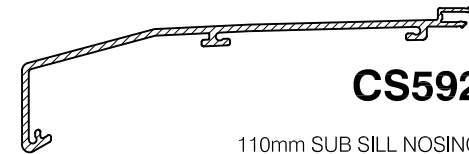

CS592
110mm SUB SILL NOSING

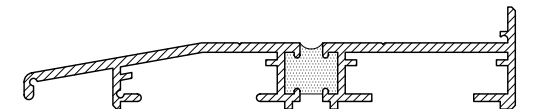

CS132
130mm SILL TRAY (T.B)

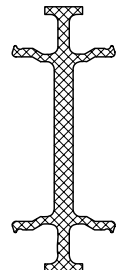

GK60
DIRECT FIXED WINDOW
COUPLING LOCATOR



GK425
5mm ARROW
HEAD GASKET



GK407
5mm GLAZING
WEDGE (BROWN)



GK49
TOP SWING
OUTER SEAL

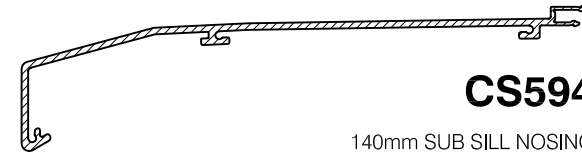

CS594
140mm SUB SILL NOSING

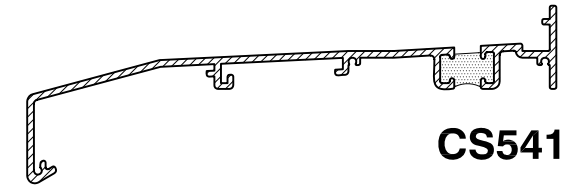

CS541
140mm SUB SILL (T.B)



GK441
COMPRESSION
WEATHER STRIP



GK408
6mm WEDGE
INSERT (PINK)

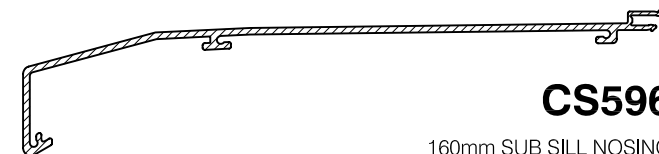

CS596
160mm SUB SILL NOSING

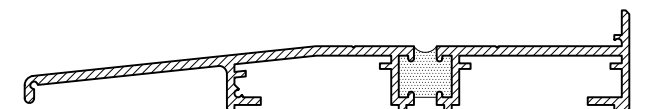

CS151
160mm SUB SILL TRAY (T.B)

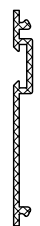

GK69
60mm CAVITY CLOSER

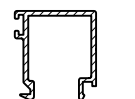

CS423
GLAZING BEAD
22mm - 27mm

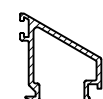

CS424
GLAZING BEAD
22mm - 27mm

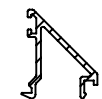

CS422
SLOPED GLAZING BEAD
28mm

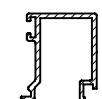

CS429
GLAZING BEAD
25mm - 30mm

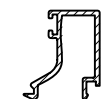

CS428
GLAZING BEAD
30mm - 35mm

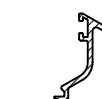

CS430
GLAZING BEAD
30mm - 35mm

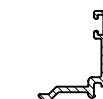

CS427
GLAZING BEAD
40mm - 45mm

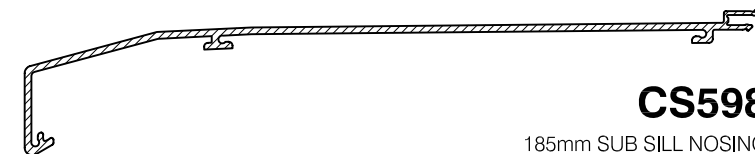

CS598
185mm SUB SILL NOSING

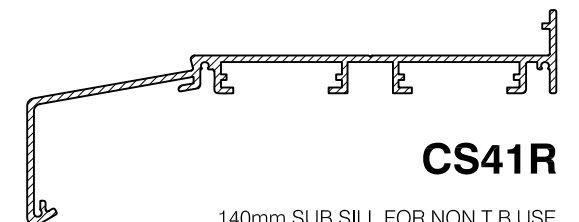

CS41R
140mm SUB SILL FOR NON T.B USE

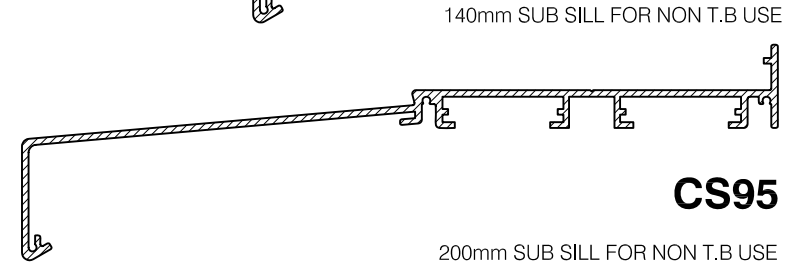

CS95
200mm SUB SILL FOR NON T.B USE

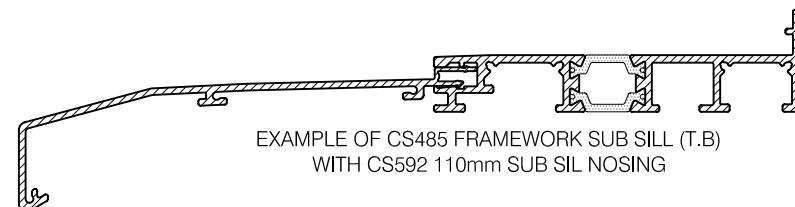

EXAMPLE OF CS485 FRAMEWORK SUB SILL (T.B)
WITH CS592 110mm SUB SIL NOSING

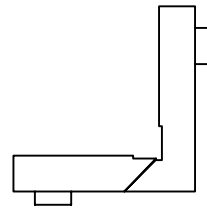
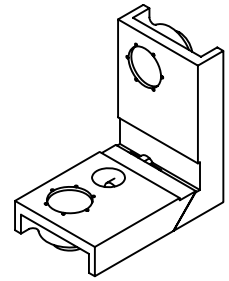

WS380XSLF
SPRUNG LOADED
CLEAT

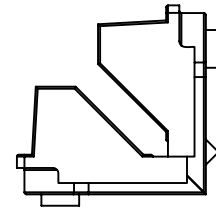
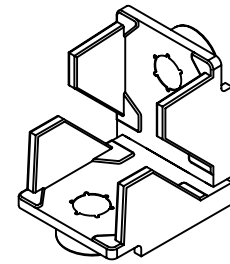

WS449XSLF
SPRUNG LOADED
CLEAT

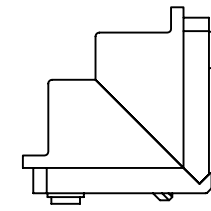
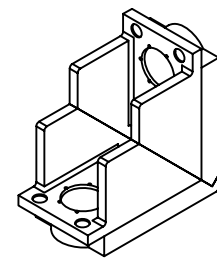

WS668XSLF
SPRUNG LOADED
CLEAT

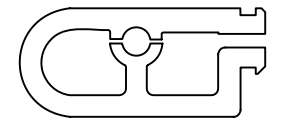
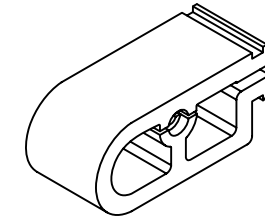

WS570XSLF
TRANSOM/MID RAIL CLEAT

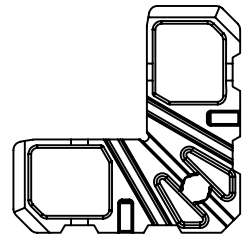
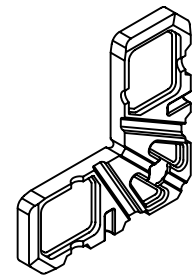

WS182XSLF
PINNED CLEAT

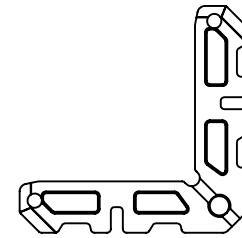
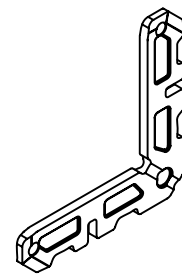

WS189XSLF
PINNED CLEAT



WS515
CHEVRON

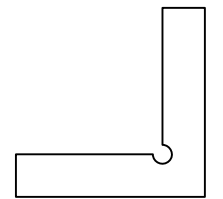
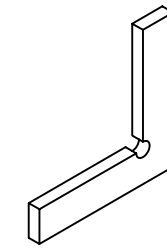

WS415XSLF
11.5mm PLASTIC CHEVRON

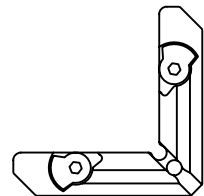
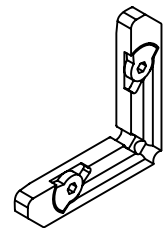

WS416XSLF
ALIGNMENT SQUARE

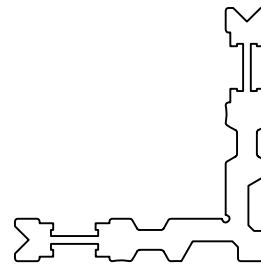
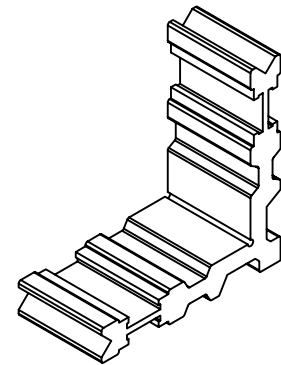

CS246
11mm WINDOW CLEAT

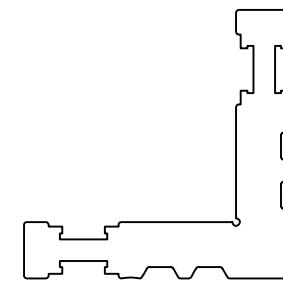
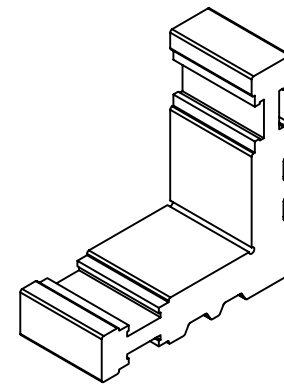

CS247
15mm WINDOW CLEAT

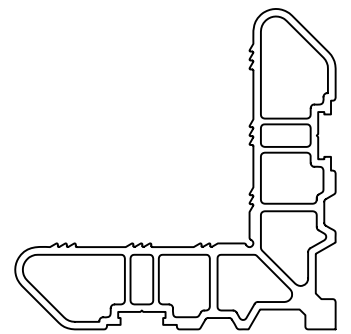
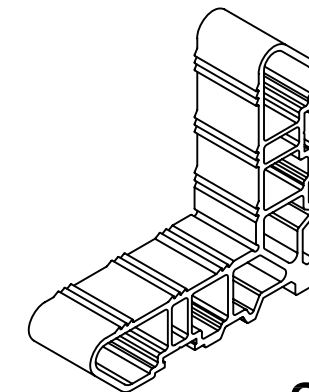

CS547
23mm WINDOW CLEAT